

Our company, which has been operating in the grounding and lightning protection sector since 1953, is the market leader thanks to its many years of experience, design and R&D expertise, strong production infrastructure, domestic/international application capabilities, customer satisfaction-oriented sales activities, and after-sales support capabilities.

### Innovation and Quality

- ✓ 1953 Founded
- ✓ 1962 FIRST Production Facility
- ✓ 1974 FIRST Radioactive Lightning Rod Production in Turkey
- ✓ 1987 Cable Boot Production
- ✓ 1998 Commissioning of the Integrated Production Facility [26,000 m<sup>2</sup> area with 7,200 m<sup>2</sup> of covered space]
- ✓ 2002 First Active Lightning Rod Production in Turkey
- ✓ 2008 Implementation of ERP System
- ✓ 2011 Integrated Quality Management System (ISO 9001, ISO 14001, ISO 18001)
- ✓ 2013 First member from Turkey accepted into ILPA (International Lightning Protection Association)
- ✓ 2014 First and only Lightning Detection and Warning Network established in Turkey
- ✓ 2015 Commissioning of the Grounding Strip Production Line
- ✓ 2015 Opening of the Marmara Regional Directorate
- ✓ 2017 Thermoweld Production
- ✓ 2018 Opening of the Aegean Regional Directorate
- ✓ 2020 FIRST and ONLY A.G. Surge Protector Production in Turkey
- ✓ 2021 Opening of the Gaziantep Regional Directorate

HASANOĞLAN FACTORY



İSTANBUL BRANCH



İZMİR BRANCH



GAZİANTEP BRANCH



RADSAN CENTER

# CONTENTS

## LIGHTNING PROTECTION

Need of Protection and Radsan Protection Concept	4 - 7
Aircraft Warning Lamps	8 - 10
Lightning and Lightning Protection Basics	11
Ese Lightning Arresters	12 - 15
Testers and Counters	16
Smart Coding	17
Application Examples	18 - 22
ESE Lightning Arrester Installation Equipments	23 - 25
ESE Lightning Arrester Installation Equipments	26 - 34
Mesh Method and Installation Equipments	35 - 47
Stretch Wire Method	48 - 51
Down Conductors	52
Down Conductor Installation Equipments	53 - 80

## A.G. SURGE ARRESTER SERIES

A.G. Parafudr	81 - 86
Technical Principles	87 - 102
T1+2 Class	103 - 127
T1 Class	128 - 139
T2 Class	140 - 147
T2+3 Class	148 - 153
T3 Class	154 - 155
DC Class	156 - 161
PV Class	162 - 169
Data SPDs	170 - 175

## EARTHING

Smart Coding	179
Conductor Specs	180
Conductors Hot Dip Galvanized Steel Conductors Copper Conductors	181 - 188
Clemens	189 - 201
Electrodes Hot Dip Galvanized Steel Electrodes Copper Electrodes Earthing Plates	202 - 211
Earthing Rod Connectors	212 - 211
Rem	212 - 214
Earthing Points	215 - 217
Bars	218 - 222
Earthing Drums	223
Static Earthing Pit	224
Earthing Pit	225
Earthing Measurement Devices	226
CADWELD	227 - 236

## CABLE LUGS

Secure Connection - Secure Service	239
SKP Cable Lugs DIN 46235 Series Standard Series Standard Long Series Economical Series Aluminum Series Bimetal Series	240 - 246
Butt Connectors DIN Series TSE Series Ekonomik Series	247
Compression Tips	248

# LIGHTNING PROTECTION



# LIGHTNING

## HOW IS LIGHTNING FORMED?



Under normal conditions, there is a charge balance between the earth and the atmosphere. The formation of storm clouds disrupts this balance, causing polarization. Lightning and thunder occur when the disrupted charge balance is restored.

Ninety percent of lightning strikes are negative lightning strikes from the cloud to the ground. In this type of lightning, the lower regions of the cloud have a negative charge. This charge charges the earth and objects on it with a positive charge. The positive charge on the earth is more concentrated in metal objects, pointed objects, and well-grounded objects.

The required electric field strength for lightning to form is 0.5-10 kV/cm. When the electric field increases sufficiently, a leader current begins to flow from the cloud to the ground. This current and charge cause a corona effect on objects on the ground. One of the upward currents created by these objects catches the leader current and carries it to the ground.

## CHARACTERISTICS OF LIGHTNING

- The formation of the leading edge occurs step by step. Lightning travels 10-100 meters with each step.
- The waiting time between steps is 30-90 microseconds.
- The average speed of lightning is 50,000 km/s.
- The amount of electrical charge discharged in a lightning event is 10-20 A.s (1 A.s = 1 coulomb).
- Lightning protection standards assume that the peak value (100 kA) of the lightning reaches 90% within 10 microseconds, and the decay time is 350 microseconds.
- Current/time graph of lightning obtained experimentally in the laboratory:

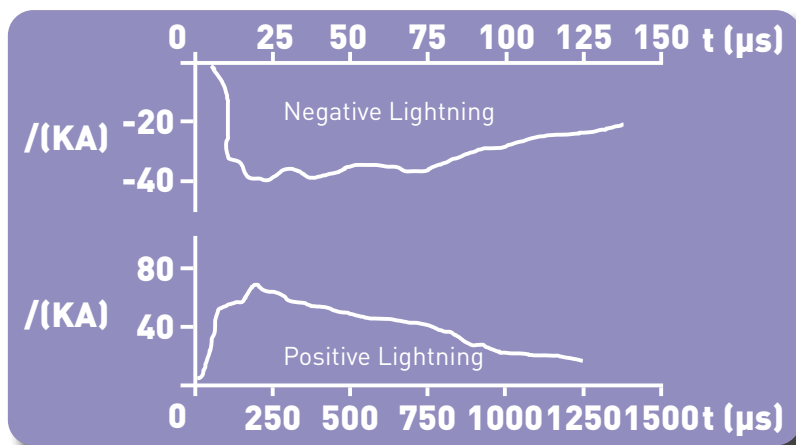

## NECESSITY OF PROTECTION

Lightning is a natural disaster like earthquakes, tornadoes, and floods. Unlike other disasters, it does not cause damage to large areas, but it causes significant problems where it strikes. Unlike other disasters, it is not rare; millions of lightning strikes occur every day. Lightning strikes cause damage to people, animals, buildings, and devices. This damage is classified into four different categories:

- Loss of life and injury: directly threatens people and animals.
- Material losses: fires in buildings and malfunctions in electrical devices we use.
- Service losses: electricity, water, and gas distribution networks, services provided over the internet.
- Cultural losses: Damage to historical artifacts

To protect yourself from the wrath of lightning, it is essential to understand the disaster and act consciously. People should protect themselves in open areas and take necessary precautions for their structures.

## RISK ANALYSIS MANAGEMENT and PROTECTION

In order to provide conscious protection, it is first necessary to thoroughly analyze the structure to be protected, determine the measures to be taken against the risk, and take the appropriate measures.

The analysis of the structure and related engineering work must be carried out in accordance with TS EN 62305. The lightning protection level "YKS" is calculated using the calculation method given in this standard and the NFC 17-102 standard. YKS is defined by levels ranging from one to four. Level 1 represents the highest risk level, while Level 4 indicates the lowest risk level. The appropriate protection system is determined based on the structure's YKS level.

To implement the calculated and designed lightning protection system, high-quality products and skilled labor are required. Products compliant with the TS EN 62561 standard are considered high-quality products. Unfortunately, there is no standard for skilled labor in our country. Companies' SMM certificates, ISO management systems, engineering staff, and expertise should serve as evaluation criteria.

## RADSAN PROTECTION CONCEPT

The most advanced technologies and safest products should be used for true security.

With the experience we have gained since 1953, we believe that there are four basic rules for true protection.



### 1. EARLY WARNING:

The best way to protect yourself from natural disasters is to receive advance warning. Thanks to the first and only lightning warning system in Turkey, which we have established, people can be warned one hour in advance, minimizing loss of life and property damage.



### 2. CATCH THE LIGHTNING:

An external lightning protection system is designed to attract lightning strikes. This allows lightning to be conducted to the ground via a controlled path.

Designing a correct, durable system prevents potential fires, loss of life, injury, and material losses.



### 3. GROUNDING:

Lightning, which is a very powerful electrical phenomenon, cannot be neutralized.

The only way to avoid damage is to ground it.

Therefore, GROUNDING is the basis of protection.



### 4. PROTECT ELECTRONIC SYSTEMS:

Lightning is a high-voltage event, and even if it is properly grounded, today's sensitive electronic systems can be damaged. Special protection methods should be applied for televisions, computers, smart buildings, advanced technology automation systems, and communication systems in homes.

# LIGHTNING PROTECTION

**CATCH THE LIGHTNING**

**GROUNDING**

## LIGHTNING ROD SYSTEM



## CAGE SYSTEM

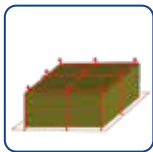

## LIGHTNING PROTECTION AND EARTHING INSTALLATION PRODUCTS

### A.G. PARAFUDR SİSTEMİ

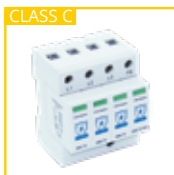

### GROUNDING SYSTEM



## AIRCRAFT WARNING LAMPS



**RWL.01**

**SINGLE:** Single aircraft warning in one lamp

**2 in 1:** Dual aircraft warning in one lamp

### AIRCRAFT WARNING LIGHT

#### TEKLI

<b>WORKING VOLTAGE</b>	48-250 V AC / DC
	12-36 V AC / DC
	12/24/48 V DC
<b>FLASH DURATION</b>	1 Hz.
<b>TEST RANGE</b>	Max. 15 minute
<b>ELECTRICAL POWER</b>	Max. 4 watt
<b>MODE</b>	<ul style="list-style-type: none"> <li>• DAYTIME (24 hours) CONTINUOUS LIGHT</li> <li>• DAYTIME CONTINUOUS FLASH (FLASHES)               <ul style="list-style-type: none"> <li>• CONTINUOUS LIGHT IN THE DARK</li> </ul> </li> <li>• FLASH IN THE DARK (FLASHES ON AND OFF)</li> </ul>
<b>ALARM OUTPUT</b>	Dry Contact
<b>NC</b>	No Power
<b>UPPER PART</b>	Clear Glass, Clear Plastic
<b>LOWER PART</b>	Aluminum, ABS Plastic
<b>SIZE</b>	Ø110 mm, H:220/160 mm
<b>POLE DIAMETER</b>	42 mm, 1 <sup>1/4</sup> "

### LED FEATURES

<b>LED NO</b>	4 Power Led
<b>POWER (WATT)</b>	3 W
<b>WAVELENGTH</b>	620 - 630nm
<b>LIGHTING</b>	min. 50 lumen / LED
<b>TERMS OF USE</b>	50.000 clock

Please request a quote for different types.



## UÇAK İKAZ LAMBALARI / AIRCRAFT WARNING LAMPS



İKİLİ UÇAK İKAZ LAMBASI

### UÇAK İKAZ LAMBASI

#### 2 in 1 İKİLİ UÇAK İKAZ LAMBASI

<b>WORKING VOLTAGE</b>	48-250 V AC / DC
	12-36 V AC / DC
	12/24/48 V DC
<b>FLASH DURATION</b>	1 Hz.
<b>TEST RANGE</b>	Max. 15 minute
<b>ELECTRICAL POWER</b>	Max. 4 watt
<b>MODE</b>	<ul style="list-style-type: none"> <li>• DAYTIME (24 hours) CONTINUOUS LIGHT</li> <li>• DAYTIME CONTINUOUS FLASH (FLASHES) <ul style="list-style-type: none"> <li>• CONTINUOUS LIGHT IN THE DARK</li> </ul> </li> <li>• FLASH IN THE DARK (FLASHES ON AND OFF)</li> </ul>
<b>ALARM OUTPUT</b>	Dry Contact
<b>NC</b>	LED Failure
<b>UPPER PART</b>	Güç Yok
<b>LOWER PART</b>	Şeffaf Cam, Şeffaf Plastik
<b>SIZE</b>	Aluminum, ABS Plastic
<b>POLE DIAMETER</b>	Ø110 mm, H:220/160 mm
<b>POLE DIAMETER</b>	42 mm, 1 <sup>1/4</sup> "

### LED FEATURES

<b>LED NO</b>	4 Power Led
<b>POWER (WATT)</b>	3 W
<b>WAVELENGTH</b>	620 - 630nm
<b>LIGHTING</b>	min. 50 lumen / LED
<b>TERMS OF USE</b>	50.000 clock

Please request a quote for different types.



## Solar Panel Power Supply / RSWL.01

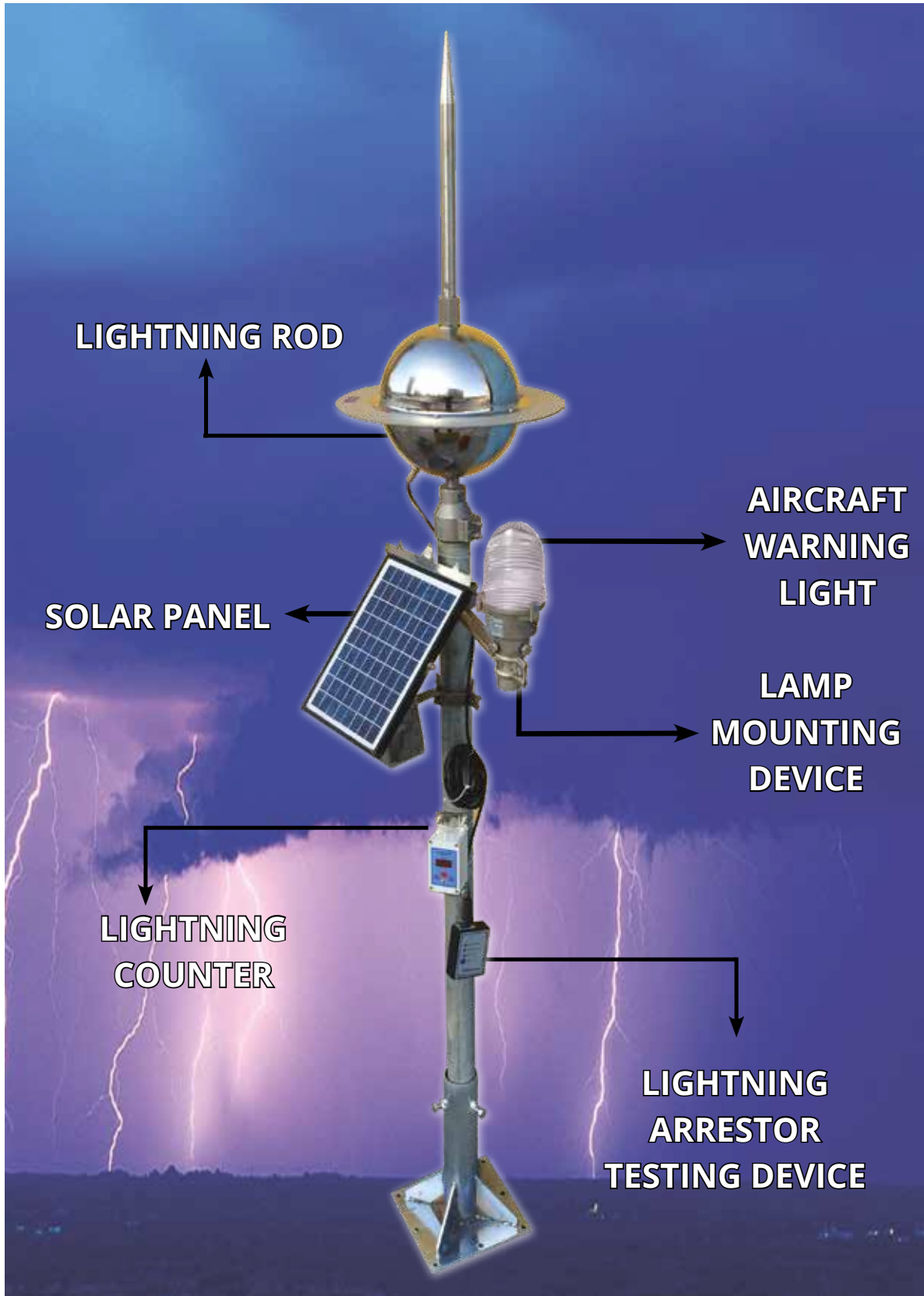

# LIGHTNING PROTECTION

## WHAT IS AN ACTIVE LIGHTNING ROD?

No technology has yet been developed that can prevent lightning from forming.

Active lightning rod technology has been developed to capture lightning approaching a structure and conduct it to the ground via a safe path.

Active lightning protection begins capturing lightning earlier than other objects within its protection radius, thereby capturing the lightning.

This time is called the "early warning time," expressed in microseconds, and determines the protection radius of the lightning protection system.

## ACTIVE LIGHTNING PROTECTION RADIUS

Table of Maximum Protection Radius Possible According to NFC 17-102:

Protection Level	I	II	III	IV
Protection Radius, $\Delta t=60 \mu s$	79m	87m	97m	107m

In laboratory environments, larger protection radii are obtained, but relevant standards do not accept protection radii larger than those in the table above for safety reasons.



**!!! Please be cautious of companies that promise a large protection radius.**

**Do not be deceived. !!!**

## ACTIVE LIGHTNING ROD TESTS

Active lightning rods are designed and manufactured in accordance with TSE 13709 French standard NFC 17-102. To comply with the standards, a lightning rod must successfully pass the following tests in order:

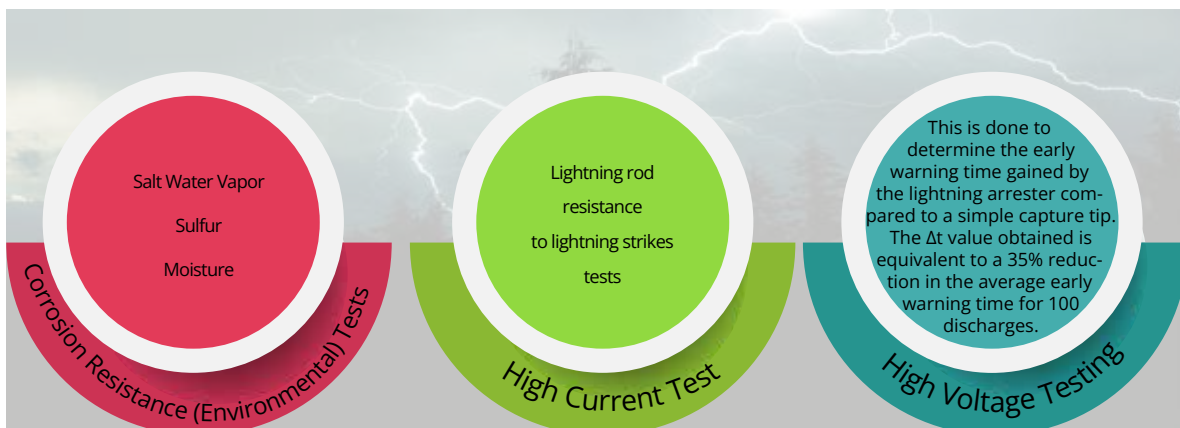

# PREVECTRON

## TESTED WITH REAL LIGHTNING, THE ONLY LIGHTNING ROD



Real Lightning Test  
Performed by Triggering  
Lightning with a Rocket



**Advanced Technology, NFC 17-102: Compliant with 2011 version!**  
The ion generator charges using the electric field in the atmospheric area. Thanks to the detection system, the ion generator activates immediately before a lightning discharge and captures the lightning by ionizing the air.

		h(m) Distance from the roof of the building to the lightning rod					
		h(m)	2	3	4	5	10
Protection Level 1	Protection Semi-diameter	S 6.60	31	47	63	79	79
		S 4.50	27	41	55	68	69
		S 3.40	23	36	46	58	59
		TS 3.40	23	36	46	58	59
		TS 2.25	17	24	34	42	44
Protection Level 2	Protection Semi-diameter	h(m)	2	3	4	5	10
		S 6.60	34	52	68	86	88
		S 4.50	30	45	60	76	77
		S 3.40	26	39	52	65	67
		TS 3.40	26	39	52	65	67
Protection Level 3	Protection Semi-diameter	h(m)	2	3	4	5	10
		S 6.60	39	58	78	97	99
		S 4.50	34	52	69	86	88
		S 3.40	30	45	60	75	77
		TS 3.40	30	45	60	75	77
Protection Level 4	Protection Semi-diameter	h(m)	2	3	4	5	10
		S 6.60	43	64	85	107	109
		S 4.50	38	57	76	95	98
		S 3.40	33	50	67	84	87
		TS 3.40	33	50	67	84	87
		TS 2.25	26	39	52	65	69

### Counters



**Classic Counter**  
Displays the number of  
lightning strikes



**Advanced Counter**  
Lightning Count,  
Date, and Lightning  
Strength

# TESLA

## Ultra-High Performance

As a result of lightning strikes applied with the high voltage test system, the early current dissipation feature was determined as  $\Delta T = 81 \mu s$ . It is 35% higher than the highest level set by international standards.

## High Strength

It can withstand lightning strikes of 100 kA applied with a high current test system. Successfully completed tests for resistance to corrosive environments. Successfully tested to withstand extreme weather conditions. Vibration resistant.

## IP65

It has high resistance to water and dust. It can be used safely in very rainy and humid regions.

## Ultra-High Quality

It has been certified to comply with all national (TS 13709) and international (NFC 17-102:2011) standards. It is produced under a European patent and controlled according to the highest quality standards.

## Testable

With the tester, you can test at any time and see that the lightning rod is in working condition. Please keep in mind that lightning rods may get damaged by lightning strikes. Therefore they need to be tested regularly

## Long Warranty

Working warranty is 2 years. The operating warranty can be extended with an additional warranty package. There is a 15-year stainless warranty.

## Reliable

Each Tesla is tested with the 6-step quality control principle. Tesla is designed and manufactured with Radsan's long years of knowledge and experience. Radsan has produced more than 600.000 lightning rods in 23 years and they are working successfully in more than 100 countries under different conditions.

## Complementary Products



Test Device



Aviation Lamp



Counter



## ÖZELLİKLER

Model	RADSAN
Kod	TESLA-ST
Early Triggerring Time	60 $\mu s$
Test Performance	81 $\mu s$
Current Withstand 10/350 $\mu s$	100kA
Corrosion Resistance TS 9258 / EN ISO 6988	High Strength
Protection Class (Dust / Water) TS 3033 / EN 60529	IP 65
Working Temperature TS EN 60068-2-1 / TS EN 60068-2-2	-20°C / +60°C
Testable	Yes
Material	Stainless Steel + Aluminium
Pipe Connection	2" Galvanized Pipe
Product Weight	5,6 kg
Diameter x Height	Ø395x806 cm
Package Information	Weight 6,8 kg 57 x 15 x 14.5 cm
Warranty Period	2 Years Functional 15 Years Pysical Deformation

Licon Insulated Conductor



# KINETIC

## Ideal Performance

As a result of lightning strikes applied with the high voltage test system, the early current dissipation feature was determined as  $\Delta T=60$

## High Strength

It can withstand lightning strikes of 200 KA applied with a high current test system. It has two times higher strength than the highest level determined by international standards. Resistance to corrosive environments, extreme weather condition withstanding, vibration tests successfully completed.

## IP65

It has high resistance to water and dust. It can be used safely in very rainy and humid areas.

## High Quality

It has been certified to comply with all national (TS 13709) and international (NFC 17-102:2011) standards.

## Testable

With the tester, you can test at any time and see that the lightning rod is in working condition. Please keep in mind that lightning rods may get damaged by lightning strikes. Therefore they need to be tested regularly

## Long Warranty

Working warranty is 2 years. The operating warranty can be extended with an additional warranty package. There is a 15-year stainless warranty.

## Reliable

Each Kinetic is tested with the 6-step quality control principle. Kinetic Pro is designed and manufactured with Radsan's long years of knowledge and experience. Radsan has produced more than 600.000 lightning rods in 23 years and they are working successfully in more than 100 countries under different conditions.

## Complementary Products



## ÖZELLİKLER

Model	RADSAN
Kod	KINETIC
Early Triggerring Time	60 $\mu$ s
Test Performance	61 $\mu$ s
Current Withstand 10/350 $\mu$ s	200kA
Corrosion Resistance TS 9258 / EN ISO 6988	High Strength
Protection Class (Dust / Water) TS 3033 / EN 60529	IP 65
Working Temperature TS EN 60068-2-1 / TS EN 60068-2-2	-20°C / +60°C
Testable	Yes
Material	Aluminium
Pipe Connection	2" Galvanized Pipe
Product Weight	840 gr
Diameter x Height	11,5 x 44 cm
Package Information	Weight 1.3 kg 13 x 14 x 55 cm
Warranty Period	2 Years Functional 15 Years Pysical Deformation

Licon Insulated Conductor



# KINETIC PRO

## High Performance

As a result of lightning strikes applied with the high voltage test system, the early current dissipation feature was determined as  $\Delta T = 68 \mu s$ . It is 13% higher than the highest level set by international standards.

## High Strength

It can withstand lightning strikes of 200 kA applied with a high current test system. It has two times higher strength than the highest level determined by international standards. Successfully completed tests for resistance to corrosive environments. Successfully tested to withstand extreme weather conditions. Vibration resistant.

## IP65

It has high resistance to water and dust. It can be used safely in very rainy and humid regions.

## High Quality

It has been certified to comply with all national (TS 13709) and international (NFC 17-102:2011) standards.

## Testable

With the tester, you can test at any time and see that the lightning rod is in working condition. Please keep in mind that lightning rods may get damaged by lightning strikes. Therefore they need to be tested regularly.

## Long Warranty

Working warranty is 2 years. The operating warranty can be extended with an additional warranty package. There is a 15-year stainless warranty.

## Reliable

Each Kinetic Pro is tested with the 6-step quality control principle. Kinetic Pro is designed and manufactured with Radsan's long years of knowledge and experience. Radsan has produced more than 600.000 lightning rods in 23 years and they are working successfully in more than 100 countries under different conditions.



## ÖZELLİKLER

Model	RADSAN
Kod	KINETIC-PRO
Early Triggerring Time	60 $\mu s$
Test Performance	68 $\mu s$
Current Withstand 10/350 $\mu s$	200kA
Corrosion Resistance TS 9258 / EN ISO 6988	High Strength
Protection Class (Dust / Water) TS 3033 / EN 60529	IP 65
Working Temperature TS EN 60068-2-1 / TS EN 60068-2-2	-20°C / +60°C
Testable	Yes
Material	Aluminium
Pipe Connection	2" Galvanized Pipe
Product Weight	1,9 kg
Diameter x Height	14x52 cm
Package Information	Weight 2.4 kg 57 x 15 x 14.5 cm
Warranty Period	2 Years Functional 15 Years Pyshical Deformation

## Complementary Products



Licon Insulated Conductor

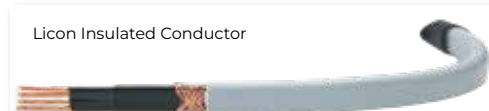

## LIGHTNING ROD TEST DEVICE



**TS.TC**



**RAD.TC**



**INDELEC**

Testers test the operability status of lightning rods.

Factors such as lightning, corrosive effects of the external atmosphere, vibration can cause lightning arresters to malfunction. operability status of lightning rods.

Factors such as lightning, corrosive effects of the external atmosphere, vibration can cause lightning arresters to be checked at least once a year.

## LIGHTNING COUNTERS



Lightning Strike Counters count the lightning strikes on down conductors, They can detect lightning strikes between 300A and 100 kA.

## SMART CODING

Please use the following letter and number Codes to determine the combination of the metal desired product , the coat-ing and the type of bolt-nut group

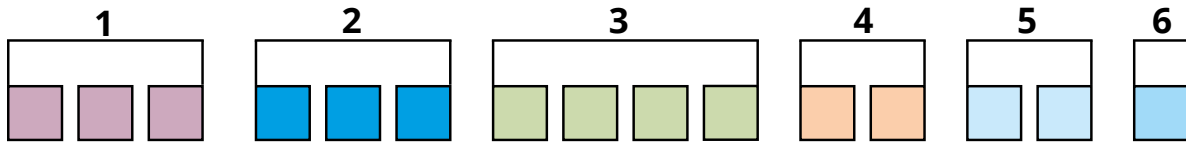

1. Product Group Code
- 2 Product Class Codes
3. Your Choice Of Size

4. Your Choice Of First Product Raw Material And Coating
- 5 Second Product Raw Material And Coating Preference
6. your choice of bolts and nuts

## RAW MATERIAL, COATING AND BOLT SELECTION TABLE

RAW MATERIAL		COATING		BOLT	
Code	Explication	Code	Explication	Code	Explication
D	Iron And Steel	1	Electro Galvanized	DC	Galvanized
B	Copper	2	Hot Galvanized	NC	Stainless
N	Stainless	3	Electro Copper	SC	Brass
A	Aluminum	4	Electro Tin		
S	Brass	5	Nickel		
F	Bronze	6	Black isolations		
G	Cast Iron	7	Yellow-green isolation		
P	Plastic				
C	Concrete				

## Sample Encodings



**10 µm. Bakır Kaplama/ Coating thickness**

Code	Material/Coating	Dia.	Lenght
TES.16.1000	D1-D3-B-N-D2	16 mm	1000 mm
TES.16.1200	D1-D3-B-N-D2	16 mm	1200 mm

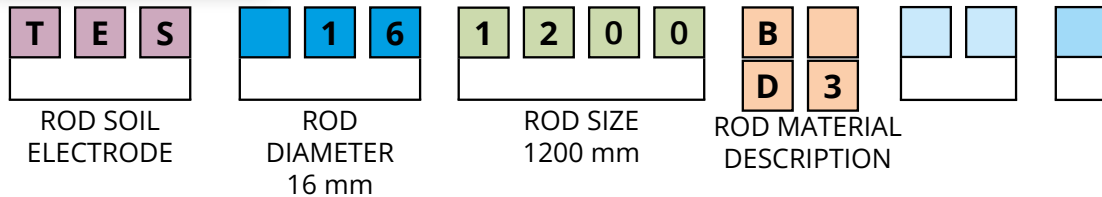



**Screw Type Conductor Clips**

Kod Code	Casing Material/Kaplama Material/Coating	Civata Bolt	İletken Kesit Cross Section
IK.113.04	(D1+A)-(D1+B)-(D1+D1)-(D2+A)(D2+B)(D2+D2)-(N+A)-(N+B)-(N+N)	DC-NC	1x50mm <sup>2</sup>
IK.113.05	(D1+A)-(D1+B)-(D1+D1)-(D2+A)(D2+B)(D2+D2)-(N+A)-(N+B)-(N+N)	DC-NC	1x70mm <sup>2</sup>
IK.113.06	(D1+A)-(D1+B)-(D1+D1)-(D2+A)(D2+B)(D2+D2)-(N+A)-(N+B)-(N+N)	DC-NC	1x95mm <sup>2</sup>

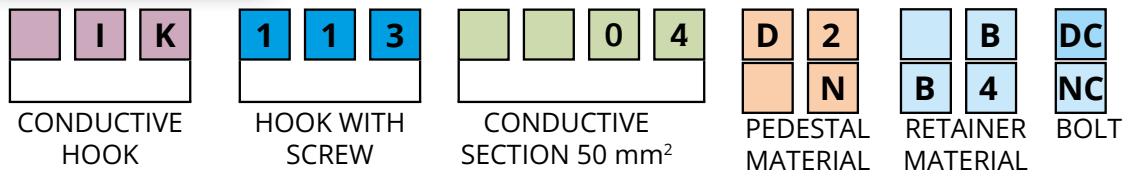



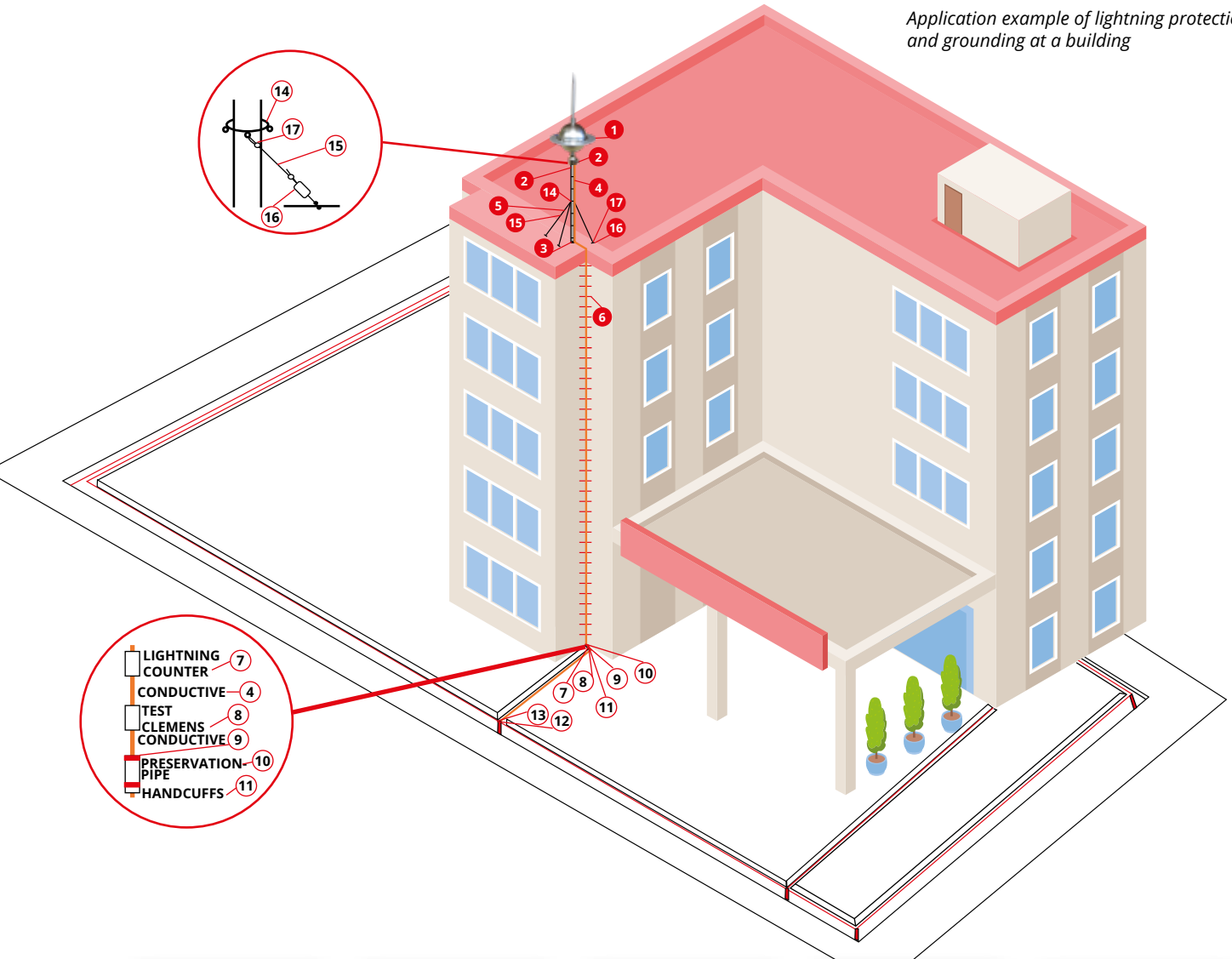

IK.113.04.D2.B.DC SCREW CONDUCTOR CROWN, FOR 50mm<sup>2</sup> CONDUCTOR, HOT DIP GALVANIZED COATED PEDAL, COPPER HOLDER, GALVANIZED  
IK.113.06.N.B4.NC SCREWED CONDUCTOR CROWN, FOR 95mm<sup>2</sup> CONDUCTOR, STAINLESS STEEL PAPER, TIN COATED COPPER HOLDER, STAINLESS BOLT

# APPLICATION EXAMPLE OF LIGHTNING PROTECTION AND GROUNDING AT A BUILDING

Application example of lightning protection and grounding at a building



-  LIGHTNING COUNTER 7
-  CONDUCTIVE TEST CLEMENS CONDUCTIVE 8
-  PRESERVATION PIPE 10
-  HANDCUFFS 11



# APPLICATION EXAMPLE OF LIGHTNING PROTECTION AND GROUNDING AT A GAS STATION

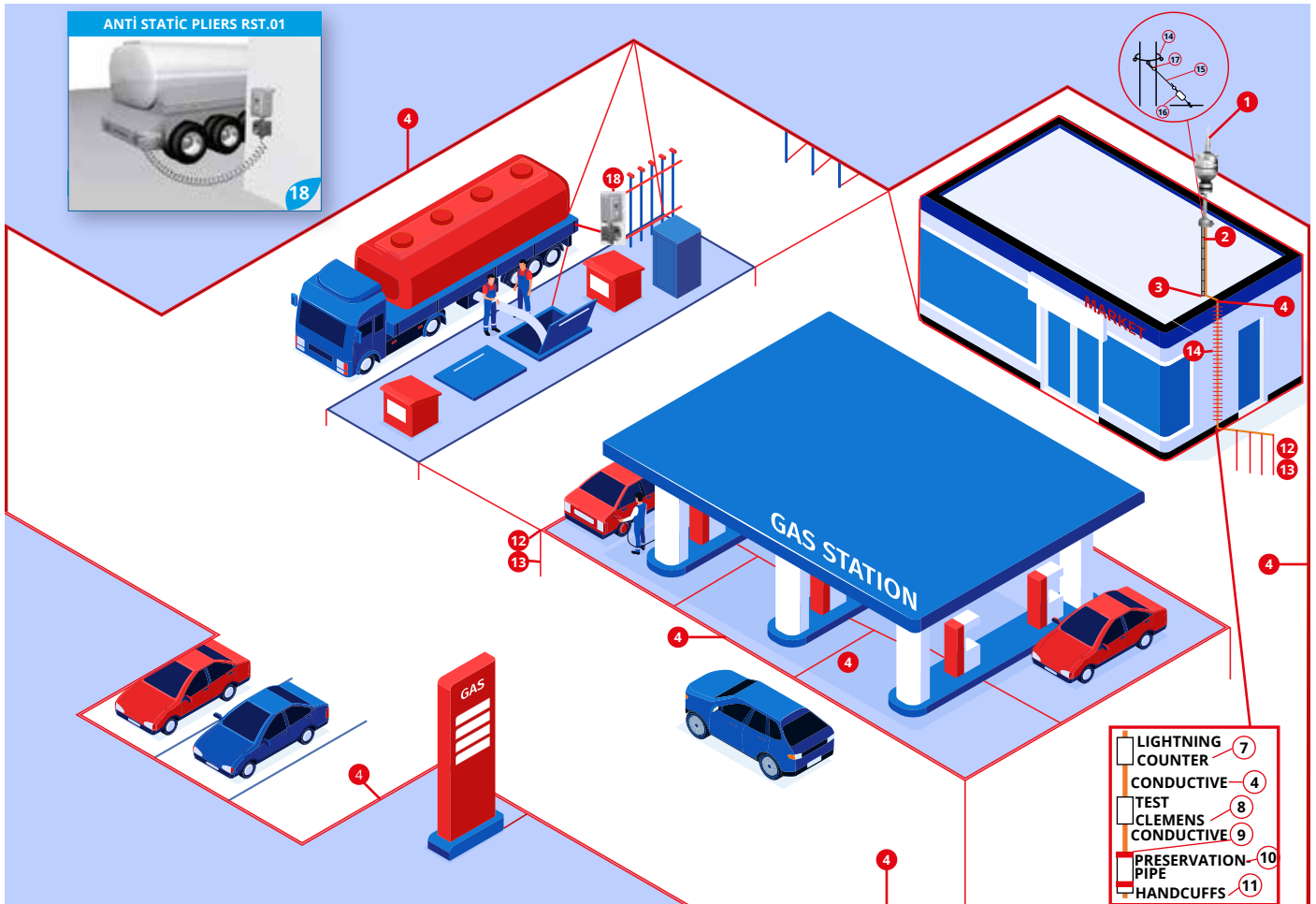

Application example of lightning protection and grounding at a gas station



# APPLICATION EXAMPLE OF LIGHTNING PROTECTION AND GROUNDING AT A LATTICE TOWER

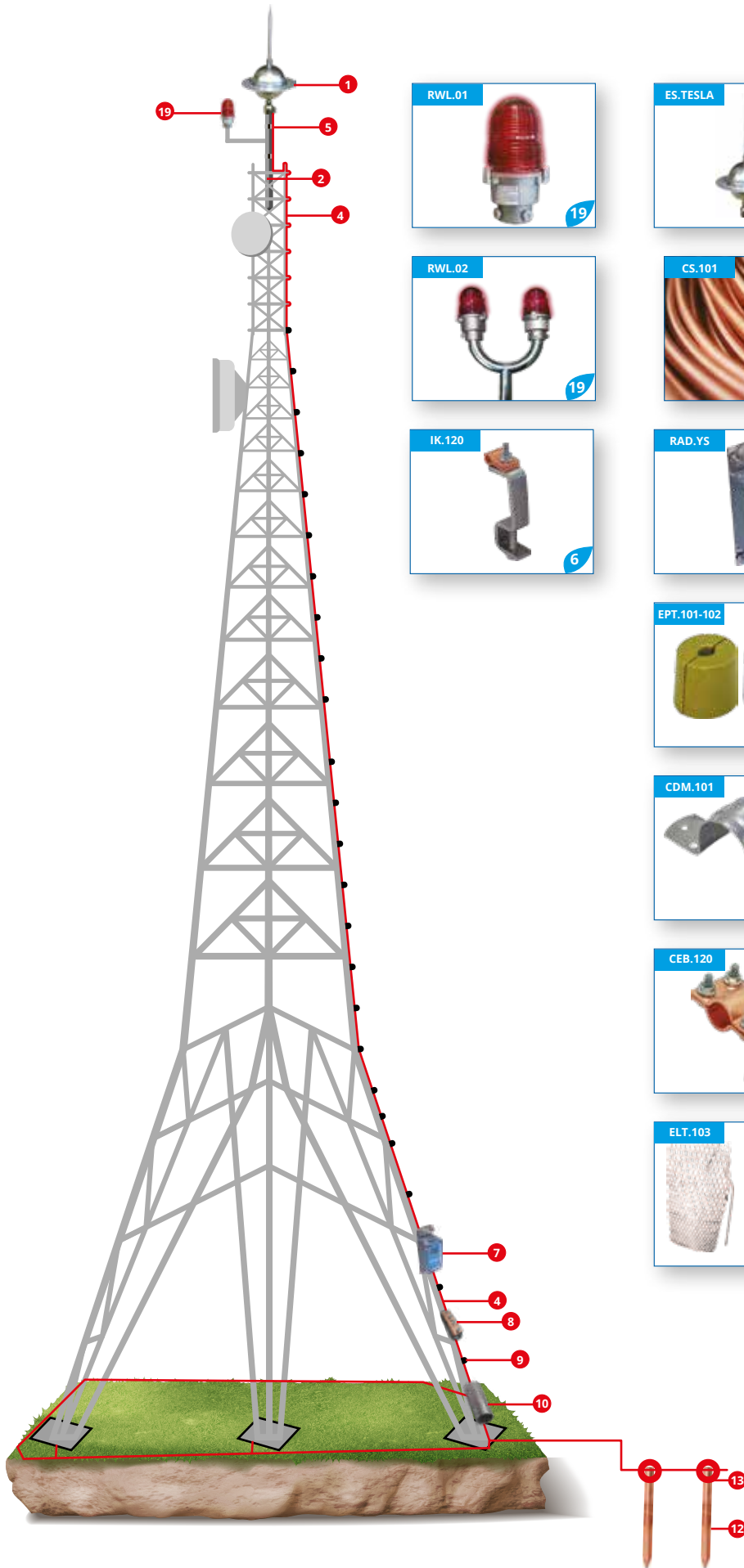

Application example of lightning protection and grounding at a lattice tower

# APPLICATION EXAMPLE OF LIGHTNING PROTECTION AND GROUNDING AT A MONOPOLE MAST

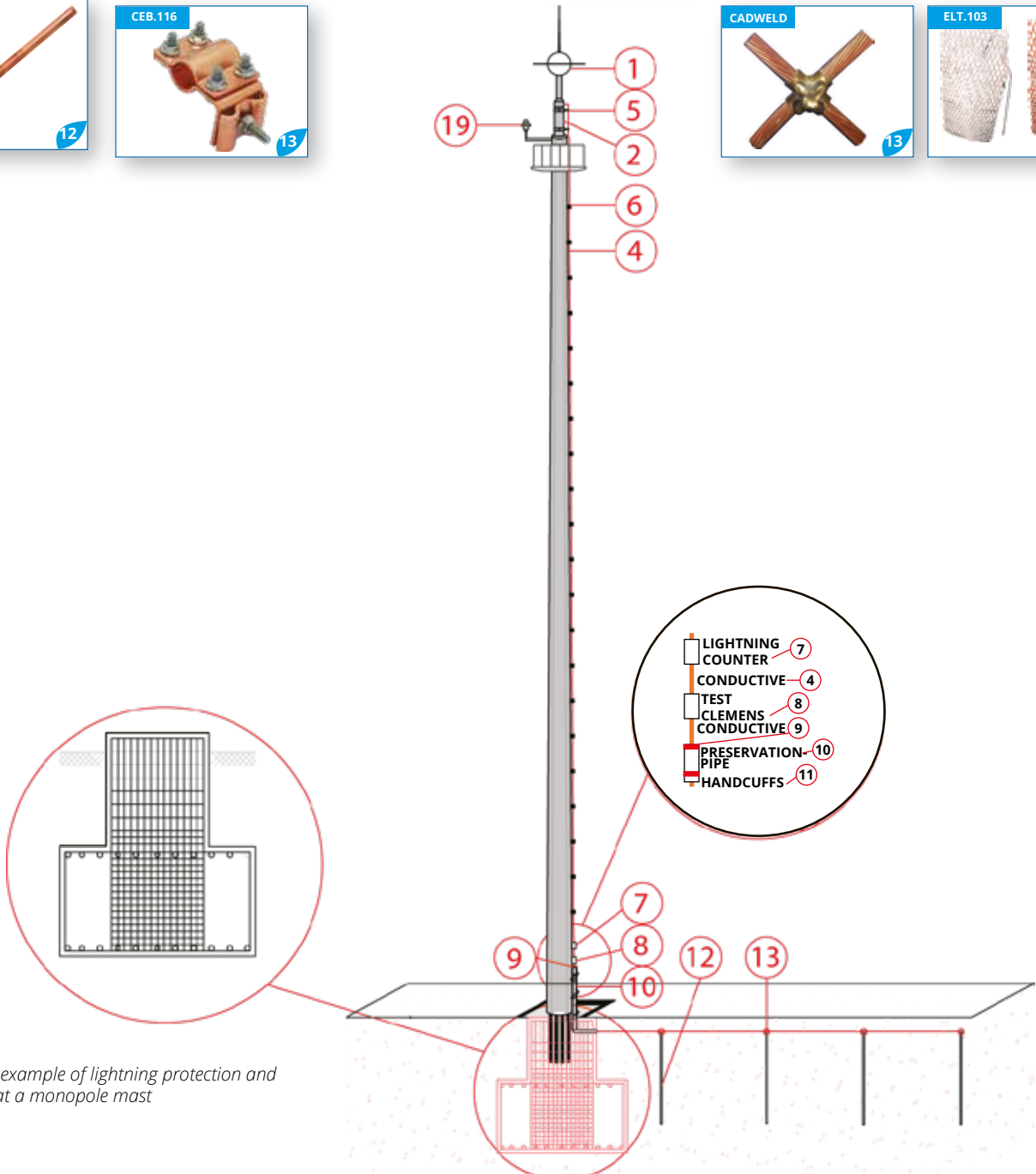

Application example of lightning protection and grounding at a monopole mast

# APPLICATION EXAMPLE OF LIGHTNING PROTECTION AND GROUNDING AT A MAST

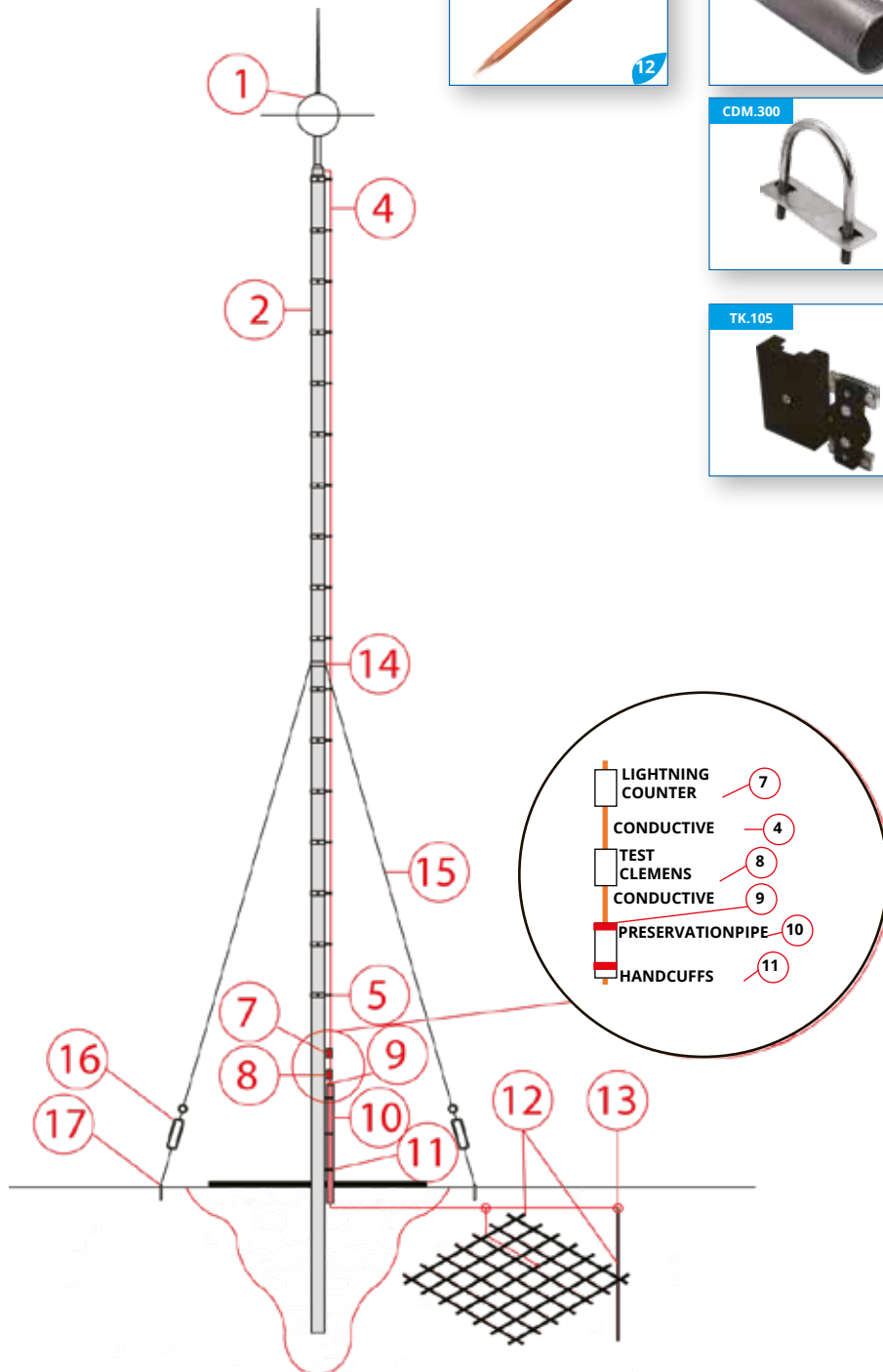

# MASTS

## Polygon Mast



Code	Material / Coating	Height (mm)
PLG.10	D2	10
PLG.12	D2	12
PLG.14	D2	14
PLG.15	D2	15
PLG.15	D2	16
PLG.18	D2	18
PLG.20	D2	20
PLG.25	D2	25

## Fold Over, Short Mast

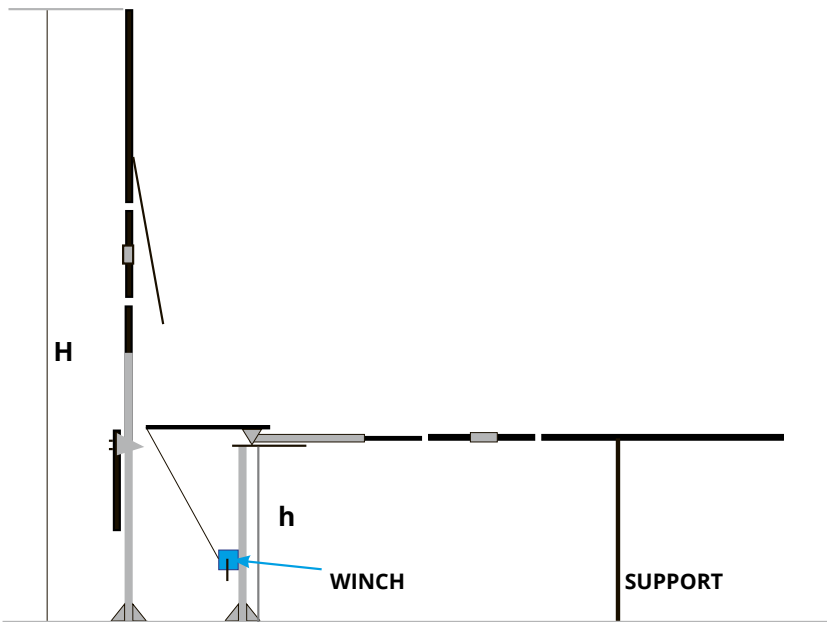

Please add the number corresponding to the "bending"

Code	Material	$\Sigma H(m)$	Folding Height (h), m				
			1,75	2	2,25	2,5	3
FOM.14	D2-A	14				X	X
FOM.12		12			X	X	X
FOM.10		10		X	X	X	X
FOM.08		8	X	X	X	X	X
FOM.06		6	X	X	X	X	X
FOM.04		4	X	X	X	X	X

**MAIN MATERIAL**  
 A=Aluminium, B=Copper, D=Iron-Steel,  
 F=Bronze, G=Gray Cast Iron,  
 N=Stainless, P=Plastic, S=Brass

**COATINGS**  
 1=Electrogalvanizing, 2=Hot Dip Galvanizing, 3=Electrodeposited Copper,  
 4=Electrodeposited Tin, 5=Electrodeposited Chromium-Nickel,  
 6=Black Insulation, 7=Yellow-Green Insulation

**SCREW NUT**  
 DC=Galvanizing,  
 NC=Stainless,  
 SC=Brass

# MASTS

## Portable Mast

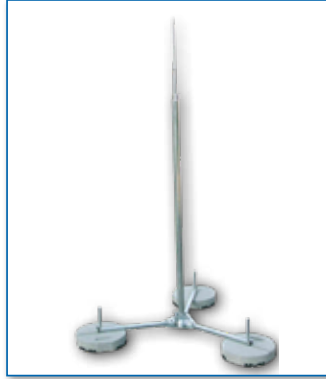

Code	Material Coating	Length (m)	Material / Dia. (mm)								Total Length	
			N/D 289	N/D 250	N/D 242	N/D 234	A 80	A 65	A 40	A 16		A 10
			SSM.106.01	D1-D2-N-A	3				1			
SSM.106.02		3							1	1	1	3
SSM.106.03	D1-D2-N-A	4				2				1	1	4
SSM.106.04		4							2	1	1	4
SSM.106.05	D1-D2-N-A	5				3				1	1	5
SSM.106.06		5							3	1	1	5
SSM.106.07	D1-D2-N-A	6			2,5	1,5				1	1	6
SSM.106.08		6							4	1	1	6
SSM.106.09	D1-D2-N-A	7			2,5	2,5				1	1	7
SSM.106.10		7							5	1	1	7
SSM.106.11	D1-D2-N-A	8			3,5	2,5				1	1	8
SSM.106.12		8							5,5	1,5	1	8
SSM.106.13	D1-D2-N-A	9		3	2	2				1	1	9
SSM.106.14		9						3,5	3	1,5	1	9
SSM.106.15	D1-D2-N-A	10	4				3	2			1	10
SSM.106.16	D1-D2-N-A	11	4				3	3			1	11
SSM.106.17	D1-D2-N-A	12	4				4	3			1	12
SSM.106.18	D1-D2-N-A	13	5				4	3			1	13
SSM.106.19	D1-D2-N-A	14	5				5	3			1	14

### MAIN MATERIAL

A=Aluminium, B=Copper, D=Iron-Steel, F=Bronze, G=Gray Cast Iron, N=Stainless, P=Plastic, S=Brass

### COATINGS

1=Electrogalvanizing, 2=Hot Dip Galvanizing, 3=Electrodeposited Copper, 4=Electrodeposited Tin, 5=Electrodeposited Chromium-Nickel, 6=Black Insulation, 7=Yellow-Green Insulation

### SCREW NUT

DC=Galvanizing, NC=Stainless, SC=Brass

# LIGHTNING MASTS FOR E.S.E AND AIR ROD (ALTERNATIVE TO POLYGON MASTS.) LLM SERIES LIGHTNING POSTS

## Flanged Mast

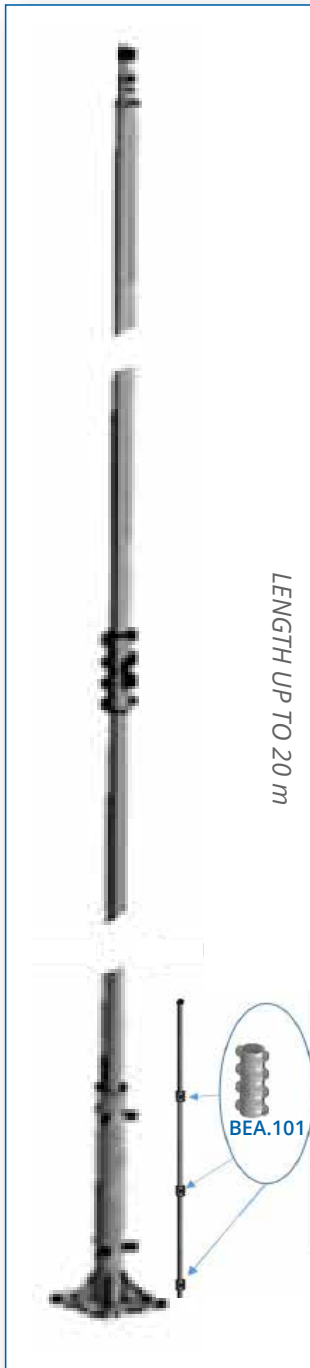

Code	Material	Mast Dia. (mm)			ΣL	Lente Support Wire
		60	76	89	m	
LLM.1.06	Galvanized Steel	6(3+3)			6	
LLM.2.06			6(3+3)			
LLM.3.06				6(3+3)		
LLM.1.07		1	6		7	
LLM.2.07		1		6		
LLM.3.07		1+6				
LLM.4.07			1+6			
LLM.5.07				1+6		
LLM.1.08		2	6		8	
LLM.2.08		2		6		
LLM.3.08			2	6		
LLM.4.08		2+6				
LLM.5.08			2+6			
LLM.6.08				2+6		
LLM.1.09		3	6		9	
LLM.2.09		3		6		
LLM.3.09			3	6		
LLM.4.09		3+6				
LLM.5.09			3+6			
LLM.6.09				3+6		
LLM.1.10	4	6		10		
LLM.2.10	4		6			
LLM.3.10		4	6			
LLM.4.10	4+6					
LLM.5.10		4+6				
LLM.6.10			4+6			

Lightning rod masts combined with clamps, transportation length may be approximately 3 or 4 m

# LIGHTNING ROD INSTALLATION MATERIALS

## Lightning Arrester (ESE) Mast



Code	Material / Coating	Dia. (inch)	Lenght
CD.101.05	D2 - N	1.5"	6000 mm
CD.101.06	D2 - N	2"	6000 mm
CD.101.07	D2 - N	2.5"	6000 mm

## Mast Joint



Code	Material / Coating	Dia. (inch)	Lenght
BEA.101.01	D2 - N	2"	300 mm
BEA.101.02	D2 - N	2.5"	300 mm

### MAIN MATERIAL

A=Aluminium, B=Copper, D=Iron-Steel,  
F=Bronze, G=Gray Cast Iron,  
N=Stainless, P=Plastic, S=Brass

### COATINGS

1=Electrogalvanizing, 2=Hot Dip Galvanizing, 3=Electrodeposited Copper,  
4=Electrodeposited Tin, 5=Electrodeposited Chromium-Nickel,  
6=Black Insulation, 7=Yellow-Green Insulation

### SCREW NUT

DC=Galvanizing,  
NC=Stainless,  
SC=Brass

# LIGHTNING ROD INSTALLATION MATERIALS

## Adapter Between E.S.E. and Mast



Code	Material / Coating	Dia. (inch)
PDA.104.01	A	2"

**For Tesla-ST and Petex Lightning Arresters**

## For French Type Lightning Arrester



Code	Material / Coating	Description	Dia. (inch)
PDA.102.01	D1 - D2	Adaptör Adapter	2"
PDA.102.02	D1 - D2	Adaptör Adapter	2"½
PDA.102.03	D1 - D2	Adaptör Adapter	3"

## For French Type Lightning Arrester



Code	Material / Coating	Description	Dia. (inch)
PDA.103.01	D1 - D2	Adaptör Adapter	2"
PDA.103.02	D1 - D2	Adaptör Adapter	2"½
PDA.103.03	D1 - D2	Adaptör Adapter	3"

# LIGHTNING ROD INSTALLATION MATERIALS

## Mast Holder For Flat Surfaces



Kod Code	Material / Coating	Pipe Dia. (inch)
CDT.201.05	D1-D2-N	2"
CDT.201.06	D1-D2-N	2"½
CDT.201.07	D1-D2-N	3"

## Mast Holder For Flat Surfaces, Corner Type



Code	Material / Coating	Pipe Dia. (inch)
CDT.301.05	D1-D2-N	2"
CDT.301.06	D1-D2-N	2"½
CDT.301.07	D1-D2-N	3"

## Mast Holder For Walls



Code	Material / Coating	Pipe Dia. (inch)
CDT.401.02-07	D1-D2-N	1" - 3"

### MAIN MATERIAL

A=Aluminium, B=Copper, D=Iron-Steel, F=Bronze, G=Gray Cast Iron, N=Stainless, P=Plastic, S=Brass

### COATINGS

1=Electrogalvanizing, 2=Hot Dip Galvanizing, 3=Electrodeposited Copper, 4=Electrodeposited Tin, 5=Electrodeposited Chromium-Nickel, 6=Black Insulation, 7=Yellow-Green Insulation

### SCREW NUT

DC=Galvanizing, NC=Stainless, SC=Brass

# LIGHTNING ROD INSTALLATION MATERIALS

## Mast Holder, Rotatable



Code	Material / Coating	Pipe Dia. (inch)
CDT.402.05	D1-D2-N	2"
CDT.402.06	D1-D2-N	2"½
CDT.402.07	D1-D2-N	3"

## Mast Clamp For Wall



Code	Material / Coating	Pipe Dia. (inch)
CDT.101.05	D1-D2-N	2"
CDT.101.06	D1-D2-N	2"½
CDT.101.07	D1-D2-N	3"

## U Bolt With Bar



Code	Material / Coating	Pipe Dia. (inch)	Nut
CDM.300.00	D1-D2-N	½"	DC-NC
CDM.300.01	D1-D2-N	¾"	DC-NC
CDM.300.02	D1-D2-N	1"	DC-NC
CDM.300.03	D1-D2-N	1" ¼	DC-NC
CDM.300.04	D1-D2-N	1" ½	DC-NC
CDM.300.05	D1-D2-N	2"	DC-NC
CDM.300.06	D1-D2-N	2"½	DC-NC
CDM.300.07	D1-D2-N	3"	DC-NC

# LIGHTNING ROD INSTALLATION MATERIALS

## Mast / Plone Clamp “Adjustable Type”



Code	Material / Coating	Pipe Dia. (inch)
CDS.100.00	D1-D2-N	½"↔3"

## Type U Stud with Pedestal



Code	Material / Coating	Pipe Dia. (inch)
CDS.100.04	D1-D2-N	1" - 3"

## Mast Clamp For Wall



Code	Material / Coating	Pipe Dia. (inch)
CDM.101.00	D1-D2-N	½"
CDM.101.01	D1-D2-N	¾"
CDM.101.02	D1-D2-N	1"
CDM.101.03	D1-D2-N	1¼"
CDM.101.04	D1-D2-N	1½"
CDM.101.05	D1-D2-N	2"
CDM.101.06	D1-D2-N	2½"
CDM.101.07	D1-D2-N	3"

**MAIN MATERIAL**

A=Aluminium, B=Copper, D=Iron-Steel, F=Bronze, G=Gray Cast Iron, N=Stainless, P=Plastic, S=Brass

**COATINGS**

1=Electrogalvanizing, 2=Hot Dip Galvanizing, 3=Electrodeposited Copper, 4=Electrodeposited Tin, 5=Electrodeposited Chromium-Nickel, 6=Black Insulation, 7=Yellow-Green Insulation

**SCREW NUT**

DC=Galvanizing, NC=Stainless, SC=Brass

# LIGHTNING ROD INSTALLATION MATERIALS

## Conductor Holder for Mast



Code	Material / Coated	Bolt Dia.	Cross-Section
IK.122.20.04	(D1+B)-(D1+D1)-(D2+B)-(D2+D2)-(N+B)-(N+N)	DC-NC 2"	1x50mm <sup>2</sup>
IK.122.20.05	(D1+B)-(D1+D1)-(D2+B)-(D2+D2)-(N+B)-(N+N)	DC-NC 2"	1x70mm <sup>2</sup>
IK.122.20.06	(D1+B)-(D1+D1)-(D2+B)-(D2+D2)-(N+B)-(N+N)	DC-NC 2"	1x95mm <sup>2</sup>
IK.122.20.24	(D1+B)-(D1+D1)-(D2+B)-(D2+D2)-(N+B)-(N+N)	DC-NC 2"	2x50mm <sup>2</sup>
IK.122.20.25	(D1+B)-(D1+D1)-(D2+B)-(D2+D2)-(N+B)-(N+N)	DC-NC 2"	2x70mm <sup>2</sup>
IK.122.20.26	(D1+B)-(D1+D1)-(D2+B)-(D2+D2)-(N+B)-(N+N)	DC-NC 2"	2x95mm <sup>2</sup>
IK.122.20.31	(D1+B)-(D1+D1)-(D2+B)-(D2+D2)-(N+B)-(N+N)	DC-NC 2"	20x3-25x5 mm
IK.122.20.32	(D1+B)-(D1+D1)-(D2+B)-(D2+D2)-(N+B)-(N+N)	DC-NC 2"	30x2-30x5 mm
IK.122.20.33	(D1+B)-(D1+D1)-(D2+B)-(D2+D2)-(N+B)-(N+N)	DC-NC 2"	40x3-40x5 mm
IK.122.25.04	(D1+B)-(D1+D1)-(D2+B)-(D2+D2)-(N+B)-(N+N)	DC-NC 2" <sup>1</sup> / <sub>2</sub>	1x50mm <sup>2</sup>
IK.122.25.05	(D1+B)-(D1+D1)-(D2+B)-(D2+D2)-(N+B)-(N+N)	DC-NC 2" <sup>1</sup> / <sub>2</sub>	1x70mm <sup>2</sup>
IK.122.25.06	(D1+B)-(D1+D1)-(D2+B)-(D2+D2)-(N+B)-(N+N)	DC-NC 2" <sup>1</sup> / <sub>2</sub>	1x95mm <sup>2</sup>
IK.122.25.24	(D1+B)-(D1+D1)-(D2+B)-(D2+D2)-(N+B)-(N+N)	DC-NC 2" <sup>1</sup> / <sub>2</sub>	2x50mm <sup>2</sup>
IK.122.25.25	(D1+B)-(D1+D1)-(D2+B)-(D2+D2)-(N+B)-(N+N)	DC-NC 2" <sup>1</sup> / <sub>2</sub>	2x70mm <sup>2</sup>
IK.122.25.26	(D1+B)-(D1+D1)-(D2+B)-(D2+D2)-(N+B)-(N+N)	DC-NC 2" <sup>1</sup> / <sub>2</sub>	2x95mm <sup>2</sup>
IK.122.25.31	(D1+B)-(D1+D1)-(D2+B)-(D2+D2)-(N+B)-(N+N)	DC-NC 2" <sup>1</sup> / <sub>2</sub>	20x3-25x5 mm
IK.122.25.32	(D1+B)-(D1+D1)-(D2+B)-(D2+D2)-(N+B)-(N+N)	DC-NC 2" <sup>1</sup> / <sub>2</sub>	30x2-30x5 mm
IK.122.25.33	(D1+B)-(D1+D1)-(D2+B)-(D2+D2)-(N+B)-(N+N)	DC-NC 2" <sup>1</sup> / <sub>2</sub>	40x3-40x5 mm
IK.122.30.04	(D1+B)-(D1+D1)-(D2+B)-(D2+D2)-(N+B)-(N+N)	DC-NC 3"	1x50mm <sup>2</sup>
IK.122.30.05	(D1+B)-(D1+D1)-(D2+B)-(D2+D2)-(N+B)-(N+N)	DC-NC 3"	1x70mm <sup>2</sup>
IK.122.30.06	(D1+B)-(D1+D1)-(D2+B)-(D2+D2)-(N+B)-(N+N)	DC-NC 3"	1x95mm <sup>2</sup>
IK.122.30.24	(D1+B)-(D1+D1)-(D2+B)-(D2+D2)-(N+B)-(N+N)	DC-NC 3"	2x50mm <sup>2</sup>
IK.122.30.25	(D1+B)-(D1+D1)-(D2+B)-(D2+D2)-(N+B)-(N+N)	DC-NC 3"	2x70mm <sup>2</sup>
IK.122.30.26	(D1+B)-(D1+D1)-(D2+B)-(D2+D2)-(N+B)-(N+N)	DC-NC 3"	2x95mm <sup>2</sup>
IK.122.30.31	(D1+B)-(D1+D1)-(D2+B)-(D2+D2)-(N+B)-(N+N)	DC-NC 3"	20x3-25x5 mm
IK.122.30.32	(D1+B)-(D1+D1)-(D2+B)-(D2+D2)-(N+B)-(N+N)	DC-NC 3"	30x2-30x5 mm
IK.122.30.33	(D1+B)-(D1+D1)-(D2+B)-(D2+D2)-(N+B)-(N+N)	DC-NC 3"	40x3-40x5 mm

### MAIN MATERIAL

A=Aluminium, B=Copper, D=Iron-Steel, F=Bronze, G=Gray Cast Iron, N=Stainless, P=Plastic, S=Brass

### COATINGS

1=Electrogalvanizing, 2=Hot Dip Galvanizing, 3=Electrodeposited Copper, 4=Electrodeposited Tin, 5=Electrodeposited Chromium-Nickel, 6=Black Insulation, 7=Yellow-Green Insulation

### SCREW NUT

DC=Galvanizing, NC=Stainless, SC=Brass

# LIGHTNING ROD INSTALLATION MATERIALS

## Conductor Holder for Mast, Isolated



Code	Material / Coating	Bolt	Mast Conductor Dia. (inch)	Cross Section
IKP.122.20.24	(D1+ B)-(D2+ B)-(N+ B) (D1+D1)-(D2+D2)-(N+N)	DC-NC	2"	2x50mm <sup>2</sup>
IKP.122.20.25	(D1+ B)-(D2+ B)-(N+ B) (D1+D1)-(D2+D2)-(N+N)	DC-NC	2"	2x70mm <sup>2</sup>
IKP.122.20.26	(D1+ B)-(D2+ B)-(N+ B) (D1+D1)-(D2+D2)-(N+N)	DC-NC	2"	2x95mm <sup>2</sup>
IKP.122.20.31	(D1+ B)-(D2+ B)-(N+ B) (D1+D1)-(D2+D2)-(N+N)	DC-NC	2"	25x3mm
IKP.122.20.32	(D1+ B)-(D2+ B)-(N+ B) (D1+D1)-(D2+D2)-(N+N)	DC-NC	2"	30x3mm
IKP.122.20.33	(D1+ B)-(D2+ B)-(N+ B) (D1+D1)-(D2+D2)-(N+N)	DC-NC	2"	40x3mm
IKP.122.25.24	(D1+ B)-(D2+ B)-(N+ B) (D1+D1)-(D2+D2)-(N+N)	DC-NC	2" <sup>1</sup> / <sub>2</sub>	2x50mm <sup>2</sup>
IKP.122.25.25	(D1+ B)-(D2+ B)-(N+ B) (D1+D1)-(D2+D2)-(N+N)	DC-NC	2" <sup>1</sup> / <sub>2</sub>	2x70mm <sup>2</sup>
IKP.122.25.26	(D1+ B)-(D2+ B)-(N+ B) (D1+D1)-(D2+D2)-(N+N)	DC-NC	2" <sup>1</sup> / <sub>2</sub>	2x95mm <sup>2</sup>
IKP.122.25.31	(D1+ B)-(D2+ B)-(N+ B) (D1+D1)-(D2+D2)-(N+N)	DC-NC	2" <sup>1</sup> / <sub>2</sub>	25x3mm
IKP.122.25.32	(D1+ B)-(D2+ B)-(N+ B) (D1+D1)-(D2+D2)-(N+N)	DC-NC	2" <sup>1</sup> / <sub>2</sub>	30x3mm
IKP.122.30.24	(D1+ B)-(D2+ B)-(N+ B) (D1+D1)-(D2+D2)-(N+N)	DC-NC	3"	2x50mm <sup>2</sup>
IKP.122.30.25	(D1+ B)-(D2+ B)-(N+ B) (D1+D1)-(D2+D2)-(N+N)	DC-NC	3"	2x70mm <sup>2</sup>
IKP.122.30.26	(D1+ B)-(D2+ B)-(N+ B) (D1+D1)-(D2+D2)-(N+N)	DC-NC	3"	2x95mm <sup>2</sup>
IKP.122.30.31	(D1+ B)-(D2+ B)-(N+ B) (D1+D1)-(D2+D2)-(N+N)	DC-NC	3"	25x3mm
IKP.122.30.32	(D1+ B)-(D2+ B)-(N+ B) (D1+D1)-(D2+D2)-(N+N)	DC-NC	3"	30x3mm

**MAIN MATERIAL**

A=Aluminium, B=Copper, D=Iron-Steel,  
F=Bronze, G=Gray Cast Iron,  
N=Stainless, P=Plastic, S=Brass

**COATINGS**

1=Electrogalvanizing, 2=Hot Dip Galvanizing, 3=Electrodeposited Copper,  
4=Electrodeposited Tin, 5=Electrodeposited Chromium-Nickel,  
6=Black Insulation, 7=Yellow-Green Insulation

**SCREW NUT**

DC=Galvanizing,  
NC=Stainless,  
SC=Brass

# LIGHTNING ROD INSTALLATION MATERIALS

## Clamp For Stretch Wire



Code	Material / Coating	Pipe Dia. (inch)
GE.105.05	D1-D2	2"
GE.105.06	D1-D2	2" <sup>1</sup> / <sub>2</sub>
GE.105.07	D1-D2	3"

## Stretch Wire



Code	Material / Coating	Dia.
GE.104.01	D2 - (D2 + P)	Ø6 mm
GE.104.02	D2 - (D2 + P)	Ø8 mm
GE.104.06	D2 - (D2 + P)	Ø10 mm
GE.104.07	D2 - (D2 + P)	Ø12 mm

## Turnbuckle



Code	Material / Coating	Thread Dia.	Leght
GE.101.01	D2	M6	108 mm
GE.101.02	D2	M8	108 mm
GE.101.03	D2	M10	125 mm
GE.101.04	D2	M12	125 mm
GE.101.05	D2	M16	125 mm

# LIGHTNING ROD INSTALLATION MATERIALS

## Stretch Wire Stake

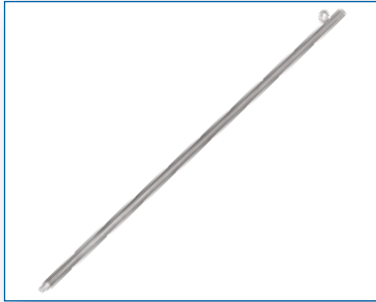

Code	Material / Coating	Leight
GE.102.01	D1-D2-N	Ø16mm - 100cm

## Stretch Wire Clamp



Code	Material / Coating	Wire Dia.
GE.103.01	D2	Ø6 mm
GE.103.02	D2	Ø8 mm
GE.103.03	D2	Ø10 mm
GE.103.04	D2	Ø12 mm

## Cringle



Code	Material / Coating	Dia.
RDN.101.01	D2	Ø6 mm
RDN.101.02	D2	Ø8 mm
RDN.101.03	D2	Ø10 mm
RDN.101.04	D2	Ø12 mm

### MAIN MATERIAL

A=Aluminium, B=Copper, D=Iron-Steel,  
F=Bronze, G=Gray Cast Iron,  
N=Stainless, P=Plastic, S=Brass

### COATINGS

1=Electrogalvanizing, 2=Hot Dip Galvanizing, 3=Electrodeposited Copper,  
4=Electrodeposited Tin, 5=Electrodeposited Chromium-Nickel,  
6=Black Insulation, 7=Yellow-Green Insulation

### SCREW NUT

DC=Galvanizing,  
NC=Stainless,  
SC=Brass

# CLASSICAL METHODS



## MESH METHOD

Protection Level	ROD					Mesh Size (m)	Conductor Distance (m)
	Height (m)	20	30	45	60		
I	Angles	25	x	x	x	5 x 5	10
II		35	25	x	x	10 x 10	15
III		45	35	25	x	15 x 15	20
IV		55	45	35	25	20 x 20	25

**MAIN MATERIAL**  
A=Aluminium, B=Copper, D=Iron-Steel,  
F=Bronze, G=Gray Cast Iron,  
N=Stainless, P=Plastic, S=Brass

**COATINGS**  
1=Electrogalvanizing, 2=Hot Dip Galvanizing, 3=Electrodeposited Copper,  
4=Electrodeposited Tin, 5=Electrodeposited Chromium-Nickel,  
6=Black Insulation, 7=Yellow-Green Insulation

**SCREW NUT**  
DC=Galvanizing,  
NC=Stainless,  
SC=Brass

## MESH METHOD INSTALLATION EQUIPMENTS

### Lightning Rod

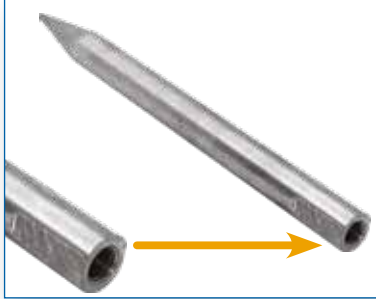

Code	Material / Coating	Dia.	Lenght
FC.416.400	A-B-B5-D1-D2-D5-N	ø16 mm.	400 mm.
FC.416.500	A-B-B5-D1-D2-D5-N	ø16 mm.	500 mm.
FC.416.600	A-B-B5-D1-D2-D5-N	ø16 mm.	600 mm.
FC.416.800	A-B-B5-D1-D2-D5-N	ø16 mm.	800 mm.
FC.420.400	A-B-B5-D1-D2-D5-N	ø20 mm.	400 mm.
FC.420.500	A-B-B5-D1-D2-D5-N	ø20 mm.	500 mm.
FC.420.600	A-B-B5-D1-D2-D5-N	ø20 mm.	600 mm.
FC.420.800	A-B-B5-D1-D2-D5-N	ø20 mm.	800 mm.

### Lightning Rod, Long



Code	Material / Coating	Dia.	Lenght
FC.410.1000	A-B-B5-D1-D2-D5-N	Ø10	1000 mm
FC.416.1000	A-B-B5-D1-D2-D5-N	Ø16	1000 mm
FC.416.1250	A-B-B5-D1-D2-D5-N	Ø16	1250 mm
FC.416.1500	A-B-B5-D1-D2-D5-N	Ø16	1500 mm
FC.416.2000	A-B-B5-D1-D2-D5-N	Ø16	2000 mm
FC.416.3000	A-B-B5-D1-D2-D5-N	Ø16	3000 mm
FC.420.1000	A-B-B5-D1-D2-D5-N	Ø20	1000 mm
FC.420.1250	A-B-B5-D1-D2-D5-N	Ø20	1250 mm
FC.420.1500	A-B-B5-D1-D2-D5-N	Ø20	1500 mm
FC.420.2000	A-B-B5-D1-D2-D5-N	Ø20	2000 mm
FC.420.3000	A-B-B5-D1-D2-D5-N	Ø20	3000 mm

### Lightning Rod "Mushroom Shaped"



Code	Material / Coating
FC.501.01	B5-D5-N

#### MAIN MATERIAL

A=Aluminium, B=Copper, D=Iron-Steel,  
F=Bronze, G=Gray Cast Iron,  
N=Stainless, P=Plastic, S=Brass

#### COATINGS

1=Electrogalvanizing, 2=Hot Dip Galvanizing, 3=Electrodeposited Copper,  
4=Electrodeposited Tin, 5=Electrodeposited Chromium-Nickel,  
6=Black Insulation, 7=Yellow-Green Insulation

#### SCREW NUT

DC=Galvanizing,  
NC=Stainless,  
SC=Brass

## MESH METHOD INSTALLATION EQUIPMENTS

### Lightning Rod With Multiple Points



Code	Material / Coating	Dia.
FC.616.01	S5	16 mm
FC.616.02	S5	20 mm

### Catching Tip "Extension Bar"



Code	Material / Coating	Dia.	Lenght
FYB.16.500	D5 - S5	16 mm	500 mm
FYB.16.1000	D5 - S5	16 mm	1000 mm
FYB.16.1500	D5 - S5	16 mm	1500 mm
FYB.20.500	D5 - S5	20 mm	500 mm
FYB.20.1000	D5 - S5	20 mm	1000 mm
FYB.20.1500	D5 - S5	20 mm	1500 mm

### Lightning Rod with Cadweld Joint



Code	Material / Coating	Dia.	Lenght
ER.116.600	B-B5-D5-N	16 mm	600 mm
ER.116.800	B-B5-D5-N	16 mm	800 mm
ER.120.600	B-B5-D5-N	20 mm	600 mm
ER.120.800	B-B5-D5-N	20 mm	800 mm

### Lightning Rod Holder



Code	Material / Coating	Connection Female
ERB.302.01	D1-D2-N	M12

**MAIN MATERIAL**  
A=Aluminium, B=Copper, D=Iron-Steel,  
F=Bronze, G=Gray Cast Iron,  
N=Stainless, P=Plastic, S=Brass

**COATINGS**  
1=Electrogalvanizing, 2=Hot Dip Galvanizing, 3=Electrodeposited Copper,  
4=Electrodeposited Tin, 5=Electrodeposited Chromium-Nickel,  
6=Black Insulation, 7=Yellow-Green Insulation

**SCREW NUT**  
DC=Galvanizing,  
NC=Stainless,  
SC=Brass

## MESH METHOD INSTALLATION EQUIPMENTS

### Lightning Rod Holder "Slope Adjustable"



Code	Material / Coating
ERB.303.01	D1-D2-N

### Lightning Rod Holder "Concrete"



Code	Material / Coating	Weight
FT.500	C	9270 gr

### Lightning Rod Holder "Rod Diameter Adjustable"

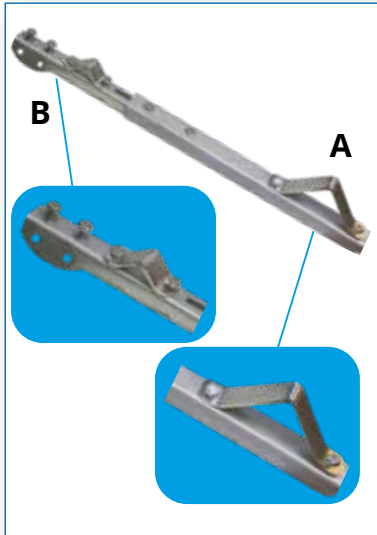

Code	Material / Coating	A- Dia.	B- Rod Dia.
FTS.106.10	D1-D2-N	1" - 3" inç	16 -20 mm

#### MAIN MATERIAL

A=Aluminium, B=Copper, D=Iron-Steel,  
F=Bronze, G=Gray Cast Iron,  
N=Stainless, P=Plastic, S=Brass

#### COATINGS

1=Electrogalvanizing, 2=Hot Dip Galvanizing, 3=Electrodeposited Copper,  
4=Electrodeposited Tin, 5=Electrodeposited Chromium-Nickel,  
6=Black Insulation, 7=Yellow-Green Insulation

#### SCREW NUT

DC=Galvanizing,  
NC=Stainless,  
SC=Brass

# MESH METHOD INSTALLATION EQUIPMENTS

## Lightning Rod Holder for Walls



Code	Material / Coating	Size
FT.502	D1-D2-N	MAX. 100 cm

## Lightning Rod Holder for Walls "Isolated"

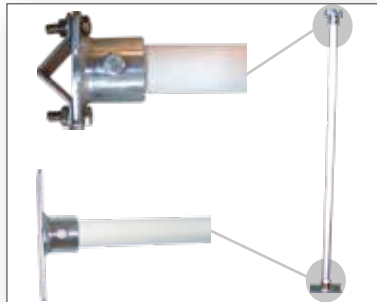

Code	Material / Coating	Length
FT.503	(P+D1) - (P+D2) - (P+N)	MAX. 100 cm

## Lightning Rod Holder "Plus Type"



Code	Material / Coating	Civata Bolt	Cross Section
FT.101.01	S-S4	NC-SC	50 mm <sup>2</sup>
FT.101.02	S-S4	NC-SC	70 mm <sup>2</sup>
FT.101.03	S-S4	NC-SC	95 mm <sup>2</sup>

# MESH METHOD INSTALLATION EQUIPMENTS

## Lightning Rod Holder "Block Type"



Code	Material / Coating	Bolt	Cross Section
FT.103.01	(B+S)-B4+S	NC-SC	50 mm <sup>2</sup>
FT.103.02	(B+S)-B4+S	NC-SC	70 mm <sup>2</sup>

## Base for Plus&Block Type Lightning Rod Holder



Code	Material / Coating	Thread
FTS.103.01	D1-D2-N	M12

## Base for Plus&Block Type Lightning Rod Holder



Code	Material / Coating	Thread
FTS.105.01	D1-D2-N	M12

### MAIN MATERIAL

A=Aluminium, B=Copper, D=Iron-Steel,  
F=Bronze, G=Gray Cast Iron,  
N=Stainless, P=Plastic, S=Brass

### COATINGS

1=Electrogalvanizing, 2=Hot Dip Galvanizing, 3=Electrodeposited Copper,  
4=Electrodeposited Tin, 5=Electrodeposited Chromium-Nickel,  
6=Black Insulation, 7=Yellow-Green Insulation

### SCREW NUT

DC=Galvanizing,  
NC=Stainless,  
SC=Brass

## MESH METHOD INSTALLATION EQUIPMENTS

### Plastic Base for Plus&Block Type Lightning Rod Holder "Can be glued"



Code	Material/Coating	Bolt
IPK.201.01	P	M8

### Lightning Rod Holder "Screw Type"



Code	Material/Coating	Bolt	Cross Section
FT.102.01	(D1+D1)-(D2+A)-(D1+B)-(D2+B)-(N+N)	DC-NC	50 mm <sup>2</sup>
FT.102.02	(D1+D1)-(D2+A)-(D1+B)-(D2+B)-(N+N)	DC-NC	70 mm <sup>2</sup>
FT.102.03	(D1+D1)-(D2+A)-(D1+B)-(D2+B)-(N+N)	DC-NC	95 mm <sup>2</sup>
FT.102.04	(D1+D1)-(D2+A)-(D1+B)-(D2+B)-(N+N)	DC-NC	120mm <sup>2</sup>

### Lightning Rod Holder "Mast Hat"



Code	Material/Coating	Mast Diameter (inch)
FTS.108.01	D1-D2-N	2"
FTS.108.02	D1-D2-N	2.5"
FTS.108.03	D1-D2-N	3"

# MESH METHOD INSTALLATION EQUIPMENTS

## Lightning Rod Holder for Mast Coupling



Code	Material / Coating	Mast Diameter (inch)
FTS.111.01	D1-D2-N	2"
FTS.111.02	D1-D2-N	2 1/2"
FTS.111.03	D1-D2-N	3"

## Lightning Rod Holder For Flat Surfaces



Code	Material / Coating	Bolt	Cond. Size	Thread
FT.201.01	(D1+B)-(D1+D1) (D2+B)-(D2+D2)-(N+N)	DC-NC	50 mm <sup>2</sup>	M12
FT.201.02	(D1+B)-(D1+D1) (D2+B)-(D2+D2)-(N+N)	DC-NC	70 mm <sup>2</sup>	M12
FT.201.03	(D1+B)-(D1+D1) (D2+B)-(D2+D2)-(N+N)	DC-NC	95 mm <sup>2</sup>	M12

## Lightning Rod Holder For Flat Surfaces



Code	Material / Coating	Bolt	Cond. Size	Thread
FT.202.01	(D1+B)-(D1+D1) (D2+B)-(D2+D2)-(N+N)	DC-NC	50 mm <sup>2</sup>	M12
FT.202.02	(D1+B)-(D1+D1) (D2+B)-(D2+D2)-(N+N)	DC-NC	70 mm <sup>2</sup>	M12
FT.202.03	(D1+B)-(D1+D1) (D2+B)-(D2+D2)-(N+N)	DC-NC	95 mm <sup>2</sup>	M12

### MAIN MATERIAL

A=Aluminium, B=Copper, D=Iron-Steel,  
F=Bronze, G=Gray Cast Iron,  
N=Stainless, P=Plastic, S=Brass

### COATINGS

1=Electrogalvanizing, 2=Hot Dip Galvanizing, 3=Electrodeposited Copper,  
4=Electrodeposited Tin, 5=Electrodeposited Chromium-Nickel,  
6=Black Insulation, 7=Yellow-Green Insulation

### SCREW NUT

DC=Galvanizing,  
NC=Stainless,  
SC=Brass

# MESH METHOD INSTALLATION EQUIPMENTS

## Lightning Rod Holder For Flat Surfaces



Code	Material / Coating	Bolt	Cond. Size	Thread
FT.205.01	(D1+B)-(D1+D1) (D2+B)-(D2+D2)-(N+N)	DC-NC	20x3 - 20x5 mm	M12
FT.205.02		DC-NC	25x3 - 25x5 mm	M12
FT.205.03		DC-NC	30x3 - 30x5 mm	M12
FT.205.04		DC-NC	40x3 - 40x5 mm	M12

## Lightning Rod Holder For Flat Surfaces



Code	Material / Coating	Bolt	Cond. Size	Thread
FT.210.01	(D1+F)-(D1+S)-(D2+F) (D2+S)-(N+F)-(N+S)	DC-NC	20x3 mm	M12
FT.210.02	(D1+F)-(D1+S)-(D2+F) (D2+S)-(N+F)-(N+S)	DC-NC	25x3 mm	M12
FT.210.03	(D1+F)-(D1+S)-(D2+F) (D2+S)-(N+F)-(N+S)	DC-NC	30x3 mm	M12

## Lightning Rod Holder "Slope Adjustable"



Code	Material / Coating	Bolt	Cond. Size	Thread
FT.301.01	(D1+B)-(D1+D1) (D2+B)-(D2+D2)-(N+N)	DC-NC	2x50/ 2x70 mm <sup>2</sup>	M12
FT.301.02	(D1+B)-(D1+D1) (D2+B)-(D2+D2)-(N+N)	DC-NC	2x95 mm <sup>2</sup>	
FT.301.03	(D1+B)-(D1+D1) (D2+B)-(D2+D2)-(N+N)	DC-NC	2x120 mm <sup>2</sup>	

# MESH METHOD INSTALLATION EQUIPMENTS

## Lightning Rod Holder "Slope Adjustable"



Code	Material / Coating	Bolt	Cond. Size	Thread
FT.303.01	(D1+B)-(D1+D1) (D2+B)-(D2+D2)-(N+N)	DC-NC	2x50 mm <sup>2</sup> 2x70 mm <sup>2</sup>	M12
FT.303.02	(D1+B)-(D1+D1) (D2+B)-(D2+D2)-(N+N)	DC-NC	2x95 mm <sup>2</sup>	
FT.303.03	(D1+B)-(D1+D1) (D2+B)-(D2+D2)-(N+N)	DC-NC	2x120 mm <sup>2</sup>	

## Lightning Rod Holder "Slope Adjustable"

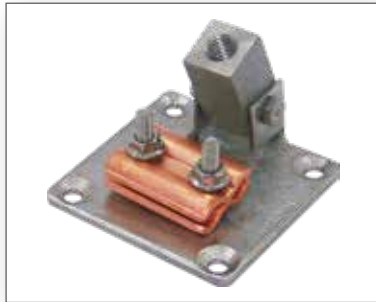

Code	Material / Coating	Bolt	Cond. Size	Thread
FT.306.01	(D1+B)-(D1+D1) (D2+B)-(D2+D2)-(N+N)	DC-NC	2x50 mm <sup>2</sup>	M12
FT.306.02	(D1+B)-(D1+D1) (D2+B)-(D2+D2)-(N+N)	DC-NC	2x70 mm <sup>2</sup>	
FT.306.03	(D1+B)-(D1+D1) (D2+B)-(D2+D2)-(N+N)	DC-NC	2x95 mm <sup>2</sup>	

## Lightning Rod Holder "Slope Adjustable"



Code	Material / Coating	Bolt	Cond. Size	Thread
FT.308.01	(D1+B)-(D1+D1) (D2+B)-(D2+D2)-(N+N)	DC-NC	2x50 mm <sup>2</sup> 2x70 mm <sup>2</sup>	M12
FT.308.02	(D1+B)-(D1+D1) (D2+B)-(D2+D2)-(N+N)	DC-NC	2x95 mm <sup>2</sup>	
FT.308.03	(D1+B)-(D1+D1) (D2+B)-(D2+D2)-(N+N)	DC-NC	2x120 mm <sup>2</sup>	

**MAIN MATERIAL**

A=Aluminium, B=Copper, D=Iron-Steel,  
F=Bronze, G=Gray Cast Iron,  
N=Stainless, P=Plastic, S=Brass

**COATINGS**

1=Electrogalvanizing, 2=Hot Dip Galvanizing, 3=Electrodeposited Copper,  
4=Electrodeposited Tin, 5=Electrodeposited Chromium-Nickel,  
6=Black Insulation, 7=Yellow-Green Insulation

**SCREW NUT**

DC=Galvanizing,  
NC=Stainless,  
SC=Brass

# MESH METHOD INSTALLATION EQUIPMENTS

## Lightning Rod Holder For Walls and Chimneys



Code	Material / Coating	Bolt	Cond. Size	Thread
FT.402.01	(D1+B)-(D2+B)-(D1+D1) (D2+D2)-(N+N)	DC-NC	2x50 mm <sup>2</sup>	M12
FT.402.02	(D1+B)-(D2+B)-(D1+D1) (D2+D2)-(N+N)	DC-NC	2x70 mm <sup>2</sup>	
FT.402.03	(D1+B)-(D2+B)-(D1+D1) (D2+D2)-(N+N)	DC-NC	2x95 mm <sup>2</sup>	

## Lightning Rod Holder For Clamp Roofs



Code	Material / Coating	Bolt	Cond. Size	Thread
FT.307.01	(B+B)-(D1+B)-(D1+D1) (D2+B)-(D2+D2)-(N+N)	DC-NC	2x50 mm <sup>2</sup> 2x70 mm <sup>2</sup>	M12
FT.307.02	(B+B)-(D1+B)-(D1+D1) (D2+B)-(D2+D2)-(N+N)	DC-NC	2x95 mm <sup>2</sup>	M12
FT.307.01	(B+B)-(D1+B)-(D1+D1) (D2+B)-(D2+D2)-(N+N)	DC-NC	2x120 mm <sup>2</sup>	M12

## Lightning Rod Holder For Clamp Roofs



Code	Material / Coating	Bolt	Cross Section
FT.204.01	(D1+A)-(D1+B)-(D2+A)-(D2+B) (D1+D1)-(D2+D2)-(N+N)	DC-NC	2x50 mm <sup>2</sup> 2x70 mm <sup>2</sup>
FT.204.02	(D1+A)-(D1+B)-(D2+A)-(D2+B) (D1+D1)-(D2+D2)-(N+N)	DC-NC	2x95 mm <sup>2</sup>
FT.204.03	(D1+A)-(D1+B)-(D2+A)-(D2+B) (D1+D1)-(D2+D2)-(N+N)	DC-NC	2x120 mm <sup>2</sup>

### MAIN MATERIAL

A=Aluminium, B=Copper, D=Iron-Steel,  
F=Bronze, G=Gray Cast Iron,  
N=Stainless, P=Plastic, S=Brass

### COATINGS

1=Electrogalvanizing, 2=Hot Dip Galvanizing, 3=Electrodeposited Copper,  
4=Electrodeposited Tin, 5=Electrodeposited Chromium-Nickel,  
6=Black Insulation, 7=Yellow-Green Insulation

### SCREW NUT

DC=Galvanizing,  
NC=Stainless,  
SC=Brass

# MESH METHOD INSTALLATION EQUIPMENTS

## Lightning Rod Holder For Roof Ridges



Code	Material / Coating	Bolt	Cross Section
FT-312.01	(D1+A)-(D1+B)-(D2+A) (D2+B)-(D1+D1) (D2+D2)-(N+N)	DC-NC	2x50 mm <sup>2</sup>
FT-312.02		DC-NC	2x70 mm <sup>2</sup>
FT-312.03		DC-NC	2x95 mm <sup>2</sup>
FT-312.04		DC-NC	20x3 mm
FT-312.05		DC-NC	30x3 mm
FT-312.06		DC-NC	40x3 mm

## Lightning Rod Holder For Roof Ridges



Code	Material / Coating	Bolt	Cross Section
FT.207.01	B - D1 - D2 - N	DC-NC	2x50 mm <sup>2</sup>
FT.207.02			2x70 mm <sup>2</sup>
FT.207.03		DC-NC	2x95 mm <sup>2</sup>
	B - D1 - D2 - N	DC-NC	2x120 mm <sup>2</sup>

## Lightning Rod Holder For Roof Tiles



Code	Material / Coating	Bolt	Cross Section
FT.209.01	B - D1 - D2 - N	DC-NC	2x50 mm <sup>2</sup>
FT.209.02			2x70 mm <sup>2</sup>
FT.209.03		DC-NC	2x95 mm <sup>2</sup>
	B - D1 - D2 - N	DC-NC	2x120 mm <sup>2</sup>

**MAIN MATERIAL**

A=Aluminium, B=Copper, D=Iron-Steel,  
F=Bronze, G=Gray Cast Iron,  
N=Stainless, P=Plastic, S=Brass

**COATINGS**

1=Electrogalvanizing, 2=Hot Dip Galvanizing, 3=Electrodeposited Copper,  
4=Electrodeposited Tin, 5=Electrodeposited Chromium-Nickel,  
6=Black Insulation, 7=Yellow-Green Insulation

**SCREW NUT**

DC=Galvanizing,  
NC=Stainless,  
SC=Brass

# MESH METHOD INSTALLATION EQUIPMENTS

## Lightning Rod Holder For Roof Ridges



Code	Material / Coating	Bolt	Thread
FT.206.01	D1 - D2 - N	DC-NC	M12

## Lightning Rod Holder For Roof Ridges "Robust"



Code	Material / Coating	Bolt	Thread
FT.214.01	D1 - D2 - N	DC-NC	M12

## Lightning Rod Holder For Roof Tiles

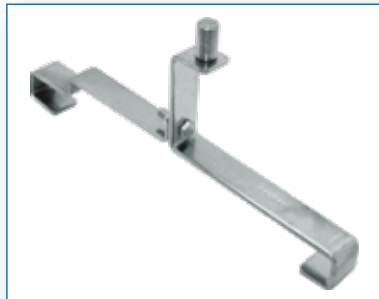

Code	Material / Coating	Bolt	Thread
FT.208.01	D1 - D2 - N	DC-NC	M12

**MAIN MATERIAL**  
 A=Aluminium, B=Copper, D=Iron-Steel,  
 F=Bronze, G=Gray Cast Iron,  
 N=Stainless, P=Plastic, S=Brass

**COATINGS**  
 1=Electrogalvanizing, 2=Hot Dip Galvanizing, 3=Electrodeposited Copper,  
 4=Electrodeposited Tin, 5=Electrodeposited Chromium-Nickel,  
 6=Black Insulation, 7=Yellow-Green Insulation

**SCREW NUT**  
 DC=Galvanizing,  
 NC=Stainless,  
 SC=Brass

## STRETCH WIRE METHOD

### STRETCH WIRE CONDUCTOR METHOD CATENARY WIRES

This is a protected volume creating method defined by rolling sphere and angle method under a stretched conductor. The "s" critical space ( $s=ki.(kc/km)$ ) between the object to be protected and the stretch conductors due to the sagging should be calculated carefully.

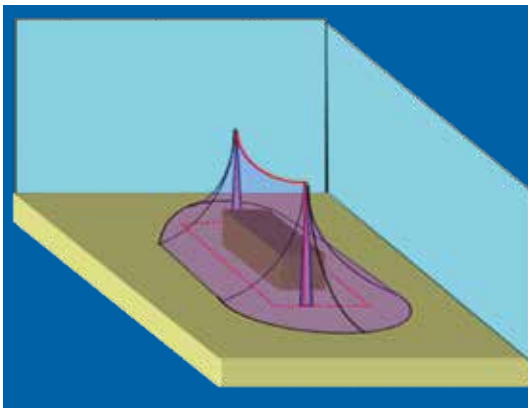

Protection Volume of Stretched Wire Technique

## Stretch Wire Techniques

**A**t the applications which are hard to use air rods, stretch wire technique is preferred for economical and easy applications

SWT is applied to additional devices (cooling and ventilation equipment etc.) on the roofs of large commercial buildings and small warehouses and tanks containing inflammable, detonating or combustible materials.

The Lightning Protection Standard EN/IEC 62305 published in 2006 specifically defines the protection of certain structures by an installation insulated from the building. These structures mainly include the explosive material warehouses.

The application is performed by non-isolated conductors stretched on the Masts having a distance from the structure same as the 'S' separation distance calculated according to the EN/IEC 62305-3/6.3. Similarly, the approximation distance of the wire to the structure should be calculated according to the EN/IEC 62305-3/6.3 by considering the sagging (deflection) of the wire stretched on the structure, and any extension and shortening due to the seasonal temperature differences that may affect this distance should also be taken into account.

Given the uncertainties that may be encountered during the calculation of the "S" separation distance, we can calculate the separation distance by a different approach and examine the result. The different values for the 'k' factors to be used in the calculation of the "S" separation distance can lead us to different conclusions. This causes us to undertake a major risk.

# STRETCH WIRE METHOD

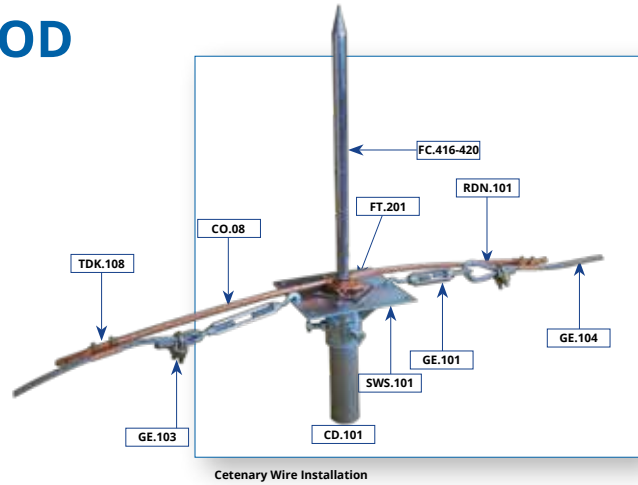

## Mast Cap

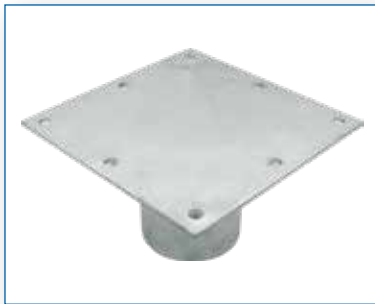

Code	Material / Coating	Dia. (inch)
SWS.101.06	D1-D2-N	2"
SWS.101.07	D1-D2-N	2"½
SWS.101.08	D1-D2-N	3"
SWS.101.09	D1-D2-N	4"
SWS.101.10	D1-D2-N	5"

## Mast



Code	Material / Coating	Dia. (inch)	Length
CD.101.01	D2	½"	6000 mm
CD.101.02	D2	¾"	6000 mm
CD.101.03	D2	1"	6000 mm
CD.101.04	D2	1"¼	6000 mm
CD.101.15	D2	1.5"	6000 mm
CD.101.06	D2	2"	6000 mm
CD.101.07	D2	2"½	6000 mm
CD.101.08	D2	3"	6000 mm
CD.101.09	D2	4"	6000 mm
CD.101.10	D2	5"	6000 mm

## Insulated Mast Clamp



Code	Material / Coating	Bolt	Mast Dia. (inch)	Conductor Cross Section
IKP.122.20.24	(D1+ B)-(D2+ B)-(N+ B) (D1+D1)-(D2+D2)-(N+N)	DC-NC	2	2x50mm <sup>2</sup>
IKP.122.20.25		DC-NC	2	2x70mm <sup>2</sup>
IKP.122.20.26		DC-NC	2	2x95mm <sup>2</sup>
IKP.122.20.31		DC-NC	2	25x3mm
IKP.122.20.32		DC-NC	2	30x3mm
IKP.122.20.33		DC-NC	2	40x3mm
IKP.122.25.24		DC-NC	2"½	2x50mm <sup>2</sup>
IKP.122.25.25		DC-NC	2"½	2x70mm <sup>2</sup>
IKP.122.25.26		DC-NC	2"½	2x95mm <sup>2</sup>
IKP.122.25.31		DC-NC	2"½	25x3mm
IKP.122.25.32		DC-NC	2"½	30x3mm
IKP.122.30.24		DC-NC	3"	2x50mm <sup>2</sup>
IKP.122.30.25		DC-NC	3"	2x70mm <sup>2</sup>
IKP.122.30.26		DC-NC	3"	2x95mm <sup>2</sup>
IKP.122.30.31		DC-NC	3"	25x3mm
IKP.122.30.32		DC-NC	3"	30x3mm

### MAIN MATERIAL

A=Aluminium, B=Copper, D=Iron-Steel, F=Bronze, G=Gray Cast Iron, N=Stainless, P=Plastic, S=Brass

### COATINGS

1=Electrogalvanizing, 2=Hot Dip Galvanizing, 3=Electrodeposited Copper, 4=Electrodeposited Tin, 5=Electrodeposited Chromium-Nickel, 6=Black Insulation, 7=Yellow-Green Insulation

### SCREW NUT

DC=Galvanizing, NC=Stainless, SC=Brass

## STRETCH WIRE METHOD

### Lightning Rod



Code	Material / Coating	Dia.	Lenght
FCL.110.1000	A	10 mm	1000 mm

### Lightning Rod Adapter



Code	Material / Coating	Description
FCA.110.02	A - B4 - D2 - N	Ø50 / 2" /M12 Adaptor
FCA.110.03	A - B4 - D2 - N	Ø50 / ¾" /M12 Adaptor

### Insulated Mast



Code	Material / Coating	Dia.	Lenght
PKB.50.3000	Polyester PVC Kapli	50 mm	3000 mm
PKB.50.4500	PVC Coating Polyester	50 mm	4500 mm

### Concrete Base for Insulated Mast



Code	Material / Coating	Description
PKA.002.01	D2+C - N+C	
PKA.002.02	N - N+C	Ø20

#### MAIN MATERIAL

A=Aluminium, B=Copper, D=Iron-Steel, F=Bronze, G=Gray Cast Iron, N=Stainless, P=Plastic, S=Brass

#### COATINGS

1=Electrogalvanizing, 2=Hot Dip Galvanizing, 3=Electrodeposited Copper, 4=Electrodeposited Tin, 5=Electrodeposited Chromium-Nickel, 6=Black Insulation, 7=Yellow-Green Insulation

#### SCREW NUT

DC=Galvanizing, NC=Stainless, SC=Brass

## STRETCH WIRE METHOD

### Hanger



Code	Material / Coating	Thread	Cross Section
FCA.210.10	D1-D2-N	M10	
FCA.210.100.04	D1-D2-N		50 mm <sup>2</sup>
FCA.210.100.06	D1-D2-N		95 mm <sup>2</sup>

### Aluminium Conductor For Stretch Wire



Code	Material / Coating	Cross Section	Weight (kg/m)
ALS-08.08	A	50 mm <sup>2</sup>	0,137
ALS-08.09	A	70 mm <sup>2</sup>	0,186

### Stranded Aluminium Conductor For Stretch Wire



	Code	Definition	Dia.	Section	Copper Equivalence	Weight (km/kg)
Pure Aluminium	ALO-100.03	Pansy	8,34	42,49 mm <sup>2</sup>	26,72	116,4
	ALO-100.04	Popy	9,36	53,48 mm <sup>2</sup>	33,63	146,4
	ALO-100.05	Aster	10,5	67,14 mm <sup>2</sup>	42,99	184,4
	ALO-100.06	Phlox	11,79	84,91 mm <sup>2</sup>	53,4	232,5
Steel Core Aluminium	ALCO-100.02	Sparrow	8,01	39,19 mm <sup>2</sup>	21,1	135,7
	ALCO-100.03	Robin	9	49,48 mm <sup>2</sup>	26,7	171,4
	ALCO-100.04	Rawen	10,11	62,44 mm <sup>2</sup>	33,7	216,2
	ALCO-100.05	Quail	11,34	78,55 mm <sup>2</sup>	42,3	272.1
	ALCO-100.06	Pigecon	12,75	99,3 mm <sup>2</sup>	53,5	343,9

### Stranded Galvanized Steel Conductor For Stretch Wire



Code	Material Coating	Conductor Size	Cross Section	Wire No x Wire Diameter n (Ea.) x Ø(mm)	(Kg/m)
MH-08.06	D2	8 mm	35 mm <sup>2</sup>	19 x 1,67	0,285
MH-08.08	D2	9,15 mm	50 mm <sup>2</sup>	19 x 1,83	0,395
MH-08.09	D2	11,05 mm	70 mm <sup>2</sup>	19 x 2,21	0,580
MH-08.10	D2	12,6 mm	96 mm <sup>2</sup>	19 x 2,54	0,760

**MAIN MATERIAL**  
A=Aluminium, B=Copper, D=Iron-Steel,  
F=Bronze, G=Gray Cast Iron,  
N=Stainless, P=Plastic, S=Brass









**COATINGS**  
1=Electrogalvanizing, 2=Hot Dip Galvanizing, 3=Electrodeposited Copper,  
4=Electrodeposited Tin, 5=Electrodeposited Chromium-Nickel,  
6=Black Insulation, 7=Yellow-Green Insulation

**SCREW NUT**  
DC=Galvanizing,  
NC=Stainless,  
SC=Brass

# DOWN CONDUCTORS

## CONDUCTORS

The down conductor Casing Material and cross-section selection should be made in accordance with the following standards.

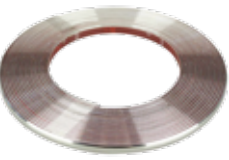
	TS EN 62305 Çizelge 6	TS EN 62561-2	NFC 17-102:2011	
	Bakır	Kalay Kaplı Bakır	Alüminyum	Sıcak daldırılmış galvanizli çelik
Round	50 mm <sup>2</sup>	-	50 mm <sup>2</sup>	
		-		
	CS-101.08		ALS-08.08	GD-101.08
Tressed	50 mm <sup>2</sup> . Her telin çapı en az 1,7mm.			
		-		
	CO-101.08			MH-08.08
Strip	25x2 mm.		25x3	20x2,5
			-	
	CBR-100.08	CBR-100.08.B4		CG.101.08
Coating thickness	-	en az 1 µm.	-	en az 50 µm.

Expansion Piece



Flexible Conductor For Expansion

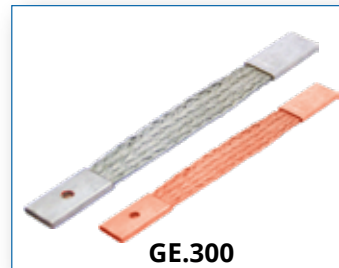

In mesh method applications, seasonal temperature differences cause conductors to lengthen and shorten.

This situation damages the installation. Expansion elements for a healthy and long-lasting installation should be used.

# DOWN CONDUCTORS

## ISOLATED LIGHTNING PROTECTION

### Low Impedance Down Conductor



### AT FIRST GLANCE - LICON™

- ✓ Special insulation suitable for lightning current
- ✓ Very low impedance,
- ✓ High strength
- ✓ Longevity
- ✓ Easy to Apply

### Cable Cross-Section

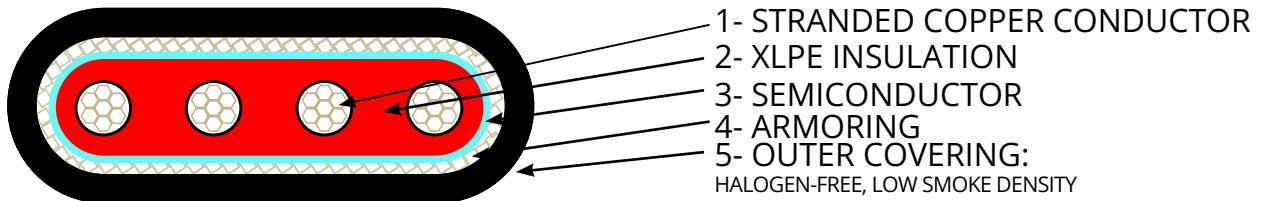

- It is used to minimize the effects of lightning in structures with flammable, explosive and sensitive electronic systems.
- Thanks to its special structure and insulation, it controls the lightning current and does not allow any side-flash effect.
- Thanks to its flat and paintable structure, it prevents visual pollution in buildings.
- Provides ease of installation.

### The Advantage of Licon Cable Impedance

50 m	50 mm <sup>2</sup> (Ω) Copper Conductor	LICON (Ω)	Advantage over 50 mm <sup>2</sup>
Z (50 Hz)	0,03440	0,02940	1,2
Z (100 Hz)	0,06150	0,03250	1,9
Z (500 Hz)	0,29520	0,08560	3,4
Z (1 k Hz)	0,58960	0,16420	3,6
Z (100 k Hz)	58,93620	16,17920	3,6
Z (500 k Hz)	294,68130	80,89600	3,6
Z (1 Mhz)	589,36270	161,79200	3,6
Z (2 Mhz)	1,178,72550	323,58400	3,6

# DOWN CONDUCTORS

## ISOLATED LIGHTNING PROTECTION

### Special Insulated Landing Conductor



- ✓ Special insulation suitable for lightning current
- ✓ High strength
- ✓ Longevity

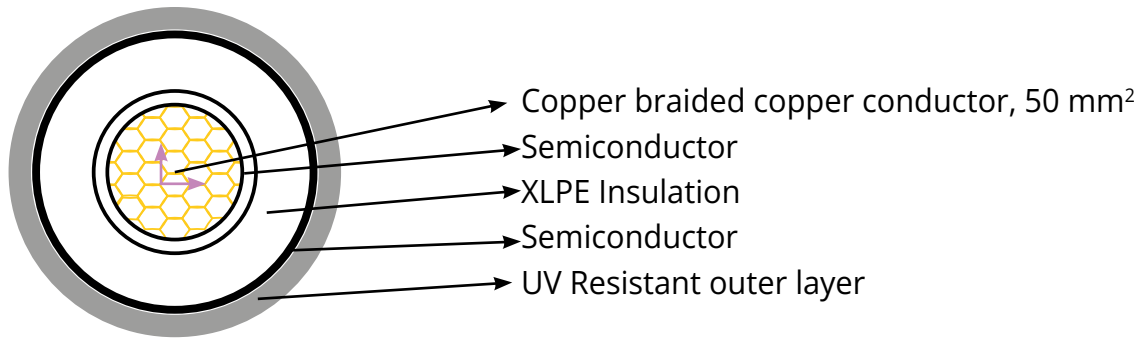

Both conductors were tested with 150 kA according to TS EN 62561.



### Copper Bonded Aluminium Conductor



ALS.08.A3

It is used as an alternative to solid copper or solid aluminum conductors as down conductors.

It is used in the area from the catch terminals to the test terminal.

It is not suitable for use in grounding installations.

#### ADVANTAGES:

- 1. Lightweight:** Lighter than solid copper conductor. Weight: 0.17 kg/m
- 2. Easy to work with:** It is softer than solid copper conductors, making it easier and faster to work with.
- 3. Long-lasting:** The copper coating on the outer surface prevents atmospheric corrosion.
- 4. Economic:** According to Bakır, it is three times lighter and the unit price of the material is much cheaper.

## CABLE CONNECTION TERMINALS

REF NO	DESCRIPTION
TKLF.35.01	Tin Plated Copper Terminal, M10
TKLF.35.02	Tin Plated Copper Terminal, 2 X M10
TKLR.50.01	Stainless Steel M10 - Tin Plated Copper Terminal, M10
TKLR.50.02	Tin Plated Copper Terminal, Ø8 mm
TKLF.201.24	Test Clamp, FLF.35 // 2 x 50 mm <sup>2</sup>



### For FLF.35 Cable

RANK NO	REF NO	DESCRIPTION	BOLT
1	IKFF.113	P+(D1-D2-N-A)	DC-NC
2	IKFF.111	P+(D1-D2-N-A)	DC-NC
3	IKFF.122	P+(D1-D2-N-A)	DC-NC
4	IKFF.109	P+(D1-D2-N-A)	DC-NC
5	IKFF.133	P+(D1-D2-N-A)	DC-NC



### For FLF.50 Cable

RANK NO	REF NO	DESCRIPTION	BOLT
1	IKFR.113	P+(D1-D2-N-A)	DC-NC
2	IKFR.111	P+(D1-D2-N-A)	DC-NC
3	IKFR.122	P+(D1-D2-N-A)	DC-NC
4	IKFR.109	P+(D1-D2-N-A)	DC-NC
5	IKFR.133	P+(D1-D2-N-A)	DC-NC



**MAIN MATERIAL**  
A=Aluminium, B=Copper, D=Iron-Steel,  
F=Bronze, G=Gray Cast Iron,  
N=Stainless, P=Plastic, S=Brass

**COATINGS**  
1=Electrogalvanizing, 2=Hot Dip Galvanizing, 3=Electrodeposited Copper,  
4=Electrodeposited Tin, 5=Electrodeposited Chromium-Nickel,  
6=Black Insulation, 7=Yellow-Green Insulation

**SCREW NUT**  
DC=Galvanizing,  
NC=Stainless,  
SC=Brass

# INSTALLATION EQUIPMENTS

## Single Conductor Clips



Code	Material	Cross-section
IK.101.01	A-B-B4-D1-D2-N	1x16 mm <sup>2</sup>
IK.101.02	A-B-B4-D1-D2-N	1x25 mm <sup>2</sup>
IK.101.03	A-B-B4-D1-D2-N	1x35 mm <sup>2</sup>
IK.101.04	A-B-B4-D1-D2-N	1x50 mm <sup>2</sup>
IK.101.05	A-B-B4-D1-D2-N	1x70 mm <sup>2</sup>
IK.101.06	A-B-B4-D1-D2-N	1x95 mm <sup>2</sup>
IK.101.07	A-B-B4-D1-D2-N	1x120 mm <sup>2</sup>
IK.101.08	A-B-B4-D1-D2-N	1x150 mm <sup>2</sup>
IK.101.09	A-B-B4-D1-D2-N	1x185 mm <sup>2</sup>
IK.101.10	A-B-B4-D1-D2-N	1x240 mm <sup>2</sup>



Code	Material	Cross-section
IK.103.01	A-B-B4-D1-D2-N	1x16 mm <sup>2</sup>
IK.103.02	A-B-B4-D1-D2-N	1x25 mm <sup>2</sup>
IK.103.03	A-B-B4-D1-D2-N	1x35 mm <sup>2</sup>
IK.103.04	A-B-B4-D1-D2-N	1x50 mm <sup>2</sup>
IK.103.05	A-B-B4-D1-D2-N	1x70 mm <sup>2</sup>
IK.103.06	A-B-B4-D1-D2-N	1x95 mm <sup>2</sup>
IK.103.07	A-B-B4-D1-D2-N	1x120 mm <sup>2</sup>
IK.103.08	A-B-B4-D1-D2-N	1x150 mm <sup>2</sup>
IK.103.09	A-B-B4-D1-D2-N	1x185 mm <sup>2</sup>
IK.103.10	A-B-B4-D1-D2-N	1x240 mm <sup>2</sup>



Code	Material	Cross-section
IK.104.01	A-B-B4-D1-D2-N	1x16 mm <sup>2</sup>
IK.104.02	A-B-B4-D1-D2-N	1x25 mm <sup>2</sup>
IK.104.03	A-B-B4-D1-D2-N	1x35 mm <sup>2</sup>
IK.104.04	A-B-B4-D1-D2-N	1x50 mm <sup>2</sup>
IK.104.05	A-B-B4-D1-D2-N	1x70 mm <sup>2</sup>
IK.104.06	A-B-B4-D1-D2-N	1x95 mm <sup>2</sup>
IK.104.07	A-B-B4-D1-D2-N	1x120 mm <sup>2</sup>
IK.104.08	A-B-B4-D1-D2-N	1x150 mm <sup>2</sup>
IK.104.09	A-B-B4-D1-D2-N	1x185 mm <sup>2</sup>
IK.104.10	A-B-B4-D1-D2-N	1x240 mm <sup>2</sup>

**MAIN MATERIAL**

A=Aluminium, B=Copper, D=Iron-Steel,  
F=Bronze, G=Gray Cast Iron,  
N=Stainless, P=Plastic, S=Brass

**COATINGS**

1=Electrogalvanizing, 2=Hot Dip Galvanizing, 3=Electrodeposited Copper,  
4=Electrodeposited Tin, 5=Electrodeposited Chromium-Nickel,  
6=Black Insulation, 7=Yellow-Green Insulation

**SCREW NUT**

DC=Galvanizing,  
NC=Stainless,  
SC=Brass

# INSTALLATION EQUIPMENTS

## Single Conductor Clips

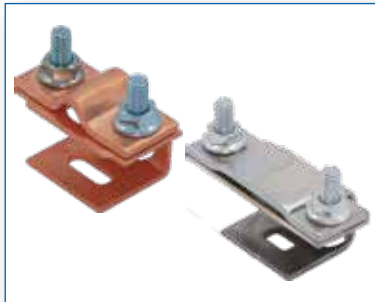

Code	Material	Cross-section	Bolt
IK.109.01	(B+B) (D1+D1) (D2+D2) (N+N)	16mm <sup>2</sup>	DC-NC-SC
IK.109.02		25mm <sup>2</sup>	DC-NC-SC
IK.109.03		35mm <sup>2</sup>	DC-NC-SC
IK.109.04		50mm <sup>2</sup>	DC-NC-SC
IK.109.05		70mm <sup>2</sup>	DC-NC-SC
IK.109.06		95mm <sup>2</sup>	DC-NC-SC
IK.109.07		120mm <sup>2</sup>	DC-NC-SC
IK.109.08		150mm <sup>2</sup>	DC-NC-SC
IK.109.09		185mm <sup>2</sup>	DC-NC-SC
IK.109.10		240mm <sup>2</sup>	DC-NC-SC
IK.109.31		20x3mm - 25x5mm	DC-NC-SC
IK.109.32		30x3mm - 30x5mm	DC-NC-SC
IK.109.33		40x3mm - 40x5mm	DC-NC-SC
IK.109.34		50x3mm - 50x5mm	DC-NC-SC



Code	Material	Cross-section	Bolt
IK.102.00	A-B-B4-D1-D2-N	1x10 mm <sup>2</sup>	DC-NC
IK.102.01		1x16 mm <sup>2</sup>	DC-NC
IK.102.02		1x25 mm <sup>2</sup>	DC-NC
IK.102.03		1x35 mm <sup>2</sup>	DC-NC
IK.102.04		1x50 mm <sup>2</sup>	DC-NC
IK.102.05		1x70 mm <sup>2</sup>	DC-NC
IK.102.06		1x95 mm <sup>2</sup>	DC-NC
IK.102.07		1x120 mm <sup>2</sup>	DC-NC
IK.102.08		1x150 mm <sup>2</sup>	DC-NC
IK.102.09		1x185 mm <sup>2</sup>	DC-NC
IK.102.10		1x240 mm <sup>2</sup>	DC-NC



Code	Material	Cross-section	Bolt
IK.105.31	A-B-B4-D1-D2-N	20x3 - 25x3 mm	DC-NC
IK.105.32		30x3 - 30x5 mm	DC-NC
IK.105.33		40x3 - 40x5 mm	DC-NC
IK.105.34		50x3 - 50x5 mm	DC-NC

# INSTALLATION EQUIPMENTS

## Conductor Clips



Code	Material	Bolt	Cross-section
IK.107.04	(D1+B)-(D1+D1)-(D2+B) (D2+D2)-(N+B)-(N+N)	DC-NC	1x50 <sup>2</sup> mm <sup>2</sup>
IK.107.05	(D1+B)-(D1+D1)-(D2+B) (D2+D2)-(N+B)-(N+N)	DC-NC	1x70 <sup>2</sup> mm <sup>2</sup>
IK.107.06	(D1+B)-(D1+D1)-(D2+B) (D2+D2)-(N+B)-(N+N)	DC-NC	1x95 <sup>2</sup> mm <sup>2</sup>
IK.107.07	(D1+B)-(D1+D1)-(D2+B) (D2+D2)-(N+B)-(N+N)	DC-NC	1x120 <sup>2</sup> mm <sup>2</sup>



Code	Material	Bolt	Cross-section
IK.107.24	(D1+B)-(D1+D1)-(D2+B) (D2+D2)-(N+B)-(N+N)	DC-NC	2x50mm <sup>2</sup>
IK.107.25	(D1+B)-(D1+D1)-(D2+B) (D2+D2)-(N+B)-(N+N)	DC-NC	2x70mm <sup>2</sup>
IK.107.26	(D1+B)-(D1+D1)-(D2+B) (D2+D2)-(N+B)-(N+N)	DC-NC	2x95mm <sup>2</sup>
IK.107.27	(D1+B)-(D1+D1)-(D2+B) (D2+D2)-(N+B)-(N+N)	DC-NC	2x120mm <sup>2</sup>



Code	Material	Bolt	Cross-section
IK.107.31	(D1+B)-(D1+D1)-(D2+B) (D2+D2)-(N+B)-(N+N)	DC-NC	20x3 - 25x5 mm
IK.107.32	(D1+B)-(D1+D1)-(D2+B) (D2+D2)-(N+B)-(N+N)	DC-NC	30x2 - 30x5 mm
IK.107.33	(D1+B)-(D1+D1)-(D2+B) (D2+D2)-(N+B)-(N+N)	DC-NC	40x3 - 40x5 mm

**MAIN MATERIAL**

A=Aluminium, B=Copper, D=Iron-Steel,  
F=Bronze, G=Gray Cast Iron,  
N=Stainless, P=Plastic, S=Brass

**COATINGS**

1=Electrogalvanizing, 2=Hot Dip Galvanizing, 3=Electrodeposited Copper,  
4=Electrodeposited Tin, 5=Electrodeposited Chromium-Nickel,  
6=Black Insulation, 7=Yellow-Green Insulation

**SCREW NUT**

DC=Galvanizing,  
NC=Stainless,  
SC=Brass

# INSTALLATION EQUIPMENTS

## Conductor Clips



Code	Material	Bolt	Cross-section
IK.108.04	(B+D1)-(D1+D1)-(B+D2) (D2+D2)-(N+N)	DC-NC	1x50mm <sup>2</sup>
IK.108.05	(B+D1)-(D1+D1)-(B+D2) (D2+D2)-(N+N)	DC-NC	1x70mm <sup>2</sup>
IK.108.06	(B+D1)-(D1+D1)-(B+D2) (D2+D2)-(N+N)	DC-NC	1x95mm <sup>2</sup>
IK.108.07	(B+D1)-(D1+D1)-(B+D2) (D2+D2)-(N+N)	DC-NC	1x120mm <sup>2</sup>



Code	Material	Bolt	Cross-section
IK.108.24	(B+D1)-(D1+D1)-(B+D2) (D2+D2)-(N+N)	DC-NC	2x50mm <sup>2</sup>
IK.108.25	(B+D1)-(D1+D1)-(B+D2) (D2+D2)-(N+N)	DC-NC	2x70mm <sup>2</sup>
IK.108.26	(B+D1)-(D1+D1)-(B+D2) (D2+D2)-(N+N)	DC-NC	2x95mm <sup>2</sup>
IK.108.27	(B+D1)-(D1+D1)-(B+D2) (D2+D2)-(N+N)	DC-NC	2x120mm <sup>2</sup>



Code	Material	Bolt	Cross-section
IK.108.31	(B+D1)-(D1+D1)-(B+D2) (D2+D2)-(N+N)	DC-NC	20x3-25x5 mm
IK.108.32	(B+D1)-(D1+D1)-(B+D2) (D2+D2)-(N+N)	DC-NC	30x2-30x5 mm
IK.108.33	(B+D1)-(D1+D1)-(B+D2) (D2+D2)-(N+N)	DC-NC	40x3-40x5 mm

**MAIN MATERIAL**  
A=Aluminium, B=Copper, D=Iron-Steel,  
F=Bronze, G=Gray Cast Iron,  
N=Stainless, P=Plastic, S=Brass

**COATINGS**  
1=Electrogalvanizing, 2=Hot Dip Galvanizing, 3=Electrodeposited Copper,  
4=Electrodeposited Tin, 5=Electrodeposited Chromium-Nickel,  
6=Black Insulation, 7=Yellow-Green Insulation

**SCREW NUT**  
DC=Galvanizing,  
NC=Stainless,  
SC=Brass

# INSTALLATION EQUIPMENTS

## Conductor Clips

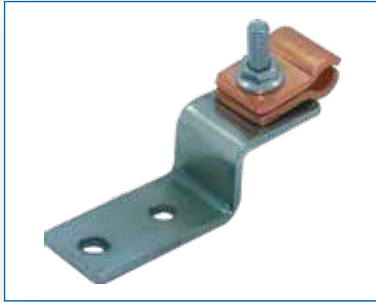

Code	Material	Bolt	Cross-section
IK.111.02	(D1+B)-(D1+D1)-(D2+B) (D2+D2)-(N+B)-(N+N)	DC-NC	1x25mm <sup>2</sup>
IK.111.03	(D1+B)-(D1+D1)-(D2+B) (D2+D2)-(N+B)-(N+N)	DC-NC	1x35mm <sup>2</sup>
IK.111.04	(D1+B)-(D1+D1)-(D2+B) (D2+D2)-(N+B)-(N+N)	DC-NC	1x50mm <sup>2</sup>
IK.111.05	(D1+B)-(D1+D1)-(D2+B) (D2+D2)-(N+B)-(N+N)	DC-NC	1x70mm <sup>2</sup>
IK.111.06	(D1+B)-(D1+D1)-(D2+B) (D2+D2)-(N+B)-(N+N)	DC-NC	1x95mm <sup>2</sup>
IK.111.07	(D1+B)-(D1+D1)-(D2+B) (D2+D2)-(N+B)-(N+N)	DC-NC	1x120mm <sup>2</sup>



Code	Material	Bolt	Cross-section
IK.111.21	(D1+B)-(D1+D1)-(D2+B) (D2+D2)-(N+B)-(N+N)	DC-NC	2x16mm <sup>2</sup>
IK.111.24	(D1+B)-(D1+D1)-(D2+B) (D2+D2)-(N+B)-(N+N)	DC-NC	2x50mm <sup>2</sup>
IK.111.25	(D1+B)-(D1+D1)-(D2+B) (D2+D2)-(N+B)-(N+N)	DC-NC	2x70mm <sup>2</sup>
IK.111.26	(D1+B)-(D1+D1)-(D2+B) (D2+D2)-(N+B)-(N+N)	DC-NC	2x95mm <sup>2</sup>



Code	Material	Bolt	Cross-section
IK.111.31	(D1+B)-(D1+D1)-(D2+B) (D2+D2)-(N+B)-(N+N)	DC-NC	20x3-25x5 mm
IK.111.32	(D1+B)-(D1+D1)-(D2+B) (D2+D2)-(N+B)-(N+N)	DC-NC	30x2-30x5 mm
IK.111.33	(D1+B)-(D1+D1)-(D2+B) (D2+D2)-(N+B)-(N+N)	DC-NC	40x3-40x5 mm

### MAIN MATERIAL

A=Aluminium, B=Copper, D=Iron-Steel,  
F=Bronze, G=Gray Cast Iron,  
N=Stainless, P=Plastic, S=Brass

### COATINGS

1=Electrogalvanizing, 2=Hot Dip Galvanizing, 3=Electrodeposited Copper,  
4=Electrodeposited Tin, 5=Electrodeposited Chromium-Nickel,  
6=Black Insulation, 7=Yellow-Green Insulation

### SCREW NUT

DC=Galvanizing,  
NC=Stainless,  
SC=Brass

# INSTALLATION EQUIPMENTS

## Conductor Clips



Code	Material	Bolt	Cross-section
IK.112.04	(D1+B)-(D1+D1)-(D2+B) (D2+D2)-(N+B)-(N+N)	DC-NC	1x50mm <sup>2</sup>
IK.112.05	(D1+B)-(D1+D1)-(D2+B) (D2+D2)-(N+B)-(N+N)	DC-NC	1x70mm <sup>2</sup>
IK.112.06	(D1+B)-(D1+D1)-(D2+B) (D2+D2)-(N+B)-(N+N)	DC-NC	1x95mm <sup>2</sup>



Code	Material	Bolt	Cross-section
IK.112.24	(D1+B)-(D1+D1)-(D2+B) (D2+D2)-(N+B)-(N+N)	DC-NC	2x50mm <sup>2</sup>
IK.112.25	(D1+B)-(D1+D1)-(D2+B) (D2+D2)-(N+B)-(N+N)	DC-NC	2x70mm <sup>2</sup>
IK.112.26	(D1+B)-(D1+D1)-(D2+B) (D2+D2)-(N+B)-(N+N)	DC-NC	2x95mm <sup>2</sup>



Code	Material	Bolt	Cross-section
IK.112.31	(D1+B)-(D1+D1)-(D2+B) (D2+D2)-(N+B)-(N+N)	DC-NC	20x3-25x3 mm
IK.112.32	(D1+B)-(D1+D1)-(D2+B) (D2+D2)-(N+B)-(N+N)	DC-NC	30x3-30x5 mm
IK.112.33	(D1+B)-(D1+D1)-(D2+B) (D2+D2)-(N+B)-(N+N)	DC-NC	40x3-40x4 mm

**MAIN MATERIAL**  
A=Aluminium, B=Copper, D=Iron-Steel,  
F=Bronze, G=Gray Cast Iron,  
N=Stainless, P=Plastic, S=Brass

**COATINGS**  
1=Electrogalvanizing, 2=Hot Dip Galvanizing, 3=Electrodeposited Copper,  
4=Electrodeposited Tin, 5=Electrodeposited Chromium-Nickel,  
6=Black Insulation, 7=Yellow-Green Insulation

**SCREW NUT**  
DC=Galvanizing,  
NC=Stainless,  
SC=Brass

# INSTALLATION EQUIPMENTS

## Screw Type Conductor Clips



Code	Material	Bolt	Cross-section
IK.113.02	(D1+B)-(D1+D1)-(D2+B) (D2+D2)-(N+B)-(N+N)	DC-NC	1x25mm <sup>2</sup>
IK.113.03	(D1+B)-(D1+D1)-(D2+B) (D2+D2)-(N+B)-(N+N)	DC-NC	1x35mm <sup>2</sup>
IK.113.04	(D1+B)-(D1+D1)-(D2+B) (D2+D2)-(N+B)-(N+N)	DC-NC	1x50mm <sup>2</sup>
IK.113.05	(D1+B)-(D1+D1)-(D2+B) (D2+D2)-(N+B)-(N+N)	DC-NC	1x70mm <sup>2</sup>
IK.113.06	(D1+B)-(D1+D1)-(D2+B) (D2+D2)-(N+B)-(N+N)	DC-NC	1x95mm <sup>2</sup>
IK.113.07	(D1+B)-(D1+D1)-(D2+B) (D2+D2)-(N+B)-(N+N)	DC-NC	1x120mm <sup>2</sup>



Code	Material	Bolt	Cross-section
IK.113.24	(D1+B)-(D1+D1)-(D2+B) (D2+D2)-(N+B)-(N+N)	DC-NC	2x50mm <sup>2</sup>
IK.113.25	(D1+B)-(D1+D1)-(D2+B) (D2+D2)-(N+B)-(N+N)	DC-NC	2x70mm <sup>2</sup>
IK.113.26	(D1+B)-(D1+D1)-(D2+B) (D2+D2)-(N+B)-(N+N)	DC-NC	2x95mm <sup>2</sup>
IK.113.27	(D1+B)-(D1+D1)-(D2+B) (D2+D2)-(N+B)-(N+N)	DC-NC	2x120mm <sup>2</sup>



Kod Code	Casing Material/ Kaplama Material/Coating	Civata Bolt	İletken Kesit Cross Section
IK.113.31	(D1+B)-(D1+D1)-(D2+B) (D2+D2)-(N+B)-(N+N)	DC-NC	20x3-25x5 mm
IK.113.32	(D1+B)-(D1+D1)-(D2+B) (D2+D2)-(N+B)-(N+N)	DC-NC	30x2-30x5 mm
IK.113.33	(D1+B)-(D1+D1)-(D2+B) (D2+D2)-(N+B)-(N+N)	DC-NC	40x3-40x5 mm
IK.113.34	(D1+B)-(D1+D1)-(D2+B) (D2+D2)-(N+B)-(N+N)	DC-NC	50x3-50x5 mm

**MAIN MATERIAL**

A=Aluminium, B=Copper, D=Iron-Steel,  
F=Bronze, G=Gray Cast Iron,  
N=Stainless, P=Plastic, S=Brass

**COATINGS**

1=Electrogalvanizing, 2=Hot Dip Galvanizing, 3=Electrodeposited Copper,  
4=Electrodeposited Tin, 5=Electrodeposited Chromium-Nickel,  
6=Black Insulation, 7=Yellow-Green Insulation

**SCREW NUT**

DC=Galvanizing,  
NC=Stainless,  
SC=Brass

# INSTALLATION EQUIPMENTS

## Insulated Screw Type Conductor Clips



Code	Material	Bolt	Cross-section
IK.115.04	<b>Special Stainless Alloy</b>	DC-NC	1x50mm <sup>2</sup>
IK.115.05		DC-NC	1x70mm <sup>2</sup>
IK.115.06		DC-NC	1x95mm <sup>2</sup>



Code	Material	Bolt	Cross-section
IK.115.24	<b>Special Stainless Alloy</b>	DC-NC	2x50mm <sup>2</sup>
IK.115.25		DC-NC	2x70mm <sup>2</sup>
IK.115.26		DC-NC	2x95mm <sup>2</sup>



Code	Material	Bolt	Cross-section
IK.115.31	<b>Special Stainless Alloy</b>	DC-NC	20x3 - 25x5 mm
IK.115.32		DC-NC	30x2 - 30x5 mm
IK.115.33		DC-NC	40x3 - 40x5 mm

# INSTALLATION EQUIPMENTS

## Conductor Clip For Roof Ridges



Code	Material	Bolt	Cross-section
IK.116.04	(D1+B)-(D1+D1)-(D2+B) (D2+D2)-(N+B)-(N+N)	DC-NC	1x50mm <sup>2</sup>
IK.116.05	(D1+B)-(D1+D1)-(D2+B) (D2+D2)-(N+B)-(N+N)	DC-NC	1x70mm <sup>2</sup>
IK.116.06	(D1+B)-(D1+D1)-(D2+B) (D2+D2)-(N+B)-(N+N)	DC-NC	1x95mm <sup>2</sup>
IK.116.07	(D1+B)-(D1+D1)-(D2+B) (D2+D2)-(N+B)-(N+N)	DC-NC	1x120mm <sup>2</sup>



Code	Material	Bolt	Cross-section
IK.116.24	(D1+B)-(D1+D1)-(D2+B) (D2+D2)-(N+B)-(N+N)	DC-NC	2x50mm <sup>2</sup>
IK.116.25	(D1+B)-(D1+D1)-(D2+B) (D2+D2)-(N+B)-(N+N)	DC-NC	2x70mm <sup>2</sup>
IK.116.26	(D1+B)-(D1+D1)-(D2+B) (D2+D2)-(N+B)-(N+N)	DC-NC	2x95mm <sup>2</sup>



Code	Material	Bolt	Cross-section
IK.116.31	(D1+B)-(D1+D1)-(D2+B) (D2+D2)-(N+B)-(N+N)	DC-NC	20x3-25x5 mm
IK.116.32	(D1+B)-(D1+D1)-(D2+B) (D2+D2)-(N+B)-(N+N)	DC-NC	30x2-30x5 mm
IK.116.33	(D1+B)-(D1+D1)-(D2+B) (D2+D2)-(N+B)-(N+N)	DC-NC	40x3-40x5 mm

**MAIN MATERIAL**

A=Aluminium, B=Copper, D=Iron-Steel,  
F=Bronze, G=Gray Cast Iron,  
N=Stainless, P=Plastic, S=Brass

**COATINGS**

1=Electrogalvanizing, 2=Hot Dip Galvanizing, 3=Electrodeposited Copper,  
4=Electrodeposited Tin, 5=Electrodeposited Chromium-Nickel,  
6=Black Insulation, 7=Yellow-Green Insulation

**SCREW NUT**

DC=Galvanizing,  
NC=Stainless,  
SC=Brass

# INSTALLATION EQUIPMENTS

## Conductor Clip For Roof Ridges



Code	Material	Bolt	Cross-section
IK.117.04	(D1+B)-(D1+D1)-(D2+B) (D2+D2)-(N+B)-(N+N)	DC-NC	1x50mm <sup>2</sup>
IK.117.05	(D1+B)-(D1+D1)-(D2+B) (D2+D2)-(N+B)-(N+N)	DC-NC	1x70mm <sup>2</sup>
IK.117.06	(D1+B)-(D1+D1)-(D2+B) (D2+D2)-(N+B)-(N+N)	DC-NC	1x95mm <sup>2</sup>



Code	Material	Bolt	Cross-section
IK.117.24	(D1+B)-(D1+D1)-(D2+B) (D2+D2)-(N+B)-(N+N)	DC-NC	2x50mm <sup>2</sup>
IK.117.25	(D1+B)-(D1+D1)-(D2+B) (D2+D2)-(N+B)-(N+N)	DC-NC	2x70mm <sup>2</sup>
IK.117.26	(D1+B)-(D1+D1)-(D2+B) (D2+D2)-(N+B)-(N+N)	DC-NC	2x95mm <sup>2</sup>



Code	Material	Bolt	Cross-section
IK.117.31	(D1+B)-(D1+D1)-(D2+B) (D2+D2)-(N+B)-(N+N)	DC-NC	20x3-25x5 mm
IK.117.32	(D1+B)-(D1+D1)-(D2+B) (D2+D2)-(N+B)-(N+N)	DC-NC	30x2-30x5 mm
IK.117.33	(D1+B)-(D1+D1)-(D2+B) (D2+D2)-(N+B)-(N+N)	DC-NC	40x3-40x5 mm

**MAIN MATERIAL**  
A=Aluminium, B=Copper, D=Iron-Steel,  
F=Bronze, G=Gray Cast Iron,  
N=Stainless, P=Plastic, S=Brass

**COATINGS**  
1=Electrogalvanizing, 2=Hot Dip Galvanizing, 3=Electrodeposited Copper,  
4=Electrodeposited Tin, 5=Electrodeposited Chromium-Nickel,  
6=Black Insulation, 7=Yellow-Green Insulation

**SCREW NUT**  
DC=Galvanizing,  
NC=Stainless,  
SC=Brass

# INSTALLATION EQUIPMENTS

## Conductor Clip For Roof Tile



Code	Material	Bolt	Cross-section
IK.118.04	(D1+B)-(D1+D1)-(D2+B) (D2+D2)-(N+B)-(N+N)	DC-NC	1x50mm <sup>2</sup>
IK.118.05	(D1+B)-(D1+D1)-(D2+B) (D2+D2)-(N+B)-(N+N)	DC-NC	1x70mm <sup>2</sup>
IK.118.06	(D1+B)-(D1+D1)-(D2+B) (D2+D2)-(N+B)-(N+N)	DC-NC	1x95mm <sup>2</sup>



Code	Material	Bolt	Cross-section
IK.118.24	(D1+B)-(D1+D1)-(D2+B) (D2+D2)-(N+B)-(N+N)	DC-NC	2x50mm <sup>2</sup>
IK.118.25	(D1+B)-(D1+D1)-(D2+B) (D2+D2)-(N+B)-(N+N)	DC-NC	2x70mm <sup>2</sup>
IK.118.26	(D1+B)-(D1+D1)-(D2+B) (D2+D2)-(N+B)-(N+N)	DC-NC	2x95mm <sup>2</sup>



Code	Material	Bolt	Cross-section
IK.118.31	(D1+B)-(D1+D1)-(D2+B) (D2+D2)-(N+B)-(N+N)	DC-NC	20x3-25x5 mm
IK.118.32	(D1+B)-(D1+D1)-(D2+B) (D2+D2)-(N+B)-(N+N)	DC-NC	30x2-30x5 mm
IK.118.33	(D1+B)-(D1+D1)-(D2+B) (D2+D2)-(N+B)-(N+N)	DC-NC	40x3-40x5 mm

**MAIN MATERIAL**

A=Aluminium, B=Copper, D=Iron-Steel,  
F=Bronze, G=Gray Cast Iron,  
N=Stainless, P=Plastic, S=Brass

**COATINGS**

1=Electrogalvanizing, 2=Hot Dip Galvanizing, 3=Electrodeposited Copper,  
4=Electrodeposited Tin, 5=Electrodeposited Chromium-Nickel,  
6=Black Insulation, 7=Yellow-Green Insulation

**SCREW NUT**

DC=Galvanizing,  
NC=Stainless,  
SC=Brass

# INSTALLATION EQUIPMENTS

## Conductor Clip For Pylons



Code	Material	Bolt	Cross-section
IK.120.04	(D1+B)-(D1+D1)-(D2+B) (D2+D2)-(N+B)-(N+N)	DC-NC	1x50mm <sup>2</sup>
IK.120.05	(D1+B)-(D1+D1)-(D2+B) (D2+D2)-(N+B)-(N+N)	DC-NC	1x70mm <sup>2</sup>
IK.120.06	(D1+B)-(D1+D1)-(D2+B) (D2+D2)-(N+B)-(N+N)	DC-NC	1x95mm <sup>2</sup>



Code	Material	Bolt	Cross-section
IK.120.24	(D1+B)-(D1+D1)-(D2+B) (D2+D2)-(N+B)-(N+N)	DC-NC	2x50mm <sup>2</sup>
IK.120.25	(D1+B)-(D1+D1)-(D2+B) (D2+D2)-(N+B)-(N+N)	DC-NC	2x70mm <sup>2</sup>
IK.120.26	(D1+B)-(D1+D1)-(D2+B) (D2+D2)-(N+B)-(N+N)	DC-NC	2x95mm <sup>2</sup>



Code	Material	Bolt	Cross-section
IK.120.31	(D1+B)-(D1+D1)-(D2+B) (D2+D2)-(N+B)-(N+N)	DC-NC	20x3-25x5 mm
IK.120.32	(D1+B)-(D1+D1)-(D2+B) (D2+D2)-(N+B)-(N+N)	DC-NC	30x2-30x5 mm
IK.120.33	(D1+B)-(D1+D1)-(D2+B) (D2+D2)-(N+B)-(N+N)	DC-NC	40x3-40x5 mm

**MAIN MATERIAL**  
A=Aluminium, B=Copper, D=Iron-Steel,  
F=Bronze, G=Gray Cast Iron,  
N=Stainless, P=Plastic, S=Brass

**COATINGS**  
1=Electrogalvanizing, 2=Hot Dip Galvanizing, 3=Electrodeposited Copper,  
4=Electrodeposited Tin, 5=Electrodeposited Chromium-Nickel,  
6=Black Insulation, 7=Yellow-Green Insulation

**SCREW NUT**  
DC=Galvanizing,  
NC=Stainless,  
SC=Brass

# INSTALLATION EQUIPMENTS

## Conductor Clip For Pylons, Long Offset

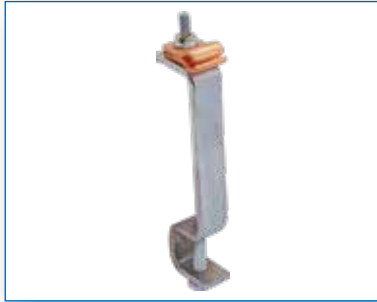

Code	Material	Bolt	Cross-section
IK.121.04	(D1+B)-(D1+D1)-(D2+B) (D2+D2)-(N+B)-(N+N)	DC-NC	1x50mm <sup>2</sup>
IK.121.05	(D1+B)-(D1+D1)-(D2+B) (D2+D2)-(N+B)-(N+N)	DC-NC	1x70mm <sup>2</sup>
IK.121.06	(D1+B)-(D1+D1)-(D2+B) (D2+D2)-(N+B)-(N+N)	DC-NC	1x95mm <sup>2</sup>



Code	Material	Bolt	Cross-section
IK.121.24	(D1+B)-(D1+D1)-(D2+B) (D2+D2)-(N+B)-(N+N)	DC-NC	2x50mm <sup>2</sup>
IK.121.25	(D1+B)-(D1+D1)-(D2+B) (D2+D2)-(N+B)-(N+N)	DC-NC	2x70mm <sup>2</sup>
IK.121.26	(D1+B)-(D1+D1)-(D2+B) (D2+D2)-(N+B)-(N+N)	DC-NC	2x95mm <sup>2</sup>



Code	Material	Bolt	Cross-section
IK.121.31	(D1+B)-(D1+D1)-(D2+B) (D2+D2)-(N+B)-(N+N)	DC-NC	20x3-25x5 mm
IK.121.32	(D1+B)-(D1+D1)-(D2+B) (D2+D2)-(N+B)-(N+N)	DC-NC	30x2-30x5 mm
IK.121.33	(D1+B)-(D1+D1)-(D2+B) (D2+D2)-(N+B)-(N+N)	DC-NC	40x3-40x5 mm

**MAIN MATERIAL**

A=Aluminium, B=Copper, D=Iron-Steel,  
F=Bronze, G=Gray Cast Iron,  
N=Stainless, P=Plastic, S=Brass

**COATINGS**

1=Electrogalvanizing, 2=Hot Dip Galvanizing, 3=Electrodeposited Copper,  
4=Electrodeposited Tin, 5=Electrodeposited Chromium-Nickel,  
6=Black Insulation, 7=Yellow-Green Insulation

**SCREW NUT**

DC=Galvanizing,  
NC=Stainless,  
SC=Brass

# INSTALLATION EQUIPMENTS

## Conductor Clip For Masts



Code	Material / Coated	Bolt Dia.	Cross-Section	
IK.122.20.04		DC-NC 2	1x50mm <sup>2</sup>	
IK.122.20.05		DC-NC 2	1x70mm <sup>2</sup>	
IK.122.20.06		DC-NC 2	1x95mm <sup>2</sup>	
IK.122.20.24		DC-NC 2	2x50mm <sup>2</sup>	
IK.122.20.25		DC-NC 2	2x70mm <sup>2</sup>	
IK.122.20.26		DC-NC 2	2x95mm <sup>2</sup>	
IK.122.20.31		DC-NC 2	20x3-25x5mm	
IK.122.20.32		DC-NC 2	30x2-30x5mm	
IK.122.20.33		DC-NC 2	40x3-40x5mm	
IK.122.25.04		(D1+B)-(D1+D1)-(D2+B) (D2+D2)-(N+B)-(N+N)	DC-NC 2" <sup>1</sup> / <sub>2</sub>	1x50mm <sup>2</sup>
IK.122.25.05			DC-NC 2" <sup>1</sup> / <sub>2</sub>	1x70mm <sup>2</sup>
IK.122.25.06			DC-NC 2" <sup>1</sup> / <sub>2</sub>	1x95mm <sup>2</sup>
IK.122.25.24	DC-NC 2" <sup>1</sup> / <sub>2</sub>		2x50mm <sup>2</sup>	
IK.122.25.25	DC-NC 2" <sup>1</sup> / <sub>2</sub>		2x70mm <sup>2</sup>	
IK.122.25.26	DC-NC 2" <sup>1</sup> / <sub>2</sub>		2x95mm <sup>2</sup>	
IK.122.25.31	DC-NC 2" <sup>1</sup> / <sub>2</sub>		20x3-25x5 mm	
IK.122.25.32	DC-NC 2" <sup>1</sup> / <sub>2</sub>		30x2-30x5mm	
IK.122.25.33	DC-NC 2" <sup>1</sup> / <sub>2</sub>		40x3-40x5mm	
IK.122.30.04			DC-NC 3"	1x50mm <sup>2</sup>
IK.122.30.05			DC-NC 3"	1x70mm <sup>2</sup>
IK.122.30.06			DC-NC 3"	1x95mm <sup>2</sup>
IK.122.30.24		DC-NC 3"	2x50mm <sup>2</sup>	
IK.122.30.25		DC-NC 3"	2x70mm <sup>2</sup>	
IK.122.30.26		DC-NC 3"	2x95mm <sup>2</sup>	
IK.122.30.31		DC-NC 3"	20x3-25x5mm	
IK.122.30.32		DC-NC 3"	30x2-30x5mm	
IK.122.30.33		DC-NC 3"	40x3-40x5mm	

**MAIN MATERIAL**

A=Aluminium, B=Copper, D=Iron-Steel, F=Bronze, G=Gray Cast Iron, N=Stainless, P=Plastic, S=Brass

**COATINGS**

1=Electrogalvanizing, 2=Hot Dip Galvanizing, 3=Electrodeposited Copper, 4=Electrodeposited Tin, 5=Electrodeposited Chromium-Nickel, 6=Black Insulation, 7=Yellow-Green Insulation

**SCREW NUT**

DC=Galvanizing, NC=Stainless, SC=Brass

# INSTALLATION EQUIPMENTS

## Conductor Clip For Clamp Roofs



Code	Material/Coating	Bolt	Cross Section
IK.130.04	(D1+B)-(D1+D1)-(D2+B) (D2+D2)-(N+B)-(N+N)	DC-NC	1x50mm <sup>2</sup>
IK.130.05	(D1+B)-(D1+D1)-(D2+B) (D2+D2)-(N+B)-(N+N)	DC-NC	1x70mm <sup>2</sup>
IK.130.06	(D1+B)-(D1+D1)-(D2+B) (D2+D2)-(N+B)-(N+N)	DC-NC	1x95mm <sup>2</sup>



Code	Material/Coating	Bolt	Cross Section
IK.130.24	(D1+B)-(D1+D1)-(D2+B) (D2+D2)-(N+B)-(N+N)	DC-NC	2x50mm <sup>2</sup>
IK.130.25	(D1+B)-(D1+D1)-(D2+B) (D2+D2)-(N+B)-(N+N)	DC-NC	2x70mm <sup>2</sup>
IK.130.26	(D1+B)-(D1+D1)-(D2+B)- (D2+D2)-(N+B)-(N+N)	DC-NC	2x95mm <sup>2</sup>



Code	Material/Coating	Bolt	Cross Section
IK.130.31	(D1+B)-(D1+D1)-(D2+B) (D2+D2)-(N+B)-(N+N)	DC-NC	20x3-25x5 mm
IK.130.32	(D1+B)-(D1+D1)-(D2+B) (D2+D2)-(N+B)-(N+N)	DC-NC	30x2-30x5 mm
IK.130.33	(D1+B)-(D1+D1)-(D2+B) (D2+D2)-(N+B)-(N+N)	DC-NC	40x3-40x5 mm

**MAIN MATERIAL**

A=Aluminium, B=Copper, D=Iron-Steel,  
F=Bronze, G=Gray Cast Iron,  
N=Stainless, P=Plastic, S=Brass

**COATINGS**

1=Electrogalvanizing, 2=Hot Dip Galvanizing, 3=Electrodeposited Copper,  
4=Electrodeposited Tin, 5=Electrodeposited Chromium-Nickel,  
6=Black Insulation, 7=Yellow-Green Insulation

**SCREW NUT**

DC=Galvanizing,  
NC=Stainless,  
SC=Brass

# INSTALLATION EQUIPMENTS

## Conductor Clip For Clamp Roofs



Code	Material/Coating	Bolt	Cross Section
IK.131.04	(D1+B)-(D1+D1)-(D2+B) (D2+D2)-(N+B)-(N+N)	DC-NC	1x50mm <sup>2</sup>
IK.131.05	(D1+B)-(D1+D1)-(D2+B) (D2+D2)-(N+B)-(N+N)	DC-NC	1x70mm <sup>2</sup>
IK.131.06	(D1+B)-(D1+D1)-(D2+B) (D2+D2)-(N+B)-(N+N)	DC-NC	1x95mm <sup>2</sup>



Code	Material/Coating	Bolt	Cross Section
IK.131.24	(D1+B)-(D1+D1)-(D2+B) (D2+D2)-(N+B)-(N+N)	DC-NC	2x50mm <sup>2</sup>
IK.131.25	(D1+B)-(D1+D1)-(D2+B) (D2+D2)-(N+B)-(N+N)	DC-NC	2x70mm <sup>2</sup>
IK.131.26	(D1+B)-(D1+D1)-(D2+B) (D2+D2)-(N+B)-(N+N)	DC-NC	2x95mm <sup>2</sup>



Code	Material/Coating	Bolt	Cross Section
IK.131.31	(D1+B)-(D1+D1)-(D2+B) (D2+D2)-(N+B)-(N+N)	DC-NC	20x3-25x5 mm
IK.131.32	(D1+B)-(D1+D1)-(D2+B) (D2+D2)-(N+B)-(N+N)	DC-NC	30x2-30x5 mm
IK.131.33	(D1+B)-(D1+D1)-(D2+B) (D2+D2)-(N+B)-(N+N)	DC-NC	40x3-40x5 mm

**MAIN MATERIAL**  
A=Aluminium, B=Copper, D=Iron-Steel,  
F=Bronze, G=Gray Cast Iron,  
N=Stainless, P=Plastic, S=Brass

**COATINGS**  
1=Electrogalvanizing, 2=Hot Dip Galvanizing, 3=Electrodeposited Copper,  
4=Electrodeposited Tin, 5=Electrodeposited Chromium-Nickel,  
6=Black Insulation, 7=Yellow-Green Insulation

**SCREW NUT**  
DC=Galvanizing,  
NC=Stainless,  
SC=Brass

# INSTALLATION EQUIPMENTS

## Conductor Clip For Gutters



Code	Material/Coating	Bolt	Cross Section
IK.133.04	(D1+B)-(D1+D1)-(D2+B) (D2+D2)-(N+B)-(N+N)	DC-NC	1x50mm <sup>2</sup>
IK.133.05	(D1+B)-(D1+D1)-(D2+B) (D2+D2)-(N+B)-(N+N)	DC-NC	1x70mm <sup>2</sup>
IK.133.06	(D1+B)-(D1+D1)-(D2+B) (D2+D2)-(N+B)-(N+N)	DC-NC	1x95mm <sup>2</sup>



Code	Material/Coating	Bolt	Cross Section
IK.133.24	(D1+B)-(D1+D1)-(D2+B) (D2+D2)-(N+B)-(N+N)	DC-NC	2x50mm <sup>2</sup>
IK.133.25	(D1+B)-(D1+D1)-(D2+B) (D2+D2)-(N+B)-(N+N)	DC-NC	2x70mm <sup>2</sup>
IK.133.26	(D1+B)-(D1+D1)-(D2+B) (D2+D2)-(N+B)-(N+N)	DC-NC	2x95mm <sup>2</sup>



Code	Material/Coating	Bolt	Cross Section
IK.133.31	(D1+B)-(D1+D1)-(D2+B) (D2+D2)-(N+B)-(N+N)	DC-NC	20x3-25x5 mm
IK.133.32	(D1+B)-(D1+D1)-(D2+B) (D2+D2)-(N+B)-(N+N)	DC-NC	30x2-30x5 mm
IK.133.33	(D1+B)-(D1+D1)-(D2+B)- (D2+D2)-(N+B)-(N+N)	DC-NC	40x3-40x5 mm

**MAIN MATERIAL**

A=Aluminium, B=Copper, D=Iron-Steel,  
F=Bronze, G=Gray Cast Iron,  
N=Stainless, P=Plastic, S=Brass

**COATINGS**

1=Electrogalvanizing, 2=Hot Dip Galvanizing, 3=Electrodeposited Copper,  
4=Electrodeposited Tin, 5=Electrodeposited Chromium-Nickel,  
6=Black Insulation, 7=Yellow-Green Insulation

**SCREW NUT**

DC=Galvanizing,  
NC=Stainless,  
SC=Brass

# INSTALLATION EQUIPMENTS

## Conductor Clip For Metallic Roofs



Code	Material/Coating	Bolt	Cross Section
IK.134.04	(D1+B)-(D1+D1)-(D2+B) (D2+D2)-(N+B)-(N+N)	DC-NC	1x50mm <sup>2</sup>
IK.134.05	(D1+B)-(D1+D1)-(D2+B) (D2+D2)-(N+B)-(N+N)	DC-NC	1x70mm <sup>2</sup>
IK.134.06	(D1+B)-(D1+D1)-(D2+B) (D2+D2)-(N+B)-(N+N)	DC-NC	1x95mm <sup>2</sup>



Code	Material/Coating	Bolt	Cross Section
IK.134.24	(D1+B)-(D1+D1)-(D2+B) (D2+D2)-(N+B)-(N+N)	DC-NC	2x50mm <sup>2</sup>
IK.134.25	(D1+B)-(D1+D1)-(D2+B) (D2+D2)-(N+B)-(N+N)	DC-NC	2x70mm <sup>2</sup>
IK.134.26	(D1+B)-(D1+D1)-(D2+B) (D2+D2)-(N+B)-(N+N)	DC-NC	2x95mm <sup>2</sup>



Code	Material/Coating	Bolt	Cross Section
IK.134.31	(D1+B)-(D1+D1)-(D2+B) (D2+D2)-(N+B)-(N+N)	DC-NC	20x3-25x5 mm
IK.134.32	(D1+B)-(D1+D1)-(D2+B) (D2+D2)-(N+B)-(N+N)	DC-NC	30x2-30x5 mm
IK.134.33	(D1+B)-(D1+D1)-(D2+B) (D2+D2)-(N+B)-(N+N)	DC-NC	40x3-40x5 mm

**MAIN MATERIAL**  
A=Aluminium, B=Copper, D=Iron-Steel,  
F=Bronze, G=Gray Cast Iron,  
N=Stainless, P=Plastic, S=Brass

**COATINGS**  
1=Electrogalvanizing, 2=Hot Dip Galvanizing, 3=Electrodeposited Copper,  
4=Electrodeposited Tin, 5=Electrodeposited Chromium-Nickel,  
6=Black Insulation, 7=Yellow-Green Insulation

**SCREW NUT**  
DC=Galvanizing,  
NC=Stainless,  
SC=Brass

# INSTALLATION EQUIPMENTS

## Conductor Clip For Metallic Roofs

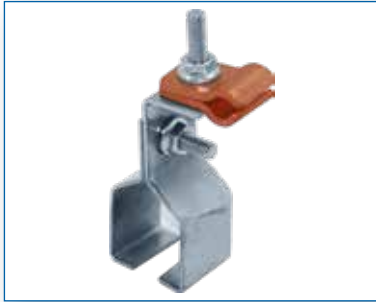

Code	Material/Coating	Bolt	Cross Section
IK.135.04	(D1+B)-(D1+D1)-(D2+B) (D2+D2)-(N+B)-(N+N)	DC-NC	1x50mm <sup>2</sup>
IK.135.05	(D1+B)-(D1+D1)-(D2+B) (D2+D2)-(N+B)-(N+N)	DC-NC	1x70mm <sup>2</sup>
IK.135.06	(D1+B)-(D1+D1)-(D2+B) (D2+D2)-(N+B)-(N+N)	DC-NC	1x95mm <sup>2</sup>



Code	Material/Coating	Bolt	Cross Section
IK.135.24	(D1+B)-(D1+D1)-(D2+B) (D2+D2)-(N+B)-(N+N)	DC-NC	2x50mm <sup>2</sup>
IK.135.25	(D1+B)-(D1+D1)-(D2+B) (D2+D2)-(N+B)-(N+N)	DC-NC	2x70mm <sup>2</sup>
IK.135.26	(D1+B)-(D1+D1)-(D2+B) (D2+D2)-(N+B)-(N+N)	DC-NC	2x95mm <sup>2</sup>



Code	Material/Coating	Bolt	Cross Section
IK.135.31	(D1+B)-(D1+D1)-(D2+B) (D2+D2)-(N+B)-(N+N)	DC-NC	20x3-25x5 mm
IK.135.32	(D1+B)-(D1+D1)-(D2+B) (D2+D2)-(N+B)-(N+N)	DC-NC	30x2-30x5 mm
IK.135.33	(D1+B)-(D1+D1)-(D2+B) (D2+D2)-(N+B)-(N+N)	DC-NC	40x3-40x5 mm

**MAIN MATERIAL**

A=Aluminium, B=Copper, D=Iron-Steel,  
F=Bronze, G=Gray Cast Iron,  
N=Stainless, P=Plastic, S=Brass

**COATINGS**

1=Electrogalvanizing, 2=Hot Dip Galvanizing, 3=Electrodeposited Copper,  
4=Electrodeposited Tin, 5=Electrodeposited Chromium-Nickel,  
6=Black Insulation, 7=Yellow-Green Insulation

**SCREW NUT**

DC=Galvanizing,  
NC=Stainless,  
SC=Brass

# INSTALLATION EQUIPMENTS

## Plastic Clips



Code	Material/Coating	Cross Section
IPK.206.01	P	6-10 mm



Code	Material/Coating	Cross Section
IPK.207.01	P	6-10 mm



Code	Material/Coating	Diameter	Cross Section
IPK.208.01	P	6-10mm	30x3 mm



Code	Material/Coating	Diameter
IPK.210.01	P	2x8 mm
IPK.210.02	P	2x10 mm

**MAIN MATERIAL**  
A=Aluminium, B=Copper, D=Iron-Steel,  
F=Bronze, G=Gray Cast Iron,  
N=Stainless, P=Plastic, S=Brass

**COATINGS**  
1=Electrogalvanizing, 2=Hot Dip Galvanizing, 3=Electrodeposited Copper,  
4=Electrodeposited Tin, 5=Electrodeposited Chromium-Nickel,  
6=Black Insulation, 7=Yellow-Green Insulation

**SCREW NUT**  
DC=Galvanizing,  
NC=Stainless,  
SC=Brass

# INSTALLATION EQUIPMENTS

## Plastic Clips



Code	Material/Coating	Diameter
IPK.211.01	P	1x8 mm
IPK.211.02	P	1x10 mm



Code	Material/Coating	Bolt
IPK.201.01	P	M8



Code	Material/Coating	Cross Section
IPK.301.01	P	1x8 mm
IPK.301.02	(P+C)	1x8 mm
IPK.301.03	P	1x10 mm
IPK.301.04	(P+C)	1x10 mm



Code	Material/Coating	Cross Section
IPK.302.01	(IPK-301.03)+1	20x3 mm
IPK.302.02	(IPK-301.03)+2	25x3 mm
IPK.302.03	(IPK-301.03)+3	30x3 mm
IPK.302.04	(IPK-301.03)+4	30x3.5 mm
IPK.302.05	(IPK-301.03)+5	40x4 mm
IPK.302.06	(IPK-301.03)+6	40x5 mm

**MAIN MATERIAL**

A=Aluminium, B=Copper, D=Iron-Steel,  
F=Bronze, G=Gray Cast Iron,  
N=Stainless, P=Plastic, S=Brass

**COATINGS**

1=Electrogalvanizing, 2=Hot Dip Galvanizing, 3=Electrodeposited Copper,  
4=Electrodeposited Tin, 5=Electrodeposited Chromium-Nickel,  
6=Black Insulation, 7=Yellow-Green Insulation

**SCREW NUT**

DC=Galvanizing,  
NC=Stainless,  
SC=Brass

# INSTALLATION EQUIPMENTS

## Plastic Clips



Code	Material/Coating	Size
IPK.303.00	P	100x100x100 mm
IPK.303.01	P+C	100x100x100 mm



Code	Material/Coating	Cond. Dia	Cross Section
ICK.100.01	P	8 mm	-
ICK.100.02	P+C	10 mm	-
ICK.100.03	P+C	2 mm	2x50mm <sup>2</sup>



Code	Material/Coating	Size
ICK.103.01	P	8 mm
ICK.103.02	P	10 mm



Code	Material/Coating	Cross Section
ICK.104.01	P+C	1x50 mm <sup>2</sup>
ICK.104.02	P+C	1x70 mm <sup>2</sup>
ICK.104.31	P+C	25x3 mm
ICK.104.32	P+C	30X3 mm

**MAIN MATERIAL**  
A=Aluminium, B=Copper, D=Iron-Steel,  
F=Bronze, G=Gray Cast Iron,  
N=Stainless, P=Plastic, S=Brass

**COATINGS**  
1=Electrogalvanizing, 2=Hot Dip Galvanizing, 3=Electrodeposited Copper,  
4=Electrodeposited Tin, 5=Electrodeposited Chromium-Nickel,  
6=Black Insulation, 7=Yellow-Green Insulation

**SCREW NUT**  
DC=Galvanizing,  
NC=Stainless,  
SC=Brass

# INSTALLATION EQUIPMENTS

## Test Clamp

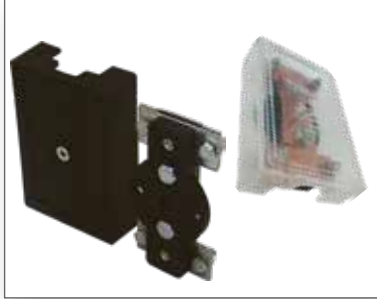

Code	Material/Coating	Bolt	Cross Section
TK.105.04	(P+B)-(P+B4) (P+D1)-(P+D2)-(P+N)	DC-NC	1x50 mm <sup>2</sup>
TK.105.05	(P+B)-(P+B4) (P+D1)-(P+D2)-(P+N)	DC-NC	1x70 mm <sup>2</sup>
TK.105.24	(P+B)-(P+B4) (P+D1)-(P+D2)-(P+N)	DC-NC	2x50 mm <sup>2</sup>
TK.105.25	(P+B)-(P+B4) (P+D1)-(P+D2)-(P+N)	DC-NC	2x70 mm <sup>2</sup>
TK.105.32	(P+B)-(P+B4) (P+D1)-(P+D2)-(P+N)	DC-NC	30x3-30x5 mm



Code	Material/Coating	Cross Section
TK.103.04	B-F-S	1x50 mm <sup>2</sup>
TK.103.05	B-F-S	1x70 mm <sup>2</sup>



Code	Material/Coating	Bolt	Cross Section
TK.104.04	D1-D2-N-S	DC-NC	1x50 mm <sup>2</sup>
TK.104.05	D1-D2-N-S	DC-NC	1x70 mm <sup>2</sup>
TK.104.06	D1-D2-N-S	DC-NC	1x95 mm <sup>2</sup>

**MAIN MATERIAL**

A=Aluminium, B=Copper, D=Iron-Steel,  
F=Bronze, G=Gray Cast Iron,  
N=Stainless, P=Plastic, S=Brass

**COATINGS**

1=Electrogalvanizing, 2=Hot Dip Galvanizing, 3=Electrodeposited Copper,  
4=Electrodeposited Tin, 5=Electrodeposited Chromium-Nickel,  
6=Black Insulation, 7=Yellow-Green Insulation

**SCREW NUT**

DC=Galvanizing,  
NC=Stainless,  
SC=Brass

## INSTALLATION EQUIPMENTS

### Test Clamp



Code	Material/Coating	Bolt	Cross Section
TK.107.04	D1-D2-N-S	DC-NC	1x50 mm <sup>2</sup>
TK.107.05	D1-D2-N-S	DC-NC	1x70 mm <sup>2</sup>
TK.107.06	D1-D2-N-S	DC-NC	1x95 mm <sup>2</sup>



Code	Material/Coating	Bolt	Cross Section
TK.202.24	(D1+B)-(D1+S)-(D1+F) (D2+S)-(D2+F)-(N+S)-(N+F)	DC-NC	2x50 mm <sup>2</sup>
TK.202.25	(D1+B)-(D1+S)-(D1+F) (D2+S)-(D2+F)-(N+S)-(N+F)	DC-NC	2x70 mm <sup>2</sup>
TK.202.26	(D1+B)-(D1+S)-(D1+F) (D2+S)-(D2+F)-(N+S)-(N+F)	DC-NC	2x95 mm <sup>2</sup>
TK.202.31	(D1+B)-(D1+S)-(D1+F) (D2+S)-(D2+F)-(N+S)-(N+F)	DC-NC	20x3-25x5 mm
TK.202.32	(D1+B)-(D1+S)-(D1+F) (D2+S)-(D2+F)-(N+S)-(N+F)	DC-NC	30x3-30x5 mm
TK.202.33	(D1+B)-(D1+S)-(D1+F) (D2+S)-(D2+F)-(N+S)-(N+F)	DC-NC	40x3-40x5 mm

### Protective Tube for Conductor



Code	Material/Coating	Pipe Dia (inch)	Pipe Length
KB.102.01	D1-D2-N	½"	3 m
KB.102.02	D1-D2-N	¾"	3 m
KB.102.03	D1-D2-N	1"	3 m
KB.102.04	D1-D2-N	1" ¼	3 m

# INSTALLATION EQUIPMENTS

## Clamp For Protective Tube



Code	Material / Coating	Pipe Dia. (inch)
CDM.101.05	D1-D2-N	2"
CDM.101.06	D1-D2-N	2"½
CDM.101.07	D1-D2-N	3"

## Equipotential Bonding Piece For Metal Protective Tube



Code	Material/Coating	Pipe Dia
EPT.101.01	A-S-B	¾"
EPT.101.02	A-S-B	1"
EPT.101.03	A-S-B	1" ¼

## Equipotential Bonding Piece For Metal Protective Tube



Code	Material/Coating	Pipe Dia
EPT.102.01	A-S-B	¾"
EPT.102.02	A-S-B	1"
EPT.102.03	A-S-B	1" ¼

**MAIN MATERIAL**

A=Aluminium, B=Copper, D=Iron-Steel, F=Bronze, G=Gray Cast Iron, N=Stainless, P=Plastic, S=Brass

**COATINGS**

1=Electrogalvanizing, 2=Hot Dip Galvanizing, 3=Electrodeposited Copper, 4=Electrodeposited Tin, 5=Electrodeposited Chromium-Nickel, 6=Black Insulation, 7=Yellow-Green Insulation

**SCREW NUT**

DC=Galvanizing, NC=Stainless, SC=Brass