

A.G. PARAFUDR SERIES



All information in this section is provided for technical information purposes.
Radsan may make changes to the products.
This catalog may not be sufficient, especially for the design of advanced systems.
For technical support and updated information, please contact Radsan (444 62 11).

LOCAL DESIGN

DOMESTIC PRODUCTION

SUPERIOR PROTECTION

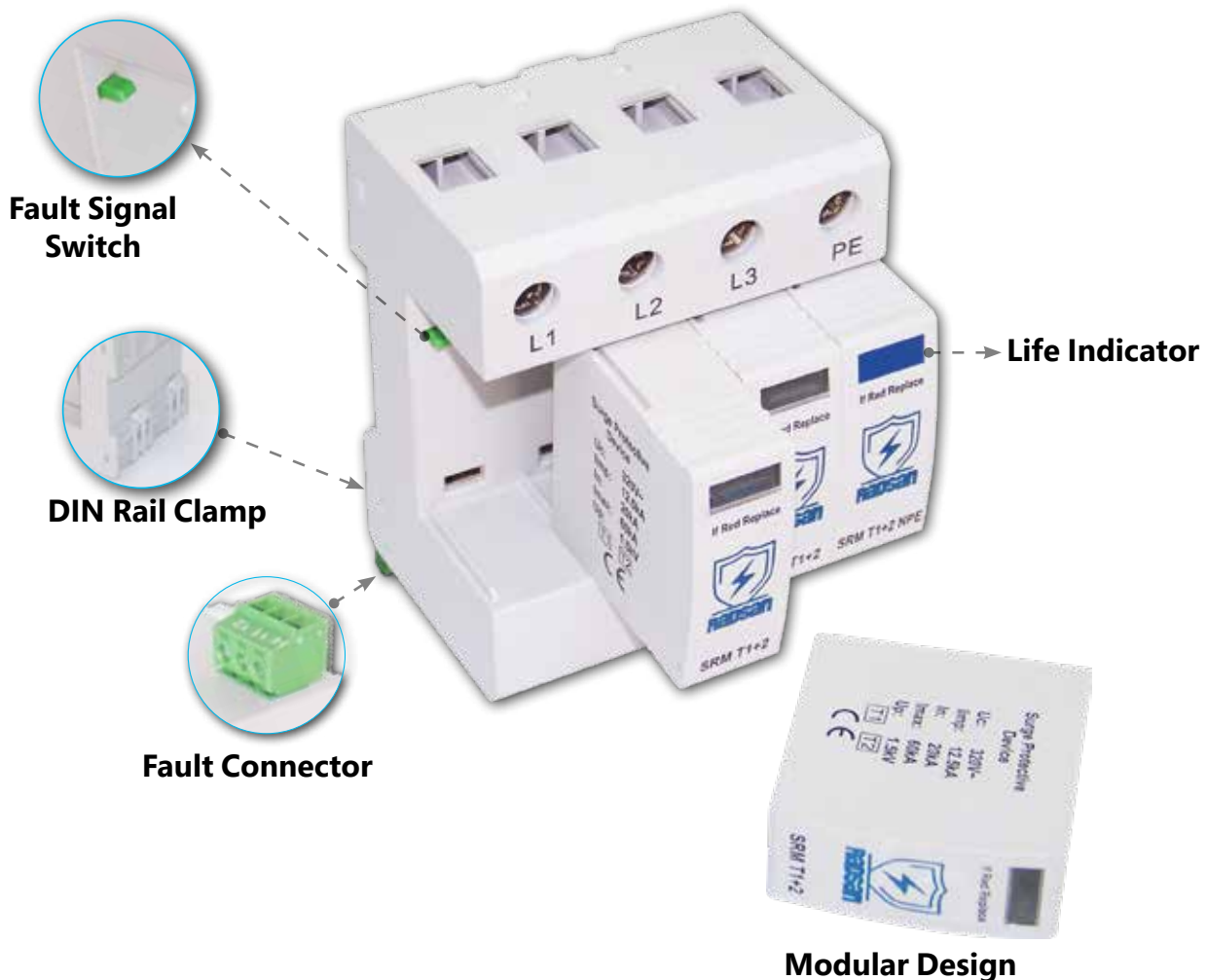

- Modular Design**
- Lifetime Indicator**
- Fault Signal Output**
- Compact Design**
- Space Saving**
- Vibration and Shock Resistance Capacity**
- Easy and Quick Installation**
- Easy Maintenance**
- Compliant with Standards**







LOCAL DESIGN





CERTIFICATES

Domestic Product Certificate

ASO YERLİ MALİ BELGESİ

Belgenin Veriliş Tarihi : 15.10.2021 Belgenin Geçerlilik Tarihi : 15.10.2022 Belge No : 2021107795306
 Çıktısı Çıkmış : RADSAN ELEKTROMEKANİK İNŞAAT ENERJİ MAKİNA TELEKOMÜNİKASYON BİLGİSİM SANAYİ VE TİCARET ANONİM ŞİRKETİ

Şirket Adresi: Hasanoglan Bahçelievler Mahallesi Atatürk Caddesi No:19 ELMADAĞ/ANKARA

Özellikler Vergi Kimlik No: 7340189515 TC Kimlik No: MERSİS No: 0734018951500014

Telefon: 312-8652240 E-posta: radsan@radsan.com.tr
 Faks: 312-8652102 Web Adresi: www.radsan.com.tr

Ticaret Sicil No: 32661 Dye Sicil No: 2391

Ürün Adı: A.G. PARAFUDR TİP 1+2
 Ürün Kodu (PRODCOM/GTIP): 27.12.10.40.00 /
 Teknik Özellikleri/Marka Adı, Modeli, Seri Numarası, Çimli/
 Kapasite Raporunun Tarihi: 12.09.2020 No: 25206 Geçerlilik Süresi: 12.09.2022
 Sanayi Sicil Belgesinin Tarihi: 05.12.2012 No: 502463

Yerli Kalkınma Oranı: % 85,28

Özellikler Teknolojik Düzeyi (düşük/orta-düşük/orta-yüksek/yüksek/Parasit): orta-yüksek

Diğer bilgi ve belgeler:

Bu belge Bilim, Sanayi ve Teknoloji Bakanlığı'nın 13.09.2014 tarih ve 29118 sayılı Resmi Gazetede yayımlanan "Yerli Mali Tebliği (SGM 2014/35)" ne istinaden ve TOBB tarafından hazırlanan "Yerli Mali Belgelerin Düzenlenmesi Uygulama Esaslarına" göre 15.10.2021 tarihinde düzenlenmiştir. Belgenin geçerlilik süresi veriliş tarihinden itibaren bir yıldır geçerlidir.

Düzenleyen Oda/Borsa
 ANKARA SANAYİ ODASI





ASO YERLİ MALİ BELGESİ

Belgenin Veriliş Tarihi : 15.10.2021 Belgenin Geçerlilik Tarihi : 15.10.2022 Belge No : 2021107795307
 Çıktısı Çıkmış : RADSAN ELEKTROMEKANİK İNŞAAT ENERJİ MAKİNA TELEKOMÜNİKASYON BİLGİSİM SANAYİ VE TİCARET ANONİM ŞİRKETİ

Şirket Adresi: Hasanoglan Bahçelievler Mahallesi Atatürk Caddesi No:10 ELMADAĞ/ANKARA

Özellikler Vergi Kimlik No: 7340189515 TC Kimlik No: MERSİS No: 0734018951500014

Telefon: 312-8652240 E-posta: radsan@radsan.com.tr
 Faks: 312-8652102 Web Adresi: www.radsan.com.tr

Ticaret Sicil No: 32661 Dye Sicil No: 2391

Ürün Adı: A.G. PARAFUDR TİP 2
 Ürün Kodu (PRODCOM/GTIP): 27.12.10.40.00 /
 Teknik Özellikleri/Marka Adı, Modeli, Seri Numarası, Çimli/
 Kapasite Raporunun Tarihi: 12.09.2020 No: 25206 Geçerlilik Süresi: 12.09.2022
 Sanayi Sicil Belgesinin Tarihi: 05.12.2012 No: 502463

Yerli Kalkınma Oranı: % 79,30

Özellikler Teknolojik Düzeyi (düşük/orta-düşük/orta-yüksek/yüksek/Parasit): orta-yüksek

Diğer bilgi ve belgeler:

Bu belge Bilim, Sanayi ve Teknoloji Bakanlığı'nın 13.09.2014 tarih ve 29118 sayılı Resmi Gazetede yayımlanan "Yerli Mali Tebliği (SGM 2014/35)" ne istinaden ve TOBB tarafından hazırlanan "Yerli Mali Belgelerin Düzenlenmesi Uygulama Esaslarına" göre 15.10.2021 tarihinde düzenlenmiştir. Belgenin geçerlilik süresi veriliş tarihinden itibaren bir yıldır geçerlidir.

Düzenleyen Oda/Borsa
 ANKARA SANAYİ ODASI





A.G. Parafudr Certificate EN 61643-11:2012

CERTIFICATE
 No. B 107062 0001 Rev. 00

Holder of Certificate: **Radsan Elektromekanik A.Ş.**
 1122 cadde 1434 sokak no:1 incek osk, yeminmahalle
 06378 Ankara
 TÜRKİYE

Production Facility(ies): 080648

Certification Mark: 

Product: **Surge protection equipment (AC SPD)**

Model(s): **SRG T2 1+1, SRG T2 3+1, SRG T2 1P, SRG T2 2P, SRG T2 3P, SRG T2 4P**

Parameters: SPD type: Class II
 Maximum continuous operating voltage Uc: 320VAC
 Max discharge current Imax: 40kA
 Nominal discharge current In: 20kA
 Voltage protection level Up: 1.8kV
 Short circuit withstand Itc: 300A
 Number of ports: One port
 Mounting method: Fixed
 Degree of protection: IP20(after proper installation)
 Temperature range: Extended (-40°C to +70°C)

Tested according to: IEC 61643-11:2011
 EN 61643-11:2012

The product was tested on a voluntary basis and complies with the essential requirements. The certification mark shown above can be affixed on the product. It is not permitted to alter the certification mark in any way. In addition the certification holder must not transfer the certificate to third parties. See also notes overleaf.

Test report no.: 041001804570018
 Valid until: 2023-11-22

Date: 2020-02-11 (Boris Ouyang)

Page 1 of 1
 TÜV SUD Product Service GmbH - Certification Body - Rottenstraße 61 - 80339 Munich - Germany



CERTIFICATE
 No. B 107062 0003 Rev. 00

Holder of Certificate: **Radsan Elektromekanik A.Ş.**
 1122 cadde 1434 sokak no:1 incek osk, yeminmahalle
 06378 Ankara
 TÜRKİYE

Certification Mark: 

Product: **Surge protection equipment
 Surge protective device**

The product was tested on a voluntary basis and complies with the essential requirements. The certification mark shown above can be affixed on the product. It is not permitted to alter the certification mark in any way. In addition the certification holder must not transfer the certificate to third parties. See also notes overleaf.

Test report no.: 701281921401-00
 Valid until: 2021-01-15

Date: 2020-02-19 (Jin Zhu)

Page 1 of 2
 TÜV SUD Product Service GmbH - Certification Body - Rottenstraße 61 - 80339 Munich - Germany



LIFE AND TEMPORARY IMPACTS

Over the past 50 years, rapid advances in technology and developments in electronic systems have significantly increased our daily comfort. Due to the growth of cities, electrical grids have developed and become highly complex. The increasing sensitivity of developing electronic systems and the growing complexity of power supply networks have made electronic systems susceptible to temporary surges. Disruptions in services such as communications, transportation, and healthcare cause significant problems in human life and comfort. Economic consequences are another aspect of the issue. Repair and replacement costs for malfunctioning equipment incur significant expenses. The cost arising from losses such as power outages, data loss, and production system downtime is much higher than the cost of malfunctioning electronic systems.



The need to protect electronic systems against transient surges is constantly increasing. The main reasons for this are:

1. The continuous increase in the use of electronic systems: data centers, computers, servers, etc.
2. Electronic equipment becoming much more sensitive with technological advances
3. The increase in negative factors such as overvoltage, switching, pollution, and noise in large and complex power grids in cities
4. The increase in lightning strikes due to climate change

TRANSIENT SURGES

What are sudden temporary overvoltages (surge voltages)?

Transient overvoltage is a short-term increase in the potential difference (voltage) measured between two or more conductors. In this context, the term "short-term" can range from microseconds (one millionth of a second) to several milliseconds (one thousandth of a second). The increase in voltage can range from a few volts to thousands of volts. For a power supply network, these conductors will be phase, neutral, and ground. For data, communication, and signal lines, these conductors will be lines and ground/shield.

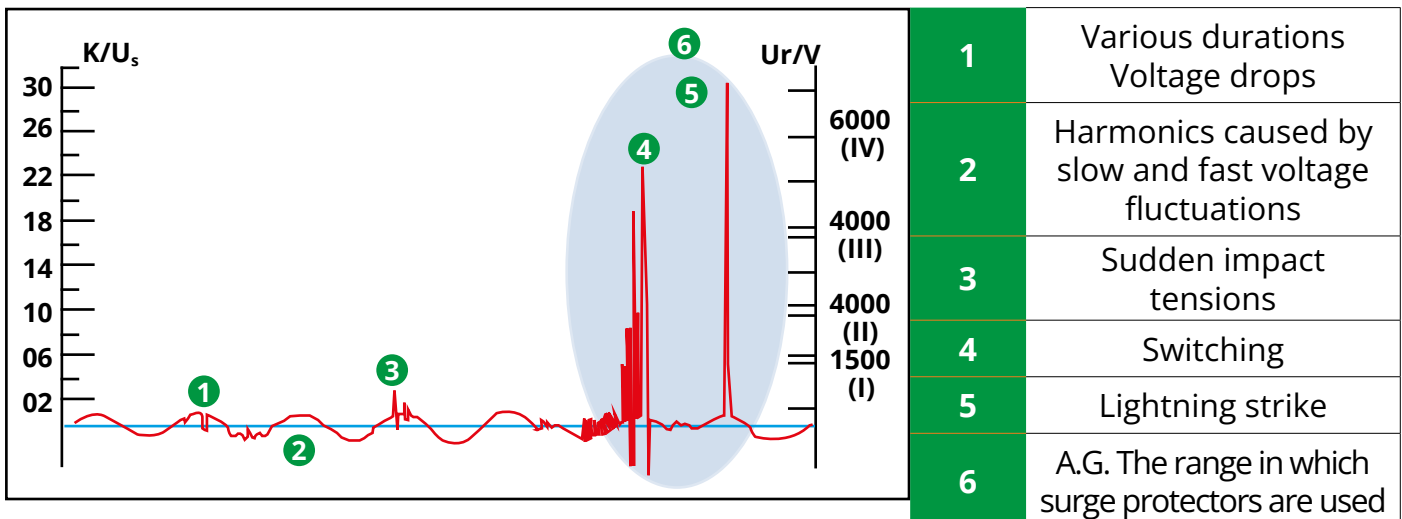

Sources of Transient Overvoltages

Transient overvoltages may occur due to lightning discharges (through resistive, inductive, or capacitive coupling) or as a result of electrical switching operations.

Approximately 35% of all transient overvoltages originate from outside the structure. Typical external sources include lightning, switching operations in the power supply network, electrical faults, and load variations caused by large motors in nearby industrial facilities.

The remaining 65% are generated within buildings and installations, originating from sources such as microwave ovens, laser printers and photocopiers, electric motors, electrical equipment, and even switching devices controlling lighting circuits.

Transient overvoltages caused by lightning and switching phenomena are classified into four distinct categories. Transient overvoltages caused by lightning and switching phenomena are classified into four distinct categories.

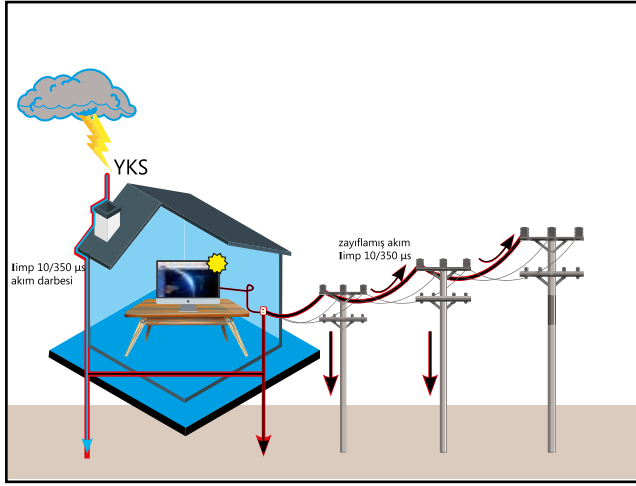

1- Direct Lightning Strike

Lightning is a tremendously powerful, still not fully resolved natural disaster that can reach hundreds of kiloamps, voltage and gigawatts of power. Lightning can cause major damage at the point it falls, but it can also damage an electrical system many kilometers away.

The primary effect of a direct lightning strike is to cause fires in buildings. In buildings equipped with external lightning protection systems, such as lightning rods or cage methods, the risk of fire is greatly reduced. Contrary to popular belief, external lightning protection systems do

not protect electrical systems. The second effect is the damage it causes to electrical systems. In our country's electrical systems, the potential difference between phases and ground is generally 220 V. Neutral and grounding are reference points at 0 volts. When lightning strikes a structure, the current flows to the ground and the electrical grid. Due to the resistance in the PE, the voltage in the PE conductor rises to thousands of volts, creating a large potential difference. This potential difference easily breaks the insulation between the equipment and the grid and ground. Thus, the lightning current flows through the equipment, causing it to malfunction.

2- Havai Hatlara Düşen Yıldırımın Yapıyı Etkilemesi

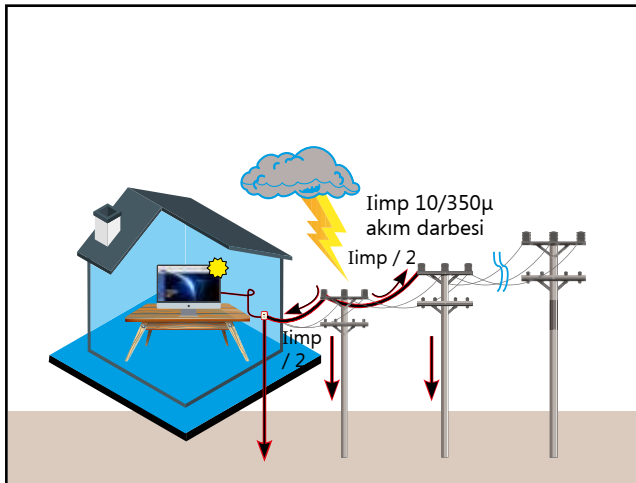

When lightning strikes the lines surrounding the structure and supplying it, the lightning current flows through the line to the structure and causes excessive voltage.

3- Indirect Lightning Strikes (Electromagnetic Effect)

The powerful electromagnetic field of lightning can cause excessive voltage in electrical systems. Similarly, lightning striking an external lightning protection system creates a surge in the closed circuits inside the building. It causes less damage than other sources, but highly sensitive electronic systems such as data lines can be affected by electromagnetic interference.

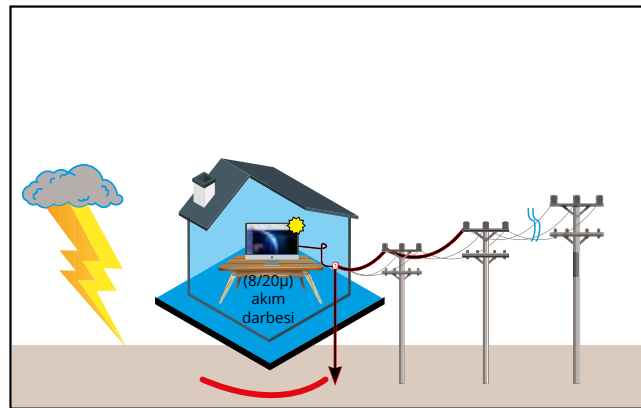
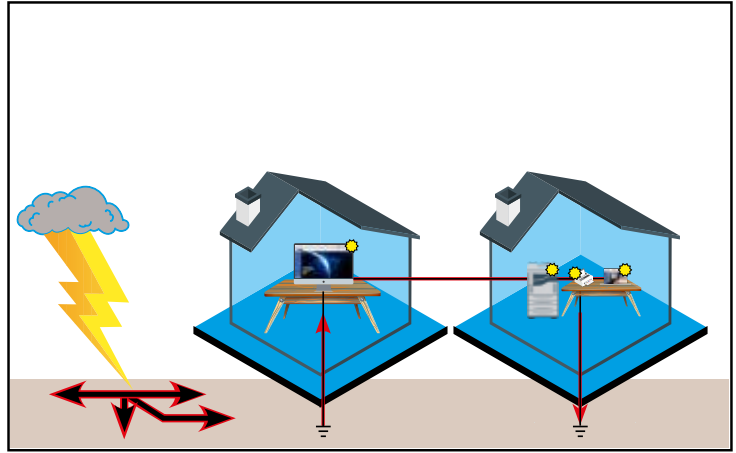
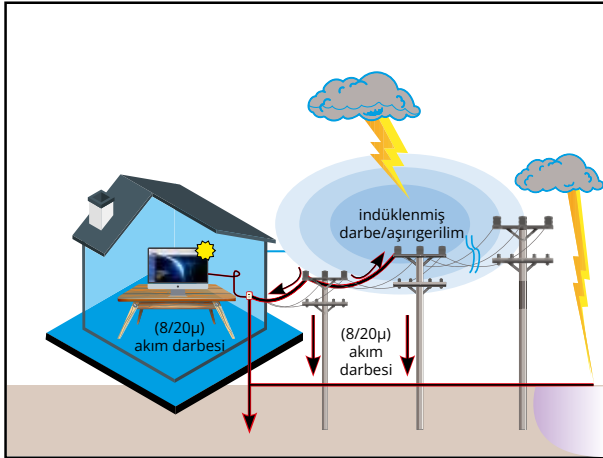

4- Switching

Switching operations occur frequently in almost every location where electrical energy is present. Therefore, transient overvoltages caused by switching events are very common and can be a significant source of interference. Current flowing through a conductor creates a magnetic field in which energy is stored. When the current is interrupted or turned off, the energy in the magnetic field is suddenly released, causing a high voltage transition. Switching equipment such as motors, transformers, arc furnaces, and welding equipment, as well as inductive loads during sudden load changes, cause sudden current changes, resulting in transient voltage surges.

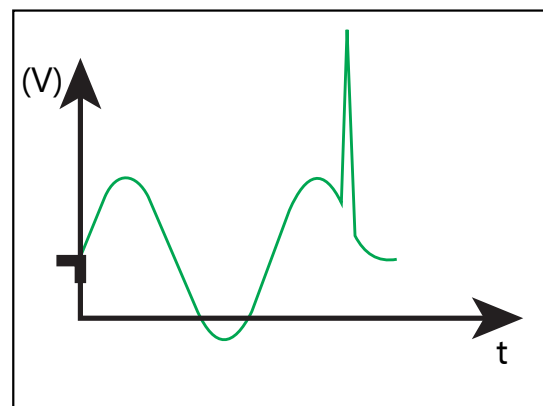
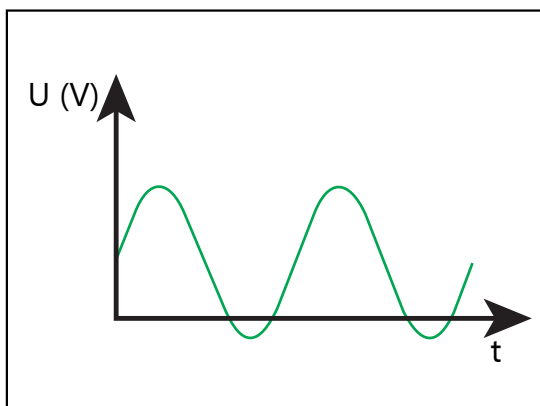

Current Pulses Wave Shapes

Standards such as the IEC EN 61643 series define the characteristics of lightning currents and voltages for testing A.G. surge arresters. These waveforms, determined through years of observation, measurement, and analysis, represent real events most accurately.

Transient waveforms have a rapidly rising edge and a longer tail. They are defined by their peak values, rise time, and decay time.

The following surge waveforms are common current and voltage waveforms used to test surge arresters for use in power, signal, and telecommunication lines.

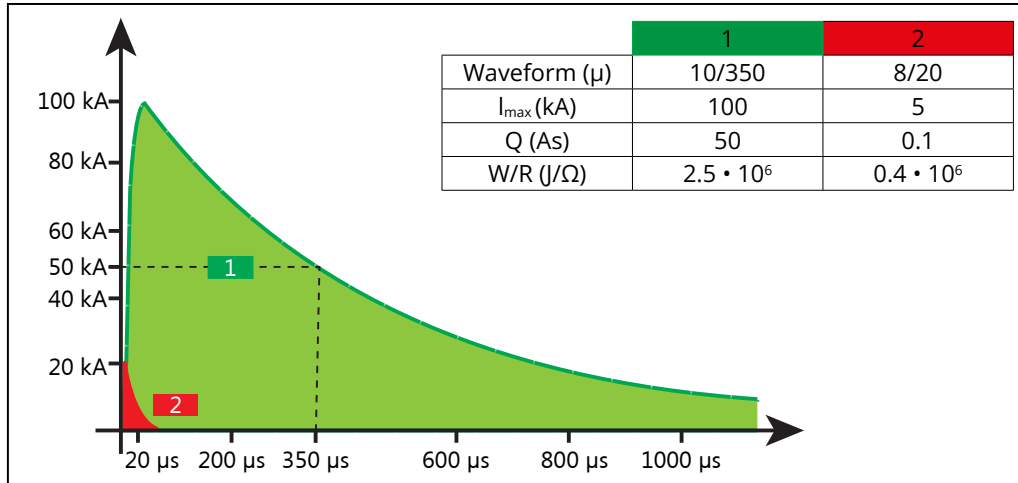

	Ascent time (from 10% to 90% of the highest value)	Peak Current	Half-life
10/350μs wave	10 μs	$I_{imp} = 100$ kA	350μs
8/20μs wave	8 μs	I_n or $I_{max} = 40$ kA	20μs

PRECAUTIONS REQUIRED TO PROTECT FROM TEMPORARY IMPACT

There are several techniques that can be used to minimize the lightning threat to electronic systems. Applying all of them, rather than using them as alternatives, will increase the chance of success.

IEC EN 62305-4 describes a range of measures to minimize the severity of transient overvoltages resulting from lightning and electrical switching:

- Grounding and making equipotential connections
- Electromagnetic shielding and line routing should be done
- Coordinated A.G. surge arrester application
- Improving lightning protection system
- Use of fiber optic cable (with insulation protection)

Protection of equipment against temporary overvoltages relies on the use of A.G. surge arresters and essentially consists of the following:

- Protecting equipment by grounding harmful energy
- Keeping the overvoltage coming to the equipment at a level compatible with the equipment
- Minimizing the effects of induction created by electromagnetic fields resulting from the flow of lightning currents

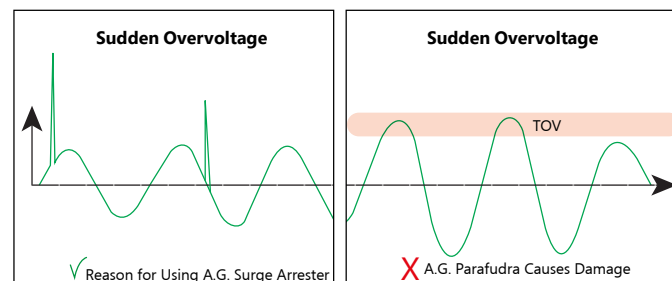

A.G. PARAFUDR HOW IT WORKS

Low voltage surge arresters are specifically designed to protect electrical systems and equipment from transient surges. Using components like varistors and GDTs, they both discharge the load and limit overvoltage to match the surge withstand voltage of the equipment they protect.

The operating principle of the A.G. surge arrester can be compared to that of a circuit breaker:

- In normal use (no overvoltage): Similar to an open circuit breaker. Active lines are isolated from ground.
- When there is an overvoltage, it becomes active by lowering its impedance within a few nanoseconds.

It discharges the lightning current to the ground by working like a closed circuit (circuit breaker closed).

- When the overvoltage is discharged, it automatically returns to its normal impedance (the circuit breaker is open).

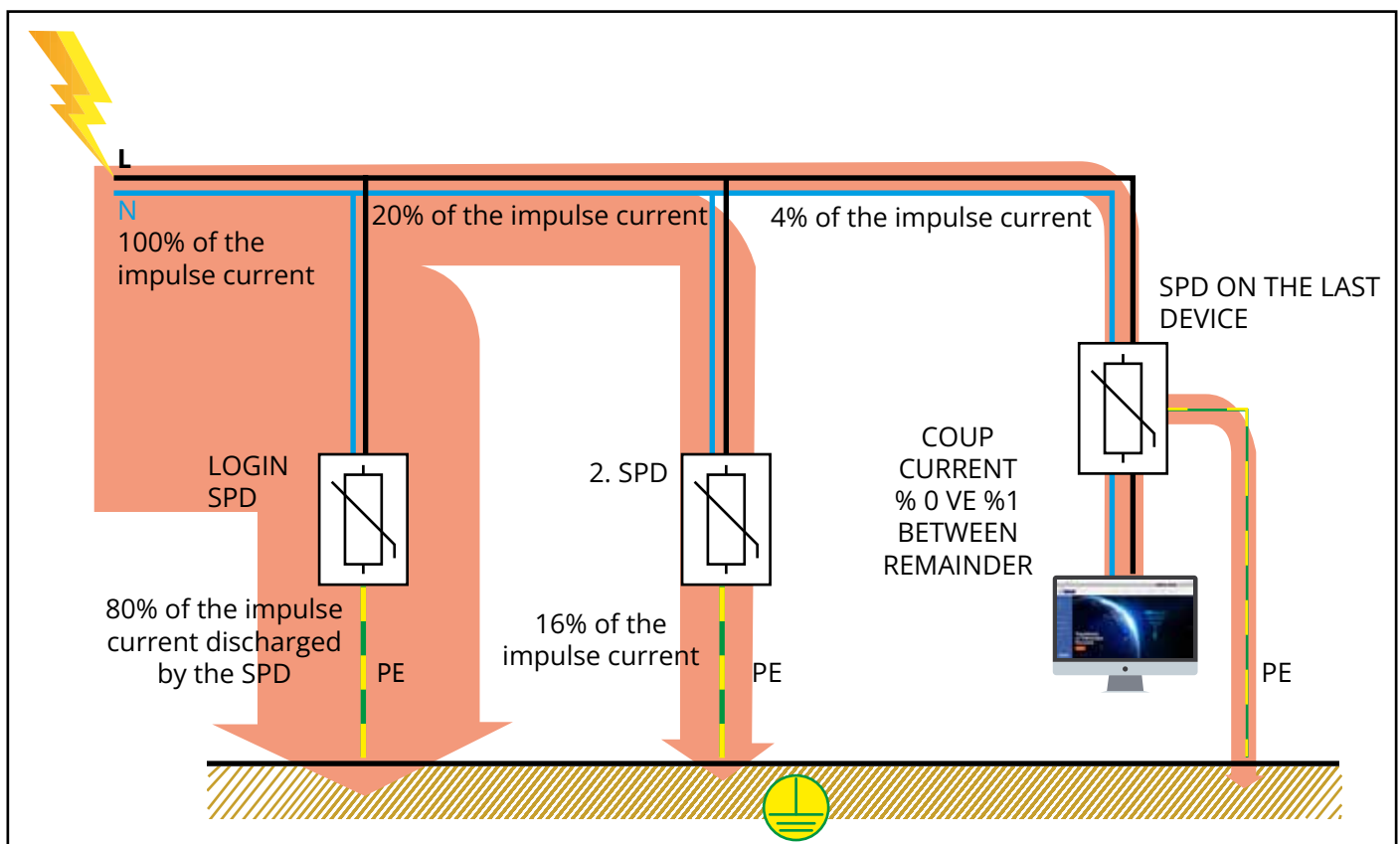
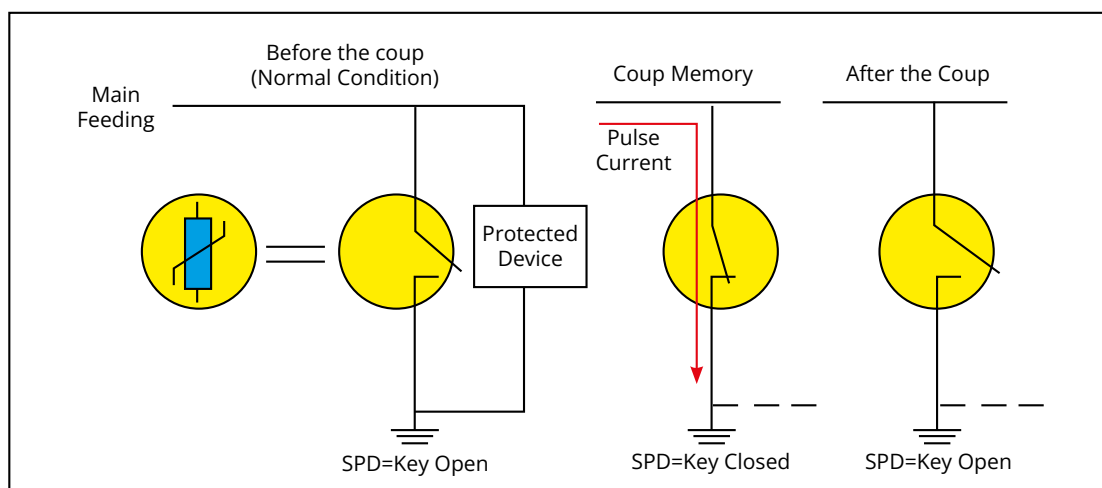

A.G. PARAFUDR VARIETIES

In general, A.G. surge protectors are divided into two classes: low-current power systems and data surge protectors.

For Power Systems A.G. Parafudrlar

1. Type 1 A.G. Surge Arresters are used to protect against direct lightning strikes due to their ability to divert large amounts of energy. They have a high lightning energy discharge capacity. They are tested with a discharge current having a 10/350 μ s waveform.

2. Type 1+2 A.G. Surge protectors are used to protect sensitive equipment at the system's input. They have the ability to divert large amounts of energy directly caused by lightning strikes and the sensitivity to protect electrical equipment directly supplied from the main panel from indirect lightning effects.

3. Type 2 A.G. Surge protectors provide protection against indirect lightning strikes. They protect by providing very fast and high protection against multiple discharges. They should be installed near the equipment to be protected. They are tested with a discharge current having an 8/20 μ s waveform.

Type 3 A.G. Surge Arresters are used to protect sensitive electronic devices. They are tested with a discharge current having a combined waveform (voltage 1.2/50 μ s; current 8/20 μ s).

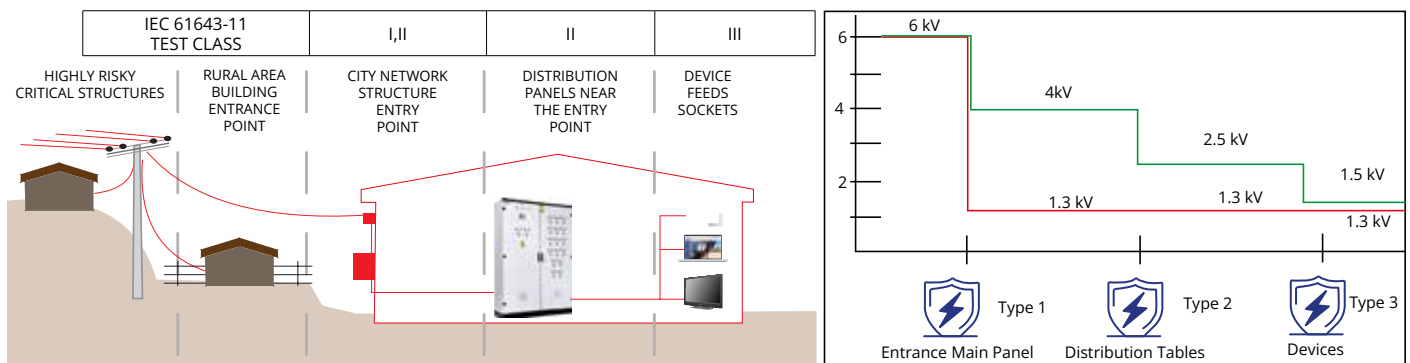

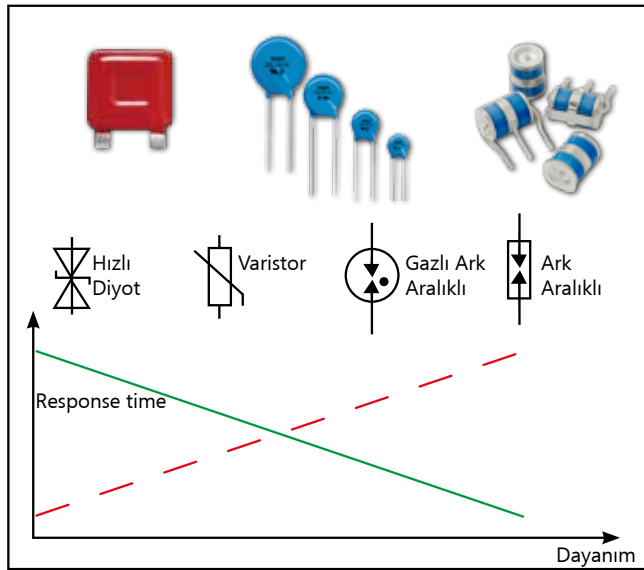

	Type 1	Type 1+2	Type 2	Type 3
Usage Area	To protect against overvoltages caused directly by lightning	For protection against direct and indirect lightning strikes	To protect against indirect lightning overvoltages and impacts caused by switching effects.	To protect sensitive equipment from indirect lightning and switching effects
Structure	Usually spark gaps or GDTs	Generalities varistor+spark gap	Usually varistors or varistor+spark gap	Varistors usually and diodes
Installation Location	The system is inserted into the panel.	It is installed if you have sensitive equipment at the entrance of the system.	It is installed in all electrical panels that supply power to sensitive equipment in the building.	Attached to the panel, end-use point (socket) or equipment.
Tests	10/350 μ s wave in the form with blows	Both 10/350 μ s and 8/20 μ s with pulses in waveform	With 8/20 μ s waveform pulses	voltage 1.2/50 μ s and current 8/20 μ s with pulses in the form of

A.G PARAFUDRDA TECHNOLOGIES USED

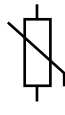
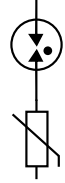
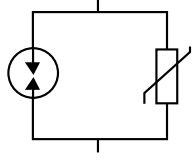
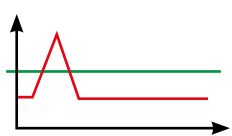
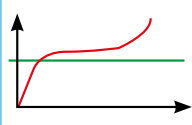
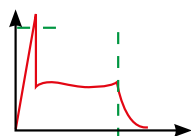
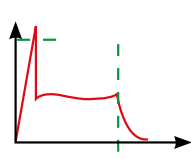
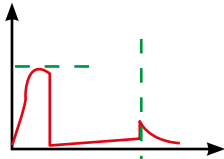

An A.G. surge arrester contains at least one non-linear component. The electrical resistance of this component varies depending on the voltage applied to it. Four types of components are typically used in the Radsan surge arrester group. Since each component has different advantages and disadvantages, combined-hybrid surge arresters have been developed by combining the advantages of both technologies to achieve the best results.

	GAS ARC INTERMITTENT	SPARK GAP	VARISTOR	SERIAL GDT & VARISTOR	PARALLEL GDT & VARISTOR
SYMBOL					
WORK MODE	VOLTAGE SWITCHING	VOLTAGE SWITCHING	VOLTAGE LIMITATION	VOLTAGE SWITCHING AND LIMITING	VOLTAGE SWITCHING AND LIMITING
WORK CURVE					
APPLICATION	TELECOM CORPORATION NETWORK	A.G. ŞEBEKE	A.G. NETWORK	A.G. NETWORK	A.G. NETWORK
PARAFUDR	TYPE 1 or TYPE 2	TYPE 1	TYPE 1 or TYPE 2	TYPE 1+TYPE 2	TYPE 1+TYPE 2

Spark Gap Used In A.G. Parafudrlar

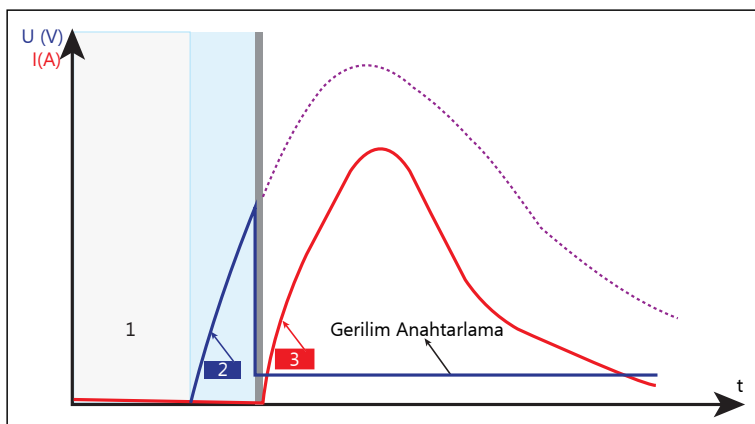

These are switching-class low-voltage surge arresters, designed to protect against high-amplitude surges and operating using the spark gap principle. They can easily withstand strong surges, but due to their somewhat long response times, they cannot protect against low-amplitude, weak surges. They are designed for the first stage of overvoltage protection.

The Spark gap consists of two specially positioned electrodes isolated from the external environment in closed capsules and from each other up to a certain voltage level. (1) Under normal conditions, no current flows between the two

electrodes due to Decoupling. e Spark gap consists of two specially positioned electrodes isolated from the external environment in closed capsules and from each other up to a certain voltage level. (1) Under normal conditions, e Spark gap consists of two specially positioned electrodes isolated from the external environment in closed capsules and from each other up to a certain voltage level. (1) Under normal conditions, no current flows between the two electrodes due to Decoupling. (2) During the pulse, the impedance of the spark gap Decelerates very quickly (100 Dec) to $0.1-1 \Omega$ due to the electric arc formed between the electrodes, and (3) current flows between the electrodes. When the impact ends, the arc is dampened and insulation begins again. The shape, materials and distance between the electrodes characterize the behavior of the arc gap, determining the protection level, discharge capability and other characteristics.

Gas Filled Arc Spaced Protectors (GDT)

They act as high-resistance insulators thanks to their gas-filled, closed capsule and arc. They are typically manufactured as closed capsules with metal electrodes on both sides and a cylindrical ceramic housing. They are typically filled with an inert gas mixture under low pressure. They have a short response time and high discharge damping capacity up to $I_{imp} = 100 \text{ kA}$ (10/350). They have small specific capacitances (very low pF) and high insulation resistances ($>1000 \text{ M}\Omega$). Gas discharge tubes have a long life and high stability.

Varistor Used A.G. Parafudrlar

Its name is derived from the combination of the English words "Variable resistor".

Varistors are voltage-dependent resistors. Because their impedance is controlled by voltage, surge arresters using varistors are called voltage-limiting surge arresters and have high impedance (greater than $1 \text{ M}\Omega$) in the absence of a pulse. These products have low resistance to high-amplitude pulses but a fast response time of ns. They are typically composed of 90% ZnO and 10% additives.

When an overvoltage occurs, the varistor's resistance (impedance) drops very quickly (in a few nanoseconds) to below 1Ω , allowing most of the current to be grounded. Once the surge dissipates, the varistor is isolated again and returns to normal operation.

An important feature of varistors is that a negligible amount of current always flows through them. This current is called leakage current, $I_{PE} = 100-200 \mu\text{A}$.

Silikon Bileşenlere Sahip Koruyucuları (Zener Diyotlar, Tristör, vb.)

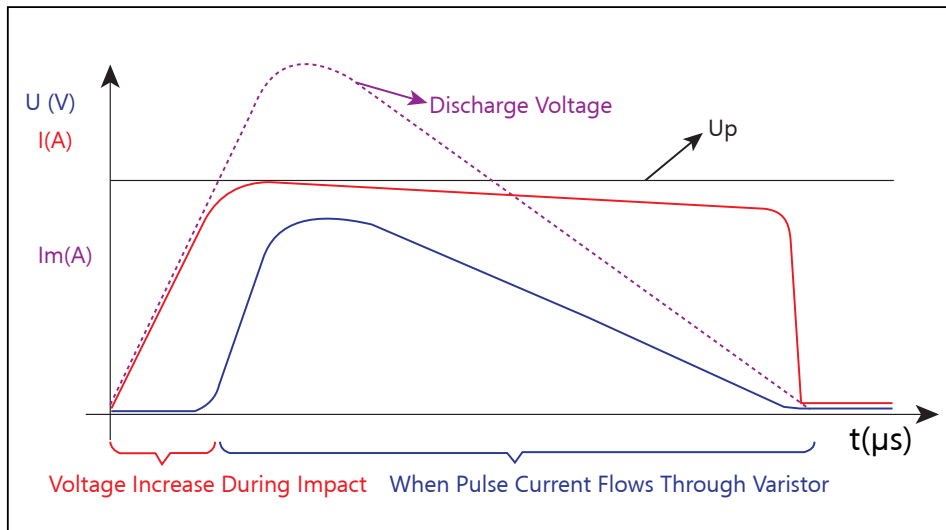

These diodes, thanks to their small size, short response time, and low protection level, are extremely suitable for protecting sensitive electronic circuits in data and telecommunications systems. They are used in low-voltage lines or electronic devices, but their discharge capacity is limited. They provide excellent protection when used in addition to varistor surge suppressors.

Comparison of Spark Gap and Varistors

	Varistor	Spark Gap / GDT	Diode
Power Capacity	It is less powerful than a spark gap. It provides protection against weaker pulses.	It is more powerful than a varistor. It provides protection against stronger surges.	It is less powerful than a varistor.
Reaction Time	Very fast, a few nanoseconds	It is usually slow but can be accelerated with an electronic device.	Very fast, a few nanoseconds
Type of Surge Arrester Used	Typically Type 1+2, Type 2, Type 3	Typically Type 1, Type 1+2, Type 2 neutral	Data surge arresters
Voltage Limiting	Low	High	Low
Service Life	The insulation efficiency constantly decreases. Also, every impact it is exposed to reduces its lifespan.	It has no lifespan. It becomes an open circuit until permanent damage occurs.	There is no service life.

A.G. PARAFUDR THE CHOICE

The correct selection and application of A.G. surge protectors requires first determining the characteristics of the structure or system to be protected. Once the structure to be protected has been defined, the technical specifications of the A.G. surge protectors to be used must be determined.

1- General Principles

- Power surge arresters should be used in power systems and data surge arresters should be used in data systems.

- **Power Systems:** Type 1 surge arresters are preferred in panels that may be affected by direct lightning strikes, Type 2 surge arresters are preferred in panels that may be affected by indirect lightning strikes or switching, and Type 3 surge arresters are preferred in device feeds.

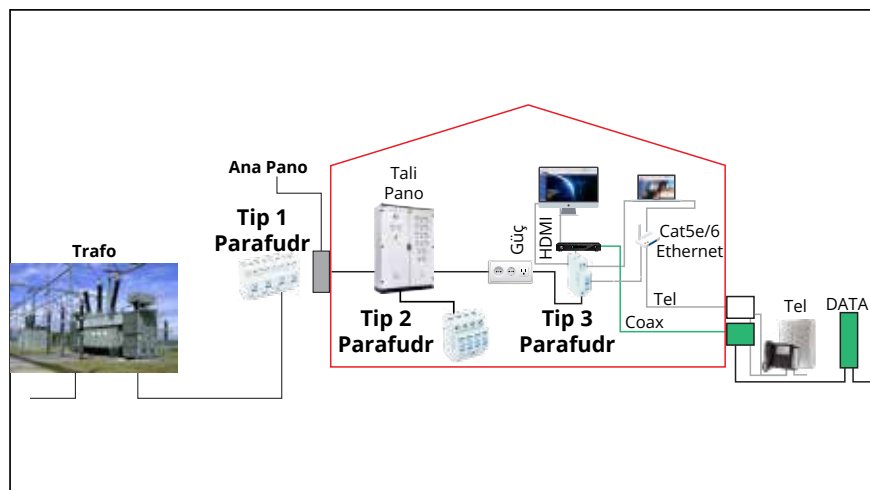

- **Data Systems:** relevant data surge arresters are used for systems such as automation, communication, cameras, sensors, etc.

cameras, sensors, etc.

When protecting a building's electrical system, the first level of protection is achieved by installing a Type 1 class low voltage surge arrester on the main panel at the system entrance. Due to the impact on wiring and the types of surges, additional precautions are necessary. For the second level of protection, Type 2 low voltage surge arresters are used in sub-panels. The third level of protection for sensitive equipment such as computers and TVs is Type 3 low voltage surge

arresters. Type 1+2 surge arresters can be used if a device is powered from the main panel, and Type 2+3 surge arresters can be used if a sensitive device is powered from the sub-panel.

Since data systems, in addition to A.G. power systems, will also be affected by overvoltage, these systems must be protected with appropriate data A.G. surge arresters.

2- Technical Specifications of the Structure to be Protected

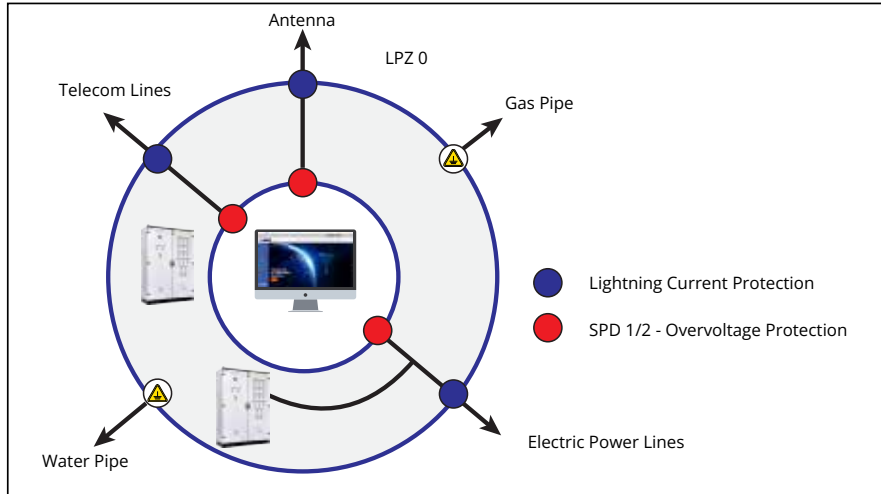

Protection Zones

Surge protection begins at the feed point of the electrical system within the structure and ends at the most sensitive equipment. Discharge energy is reduced by the first stage, with more durable T1 surge arresters, and the second stage,

with more sensitive surge arresters such as T2 and T3. According to standards, the structure is divided into sections based on lightning protection measures, and "Protection Zones" are defined. These sections are determined by measures such as the lightning protection system, armoring, and the use of low voltage surge arresters.

According to the IEC 62305-1 standard, zones are:

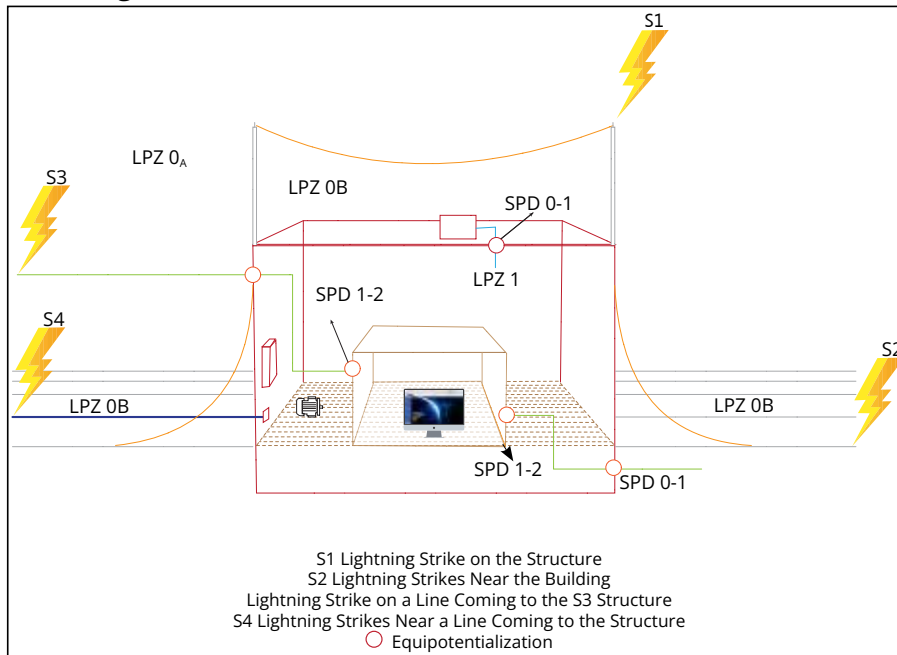







LPZ 0A: This is an open area not protected by an external lightning protection system. Equipment in this area must be exposed to direct lightning strikes and withstand all lightning current and magnetic field effects.

LPZ 0B: This is an open area protected by an external lightning protection system. Equipment in this area is protected against direct lightning strikes but is completely unprotected from magnetic field effects.

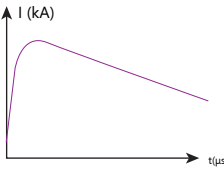
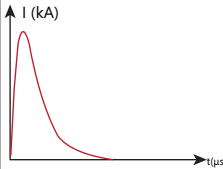
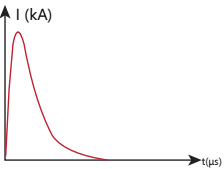
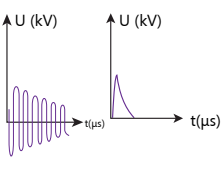
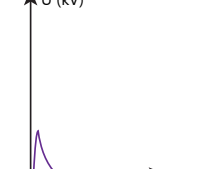
LPZ 1: This is the inner zone where there is no risk of direct lightning strikes and induced currents are less. Cable armoring has been installed in this zone, and a first-level low-voltage surge arrester has been installed.

LPZ 2, LPZ n: more advanced armoring and more sensitive A.G. surge arresters These are different zones where more sensitive protection is provided at each stage, obtained by reducing the induced current using

When determining the protection zones, A.G surge arrester selection can be made according to the table below.

	LPZ 0 _A	LPZ 0 _B	LPZ 1	LPZ 2	LPZ 3
Electromagnetic Field		Normal	Reduced		Very Reduced
Power lines current waveform flowing through	<p>Direct Lightning strike 10/350μs lightning current</p> <p>Electromagnetic field coupling due to direct lightning strike 8/20μs</p> <p>Pulses from the mains 8/20μs</p> 	<p>Electromagnetic field coupling due to direct lightning strike 8/20μs</p> <p>Voltage pulses from the mains 8/20μs</p> 	<p>Electromagnetic field coupling due to direct lightning strike 8/20μs</p> <p>Voltage pulses from the mains 8/20μs</p> 	<p>Reduced effect of the electromagnetic field and voltage surges occurring in the internal network 1.2/50μs voltage surge</p> 	<p>Very low energy voltage surge and electromagnetic field 1.2/50μs voltage surge</p> 
Region to be attached at the entrance A.G. Parafudr		<p>TYPE 1</p> 	<p>TYPE 1+2</p>  <p>TYPE 2</p> 	<p>TYPE 2</p> 	<p>TYPE 3</p> 

3- Types of Electrical Distribution Networks

TN-C-S Network

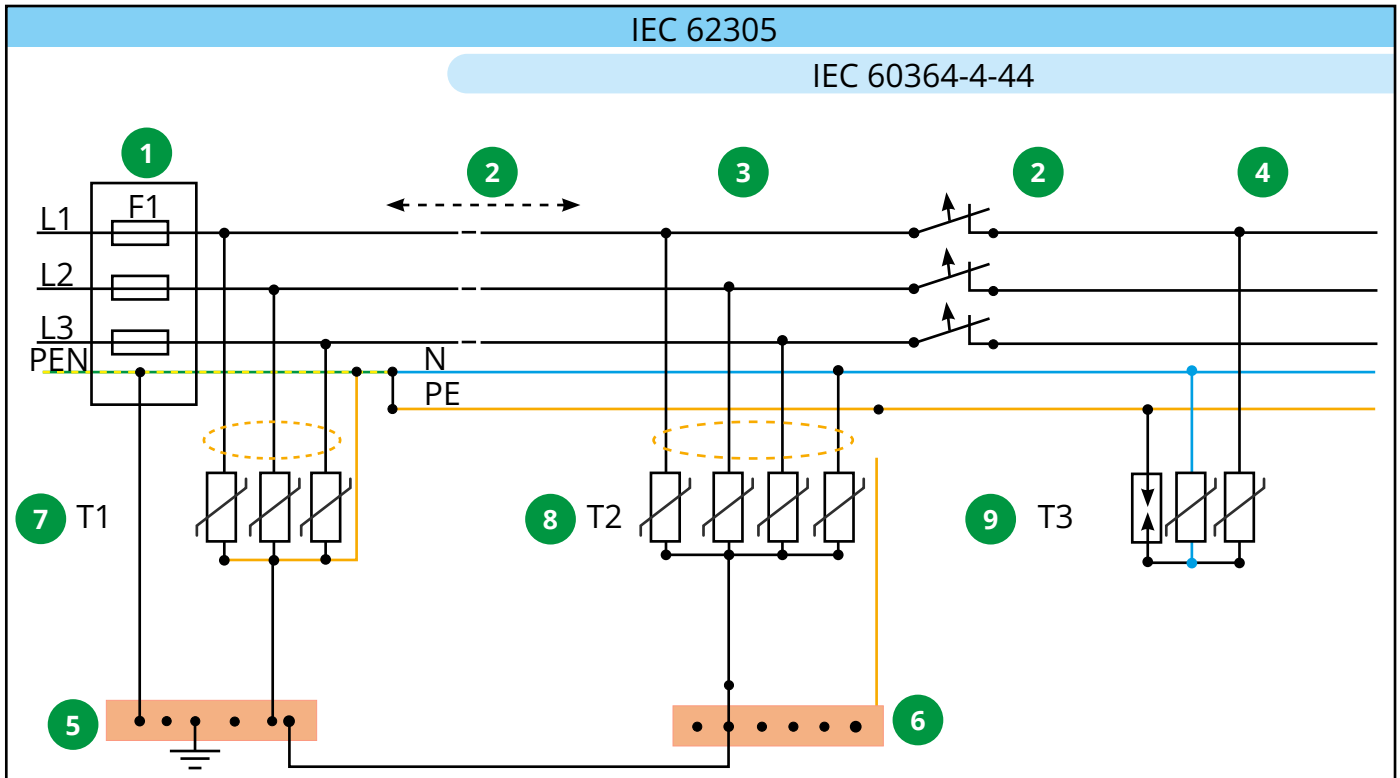

1 Main Panels and Fuses	6 Tali Equipotential Grounding Barası
2 SPD the Cable Length between Dec	7 Type 1 (Class I, SPD) Impact Protector
3 Distribution Table	8 Type 2 (Class II, SPD) Impact Protector
4 The Most End-to Device in the Installation (Last Point)	9 Type 3 (Class III, SPD) Impact Protector
5 Main Grounding Busbar	— Areas Where Pre-Insurance Will Be Applied

In a TN-C network, the electrical installation is fed from the three-phase line (L1, L2, L3) and the combined PEN line.

The use is described in IEC 60364-5-53.

Type 1 lightning arresters are used between phase lines and ground at the power input (main panel).

Type 2 surge arresters are used in distribution panels. With a 3+1 circuit, the phase lines (L1, L2, L3) are connected to the neutral (N) using varistors. The neutral is connected to protective grounding via an arc-gap surge arrester.

Type 3 surge arresters are used in device feeds. Varistors connected to the phase (L) and neutral (N) lines are connected to protective earth (PE) via an arc-gap protector.

TN-S and TT Networks

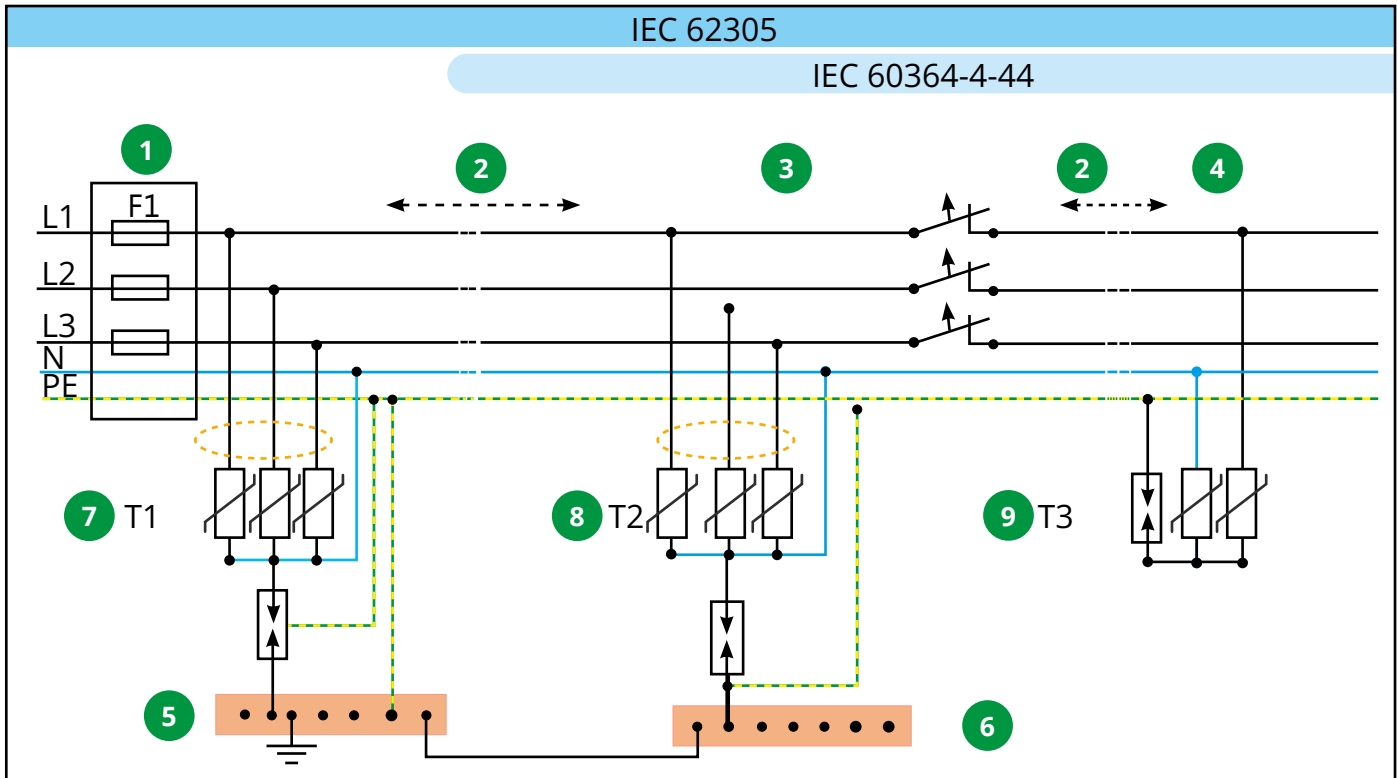

1 Main Panels and Fuses	6 Tali Equipotential Grounding Barası
2 SPD the Cable Length between Dec	7 Type 1 (Class I, SPD) Impact Protector
3 Distribution Table	8 Type 2 (Class II, SPD) Impact Protector
4 The Most End-to Device in the Installation (Last Point)	9 Type 3 (Class III, SPD) Impact Protector
5 Main Grounding Busbar	-- Areas Where Pre-Insurance Will Be Applied

In a TN-S network, the electrical installation is supplied by three phase lines (L1, L2, L3), a neutral cable (N) of the same potential, and an earth cable (PE). However, in a TT network, the electrical unit is supplied by three phase lines (L1, L2, L3), a separately grounded (neutral ground) operating cable (N), and a protective earth cable (PE). The use is described in IEC 61643-11.

Type 1 surge arresters are used at the power input and main switchboard. With a 3+1 circuit, the phase lines (L1, L2, L3) are connected to neutral (N) using varistors or arc-gap surge arresters. The neutral is connected to protective grounding via an arc-gap surge arrester. With the permission of the energy distribution company, surge arresters can also be installed before the main meter.

Type 2 surge arresters are used in distribution panels. With a 3+1 circuit, the phase lines (L1, L2, L3) are connected to the neutral (N) via surge arresters. The neutral is connected to the protective earth via an arc-gap surge arrester.

Type 3 surge arresters are used at device inputs to protect devices against surges. These surges occur primarily between phase (L) and neutral (N). Protected by varistor circuits, the L and N lines are connected to protective earthing via arc-gap surge arresters. This protective circuit between L and N prevents surge currents resulting from transverse voltages directed towards protective earthing (PE).

4- Technical Specifications of Low Voltage Surge Arresters

After determining the protection zones of the building and the type of electrical network, A.G. surge arresters suitable for the technical specifications of the network and the protected equipment should be selected.

1. Continuous Operating Voltage, U_c

The continuous operating voltage of the low voltage surge arrester must be higher than the highest continuous operating voltage of the power system. The lowest recommended U_c values for low voltage surge arresters can be selected according to the table below.

	NETWORK TYPE				
	TT	TN-C	TN-S	IT, Distributed Neutral	IT, Distributed Neutral
Each phase line and neutral	$1,1 \times U_0$	-	$1,1 \times U_0$	$1,1 \times U_0$	-
Each phase line and earth (PE)	$1,1 \times U_0$	-	$1,1 \times U_0$	$\sqrt{3} \times U_0$	Interphase voltage
Neutral and ground (PE)	U_0	-	U_0	U_0	-
Each phase line and PEN	-	$1,1 \times U_0$	-	-	-

U_0 : phase-neutral voltage of the system

2. Transient overvoltage level, U_T

U_T must be greater than the transient overvoltage expected on the System.

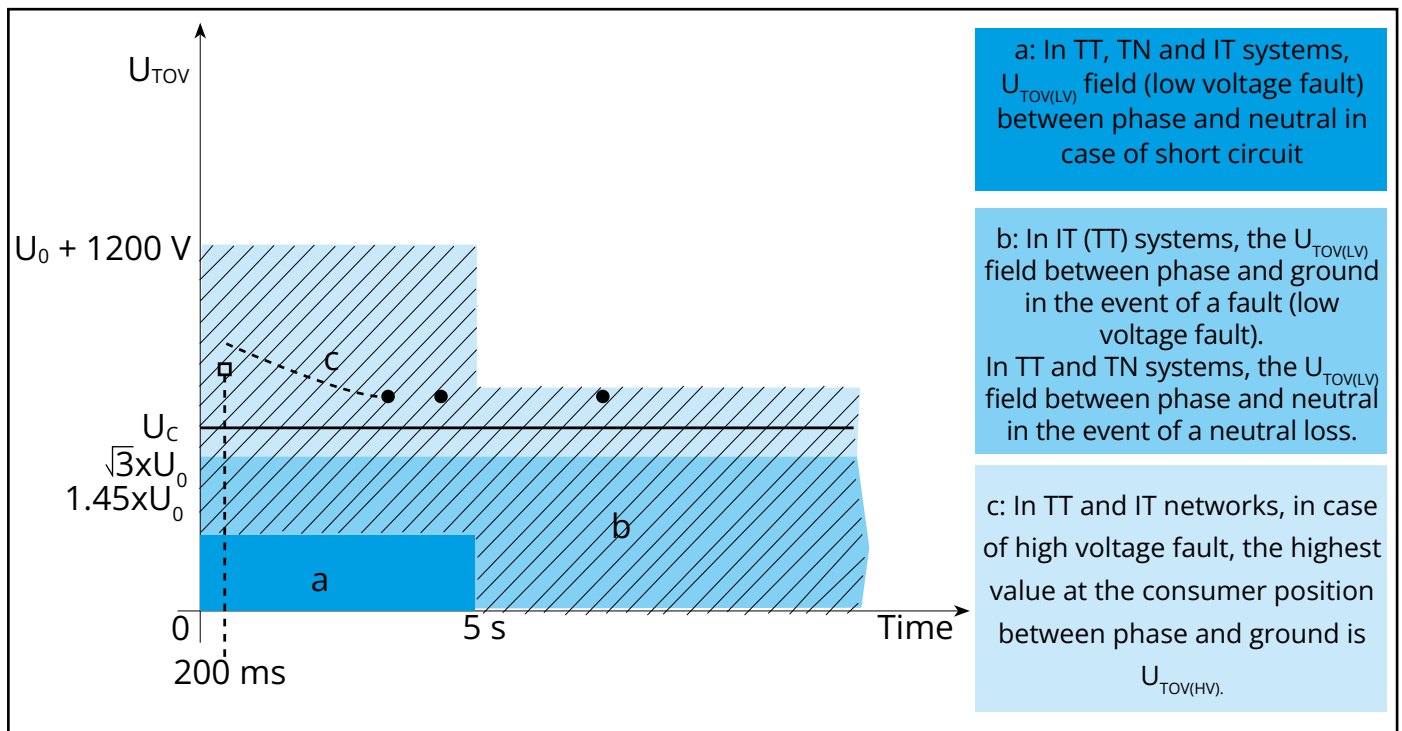

3. In, Iimp

Nominal Discharge Current, I_n , is for Type 2 A.G. surge arresters.

According to the IEC 61643-12 standard, according to the connection below, I_n cannot be less than 20 kA in 8/20 μ s waveform in 3-phase systems and 10 kA in 8/20 μ s single-phase systems.

Lightning Impulse Current, I_{imp} , for Type 1 A.G. surge arresters.

For each protection mode, the current cannot be less than 12.5 kA on a 10/350 μ s waveform. In three-phase systems, it cannot be less than 50 kA on a 10/350 μ s waveform, and in single-phase systems, it cannot be less than 25 kA on a 10/350 μ s waveform.

4. Protection Distance

To determine the location where the L.V. surge arrester will be installed (near the main panel, equipment, etc.), it is necessary to know the acceptable distance between the L.V. surge arrester and the protected equipment.

5. Compatibility of A.G. surge arresters and other devices to be used

The continuous operating current, I_c , should not cause failure in devices such as residual current circuit breakers. I_c should be less than one-third of the residual current $I_{\Delta n}$. It should be noted that residual current circuit breakers, fuses, and circuit breakers installed on the load side will not protect these devices.

6. Voltage protection level, U_p

Every device has an impulse withstand voltage. The U_p value of the L.V. surge arrester must be selected according to the impulse withstand voltage of the equipment to be protected.

7. Additional features

Modular Design: Radsan A.G. surge arresters are designed in two main sections: functional and connection sections that are compatible with each other. The components that provide protection within the modules,

It is installed in the connection section where the DIN rail and cable connections are made.

Life Indicator: Low Voltage Surge Arresters can fail as a result of impacts occurring over many years. Indicators showing the operating status of the Low Voltage Surge Arrester can help determine the condition and determine the need for maintenance.

Fault Warning: In systems with a communication infrastructure, the fault status can be communicated to any user via the dry contact from the LV surge arrester.





POWER SYSTEMS and DATA SYSTEMS



- High level protection is provided by hybrid technology in which varistors and GDT are used together.
- Thanks to its compact design, SPD can be used easily even in the narrowest panels.
- Fault status can be monitored with the indicators on the SPD.
- With the dry contact output, the fault status can be monitored remotely.
- Designed and manufactured in Turkiye.
- 5 years of warranty
- **TUV certificated**

T1+T2 Class SPD according to EN 61643-11.
Combination: 3+1, TT and TN-S Network



SRG T1 3P+N 150 | SRG T1 3P+N 275 | SRG T1 3P+N 385

Electrical Features				
Nominal AC Voltage (50/60Hz)	Un	130V	240V	230V
Max. Continuous Operating Voltage (L-N)	Uc	150V	275V	385V
Nominal discharge current (8/20µs)	In	50 kA (L-N) / 100 kA (N-PE)		
Max. discharge current (8/20µs)	I _{max}	75 kA (L-N) / 160 kA (N-PE)		
Lightning impulse current (10/350µs)	I _{imp}	50 kA (L-N) / 100 kA (N-PE)		
Voltage protection level	Up	≤0,8 kV	≤1,3 kV	≤1,8 kV
Response time	tA	≤25ns / ≤100ns		
Max. backup fuse		315 A gL/gG		
Temporary overvoltage- 120 min. (L-N)	UT	235V	440V	526V
Temporary overvoltage-200 ms (N-PE)	UT	1200V		
Follow current extinguishing capability (N-PE)	I _{fi}	100 A _{RMS}		
Mechanical Features				
Operating temperature range	Ta	-40 C° to +80 C°		
Humidity	RH	5%....%90		
Tightening Torque	M _{max}	4,5 Nm		
Cable Cross-sectional area (max.)		35 mm ² Solid / Stranded / 25 mm ² Fleksible		
For mounting on		35 mm DIN Rail EN 60715		
Casing Material		Thermoplastic, UL 94 V-0		
Degree of protection		IP20		
Specific Features				
Modular		YES		
Fault Indicators		Green for ok / Red for fault		
Remote Fault Signaling		YES		
Thermal Protection		YES		
Warranty		5 years		



CIRCUIT DIAGRAM

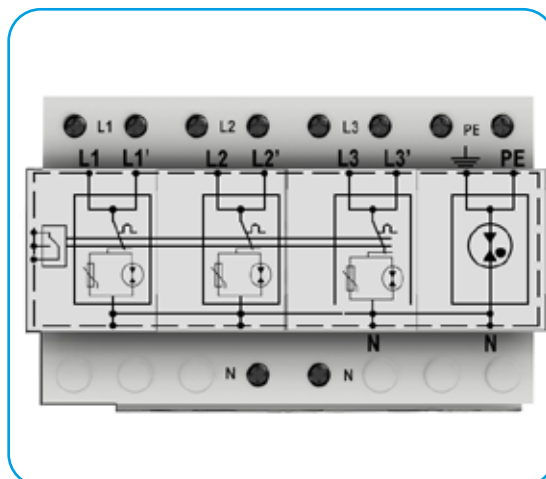

DIMENSIONS

Product Weight	812 gr
Packaged Weight	855 gr
Package Dimensions(ExBxY)	80x150x105 mm

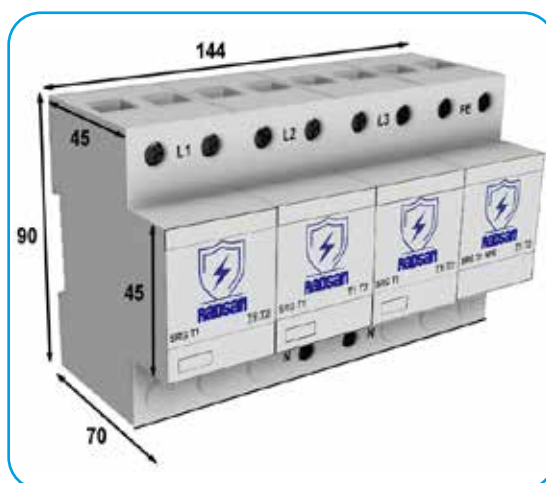

CONNECTION DIAGRAM

Series

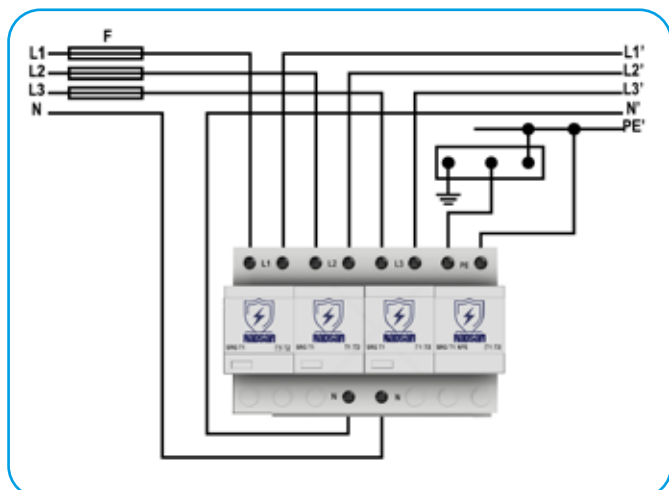

Parallel

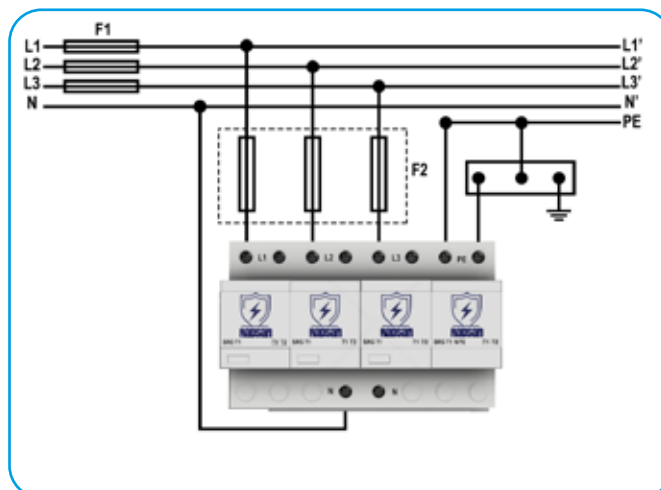



- High level protection is provided by hybrid technology in which varistors and GDT are used together.
- Thanks to its compact design, SPD can be used easily even in the narrowest panels.
- Fault status can be monitored with the indicators on the SPD.
- With the dry contact output, the fault status can be monitored remotely.
- Designed and manufactured in Turkiye.
- 5 years of warranty
- **TUV certificated**



T1+T2 Class SPD according to EN 61643-11.

		SRG T1 1P+N 150	SRG T1 1P+N 275	SRG T1 1P+N 385
Electrical Features				
Nominal AC Voltage (50/60Hz)	Un	130V	240V	230V
Max. Continuous Operating Voltage (L-N)	Uc	150V	275V	385V
Nominal discharge current (8/20µs)	In	50 kA (L-N) / 100 kA (N-PE)		
Max. discharge current (8/20µs)	I _{max}	75 kA (L-N) / 160 kA (N-PE)		
Lightning impulse current (10/350µs)	I _{imp}	50 kA (L-N) / 100 kA (N-PE)		
Voltage protection level	Up	≤0,8 kV	≤1,3 kV	≤1,8 kV
Response time	tA	≤25ns / ≤100ns		
Max. backup fuse		315 A gL/gG		
Geçici Aşırı Gerilim 120 dak. (L-N)	UT	235V	440V	526V
Temporary overvoltage-200 ms (N-PE)	UT	1200V		
Follow current extinguishing capability (N-PE)	I _{fi}	100 A _{RMS}		
Mechanical Features				
Operating temperature range	Ta	-40 C° to +80 C°		
Humidity	RH	5%...%90		
Tightening Torque	M _{max}	4,5 Nm		
Cable Cross-sectional area (max.)		35 mm ² Solid / Stranded / 25 mm ² Flexible		
For mounting on		35 mm DIN Rail EN 60715		
Casing Material		Thermoplastic, UL 94 V-0		
Degree of protection		IP20		
Specific Features				
Modular		YES		
Fault Indicators		Green for ok / Red for fault		
Remote Fault Signaling		YES		
Thermal Protection		YES		
Warranty		5 YEARS		



CIRCUIT DIAGRAM

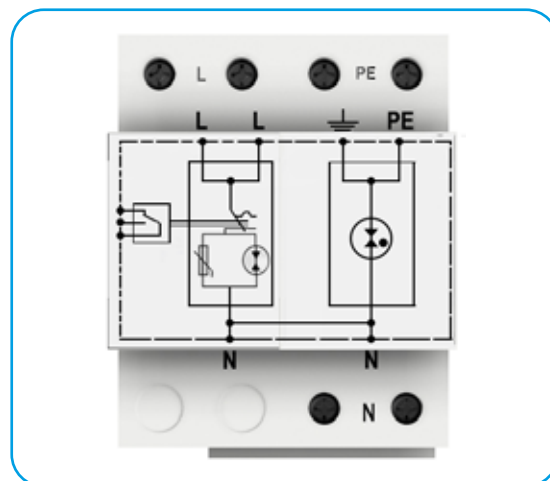

DIMENSIONS

Product Weight	435 gr
Packaged Weight	460 gr
Paket DIMENSIONSİ (ExBxY) (ExBxY)(ExBxY)	80x75x105 mm.

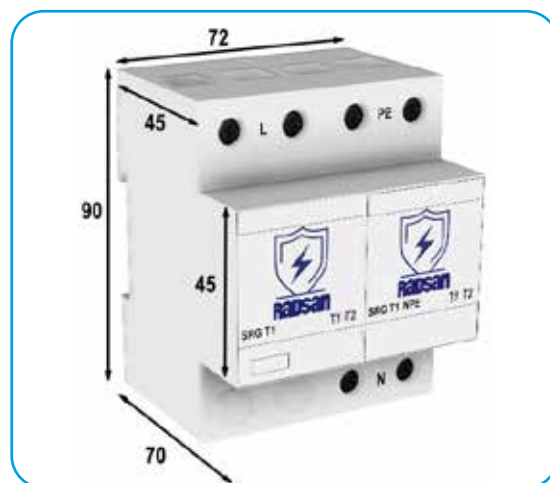

CONNECTION DIAGRAM

Series

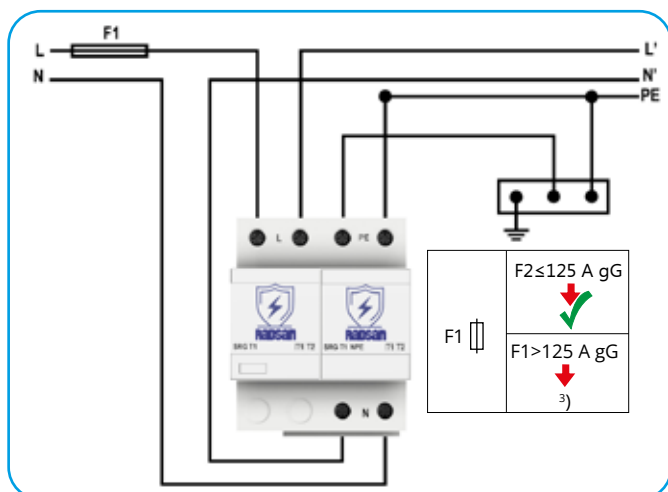

Parallel

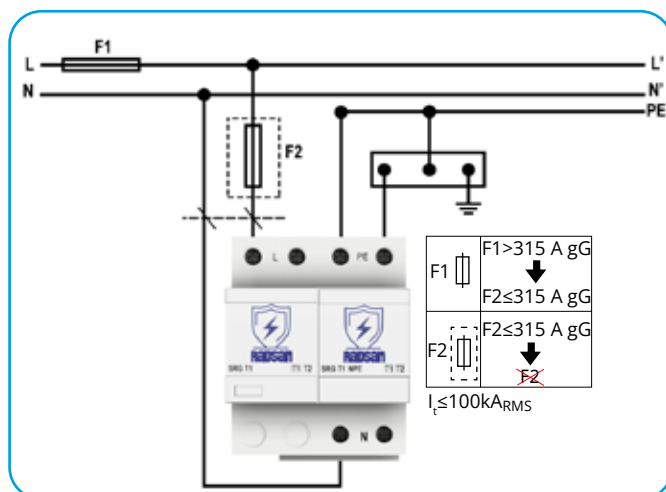



- High level protection is provided by hybrid technology in which varistors and GDT are used together.
- Thanks to its compact design, SPD can be used easily even in the narrowest panels.
- Fault status can be monitored with the indicators on the SPD.
- With the dry contact output, the fault status can be monitored remotely.
- Designed and manufactured in Turkiye.
- 5 years of warranty
- **TUV certificated**



T1+T2 Class SPD according to EN 61643-11.

		SRG T1 4P 150	SRG T1 4P 275	SRG T1 4P 385
Electrical Features				
Nominal AC Voltage (50/60Hz)	Un	130V	240V	230V
Max. Continuous Operating Voltage (L-N)	Uc	150V	275V	385V
Nominal discharge current (8/20µs)	In	50 kA		
Max. discharge current (8/20µs)	I _{max}	160 kA		
Lightning impulse current (10/350µs)	I _{imp}	50 kA		
Voltage protection level	Up	≤0,8 kV	≤1,3 kV	≤1,5 kV
Response time	tA	≤25ns / ≤100ns		
Max. backup fuse		315 A gL/gG		
Temporary overvoltage- 120 min. (L-N)	UT	235V	440V	526V
Temporary overvoltage-200 ms (N-PE)	UT	1200V		
Follow current extinguishing capability (N-PE)	I _{fi}	100 A _{RMS}		
Mechanical Features				
Operating temperature range	Ta	-40 C° to +80 C°		
Humidity	RH	5%...%90		
Tightening Torque	M _{max}	4,5 Nm		
Cable Cross-sectional area (max.)		35 mm ² Solid / Stranded / 25 mm ² Flexible		
For mounting on		35 mm DIN Rail EN 60715		
Casing Material		Thermoplastic, UL 94 V-0		
Degree of protection		IP20		
Specific Features				
Modular		YES		
Fault Indicators		Green for ok / Red for fault		
Remote Fault Signaling		YES		
Thermal Protection		YES		
Warranty		5 YEARS		



CIRCUIT DIAGRAM

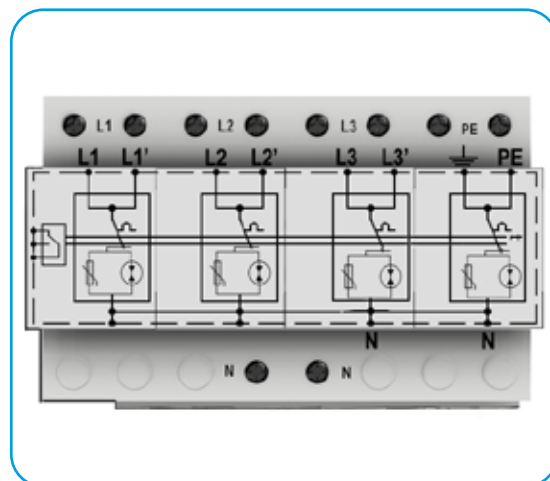

DIMENSIONS

Product Weight:	812 gr.
Packaged Weight:	855 gr.
Package Dimensions (ExBxY)	80x150x105 mm.

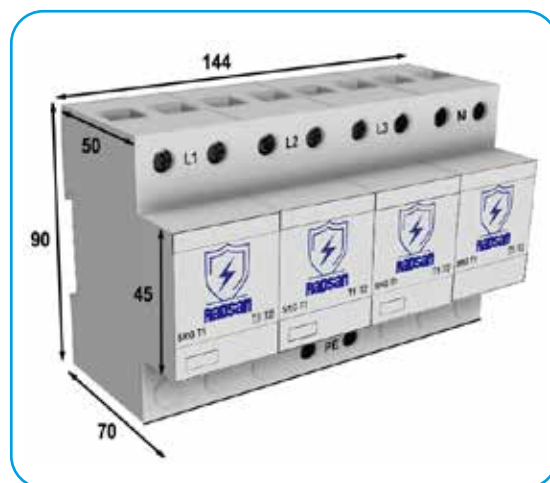

CONNECTION DIAGRAM

Series

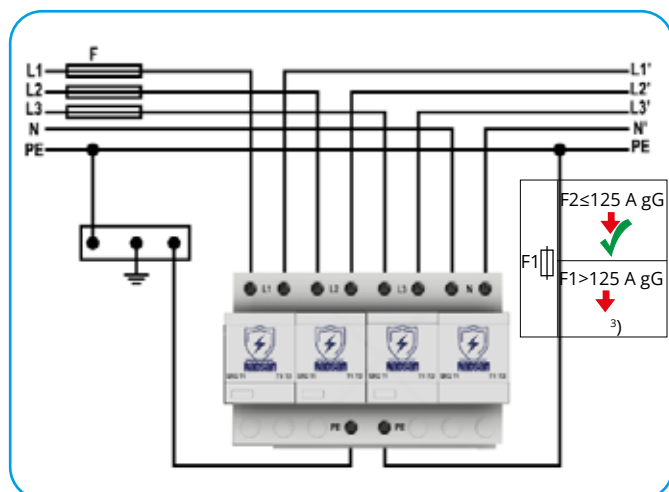

Parallel

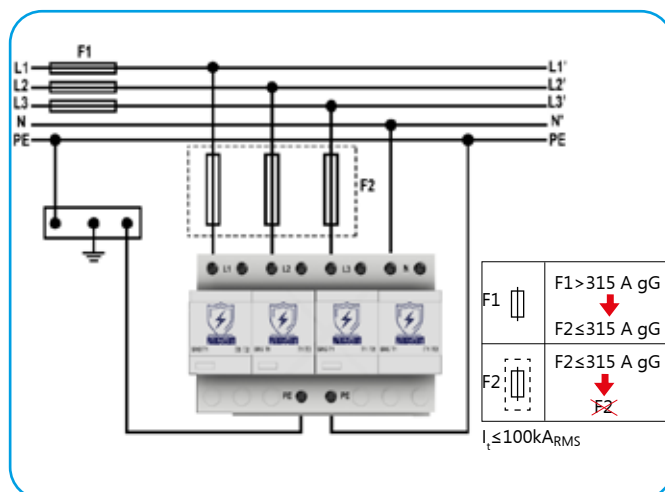



- High level protection is provided by hybrid technology in which varistors and GDT are used together.
- Thanks to its compact design, SPD can be used easily even in the narrowest panels.
- Fault status can be monitored with the indicators on the SPD.
- With the dry contact output, the fault status can be monitored remotely.
- Designed and manufactured in Turkiye.
- 5 years of warranty
- **TUV certificated**



T1+T2 Class SPD according to EN 61643-11.

SRG T1 3P 150 | SRG T1 3P 275 | SRG T1 3P 385

Electrical Features				
Nominal AC Voltage (50/60Hz)	Un	130V	240V	230V
Max. Continuous Operating Voltage (L-N)	Uc	150V	275V	385V
Nominal discharge current (8/20µs)	In	50 kA		
Max. discharge current (8/20µs)	I _{max}	160 kA		
Lightning impulse current (10/350µs)	I _{imp}	50 kA		
Voltage protection level	Up	≤0,8 kV	≤1,3 kV	≤1,5 kV
Response time	t _A	≤25ns / ≤100ns		
Max. backup fuse		315 A gL/gG		
Temporary overvoltage- 120 min. (L-N)	UT	235V	440V	526V
Temporary overvoltage-200 ms (N-PE)	UT	1200V		
Follow current extinguishing capability (N-PE)	I _{fi}	100 A _{RMS}		

Mechanical Features				
Operating temperature range	T _a	-40 C° to +80 C°		
Humidity	RH	5%...%90		
Tightening Torque	M _{max}	4,5 Nm		
Cable Cross-sectional area (max.)		35 mm ² Solid / Stranded / 25 mm ² Flexible		
For mounting on		35 mm DIN Rail EN 60715		
Casing Material		thermoplastic, UL 94 V-0		
Degree of protection		IP20		

Specific Features				
Modular		YES		
Fault Indicators		Green for ok / Red for fault		
Remote Fault Signaling		YES		
Thermal Protection		YES		
Warranty		5 YEARS		



CIRCUIT DIAGRAM

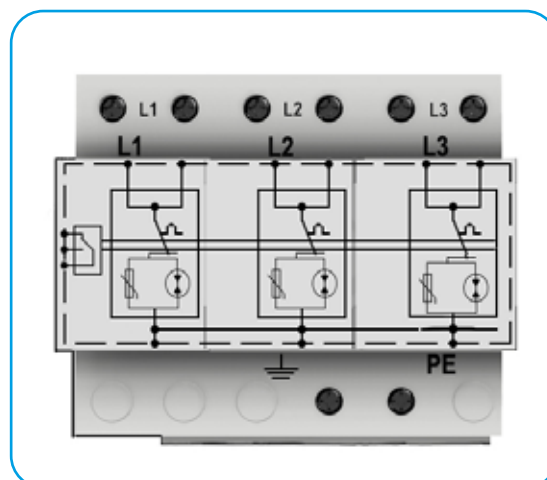

DIMENSIONS

Product Weight:	610 gr
Packaged Weight:	650 gr
Package Dimensions (ExBxY)	80x115x105 mm.

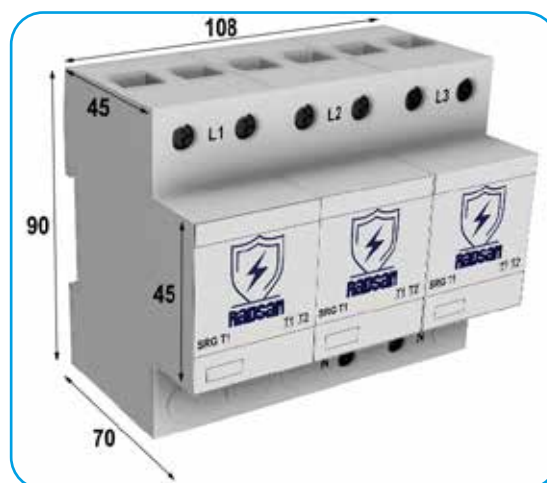

CONNECTION DIAGRAM

Series

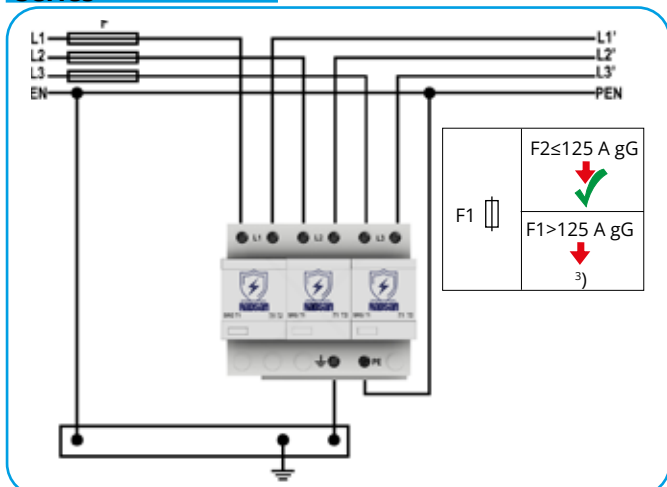

Parallel

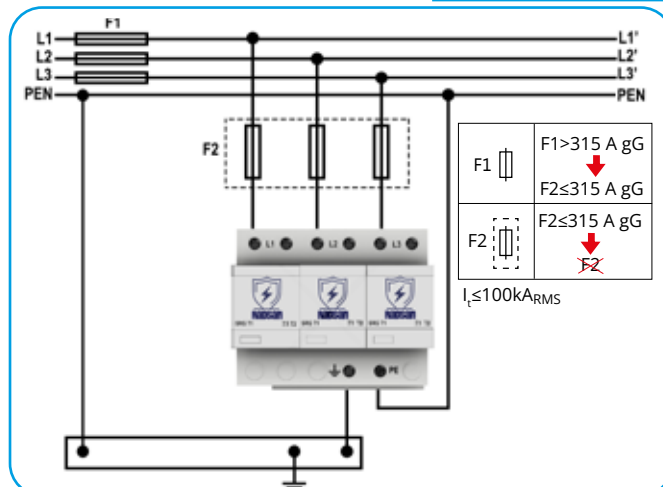



- High level protection is provided by hybrid technology in which varistors and GDT are used together.
- Thanks to its compact design, SPD can be used easily even in the narrowest panels.
- Fault status can be monitored with the indicators on the SPD.
- With the dry contact output, the fault status can be monitored remotely.
- Designed and manufactured in Turkiye.
- 5 years of warranty
- **TUV certificated**



2+0

TN

T1+T2 Class SPD according to EN 61643-11.

		SRG T1 2P 150	SRG T1 2P 275	SRG T1 2P 385
Electrical Features				
Nominal AC Voltage (50/60Hz)	Un	130V	240V	230V
Max. Continuous Operating Voltage (L-N)	Uc	150V	275V	385V
Nominal discharge current (8/20µs)	In	50 kA		
Max. discharge current (8/20µs)	Imax	160 kA		
Lightning impulse current (10/350µs)	Iimp	50 kA		
Voltage protection level	Up	≤0,8 kV	≤1,3 kV	≤1,5 kV
Response time	tA	≤25ns / ≤100ns		
Max. backup fuse		315 A gL/gG		
Temporary overvoltage- 120 min. (L-N)	UT	235V	440V	526V
Temporary overvoltage-200 ms (N-PE)	UT	1200V		
Follow current extinguishing capability (N-PE)	Ifi	100 A _{RMS}		
Mechanical Features				
Operating temperature range	Ta	-40 C° to +80 C°		
Humidity	RH	5%...%90		
Tightening Torque	Mmax	4,5 Nm		
Cable Cross-sectional area (max.)		35 mm ² Solid / Stranded / 25 mm ² Flexible		
For mounting on		35 mm DIN Rail EN 60715		
Casing Material		Thermoplastic, UL 94 V-0		
Degree of protection		IP20		
Specific Features				
Modular		YES		
Fault Indicators		Green for ok / Red for fault		
Remote Fault Signaling		YES		
Thermal Protection		YES		
Warranty		5 YEARS		



CIRCUIT DIAGRAM

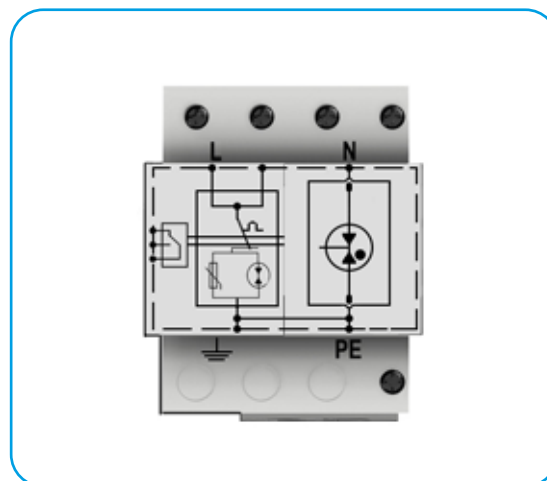

DIMENSIONS

Product Weight:	435 gr
Packaged Weight:	460 gr
Package Dimensions (ExBxY)	80x75x105

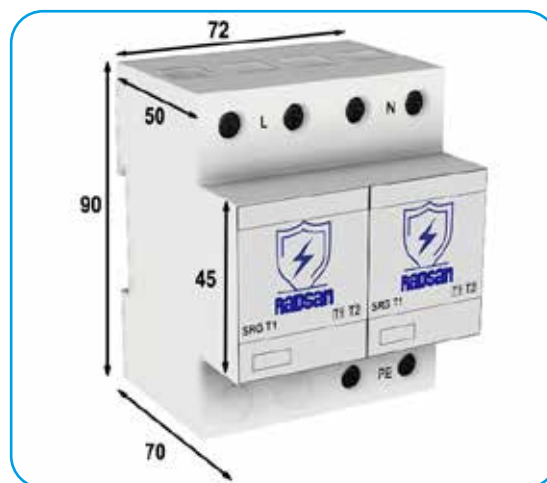

CONNECTION DIAGRAM

Series

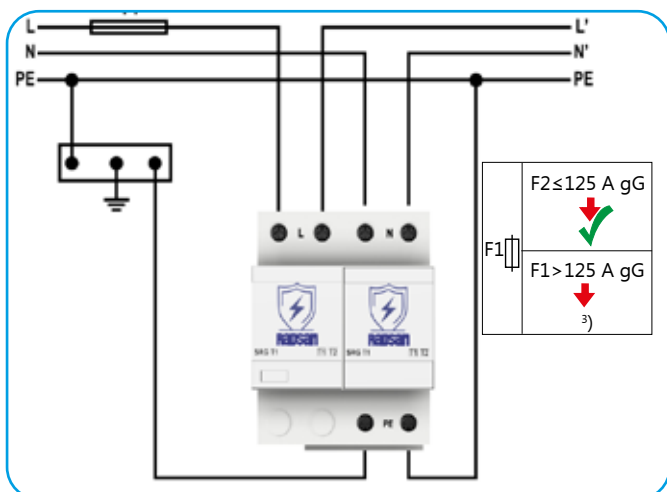

Parallel

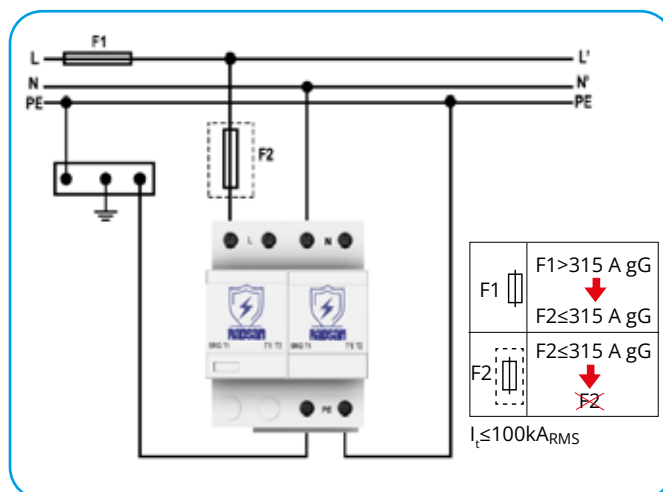



- High level protection is provided by hybrid technology in which varistors and GDT are used together.
- Thanks to its compact design, SPD can be used easily even in the narrowest panels.
- Fault status can be monitored with the indicators on the SPD.
- With the dry contact output, the fault status can be monitored remotely.
- Designed and manufactured in Turkiye.
- 5 years of warranty
- **TUV certificated**



T1+T2 Class SPD according to EN 61643-11.

		SRG T1 1P 150	SRG T1 1P 275	SRG T1 1P 385
Electrical Features				
Nominal AC Voltage (50/60Hz)	Un	130V	240V	230V
Max. Continuous Operating Voltage (L-N)	Uc	150V	275V	385V
Nominal discharge current (8/20µs)	In	50 kA		
Max. discharge current (8/20µs)	I _{max}	160 kA		
Lightning impulse current (10/350µs)	I _{imp}	50 kA		
Voltage protection level	Up	≤0,8 kV	≤1,3 kV	≤1,5 kV
Response time	t _A	≤25ns / ≤100ns		
Max. backup fuse		315 A gL/gG		
Temporary overvoltage- 120 min. (L-N)	UT	235V	440V	526V
Temporary overvoltage-200 ms (N-PE)	UT	1200V		
Follow current extinguishing capability (N-PE)	I _{fi}	100 A _{RMS}		
Mechanical Features				
Operating temperature range	T _a	-40 C° to +80 C°		
Humidity	RH	5%...%90		
Tightening Torque	M _{max}	4,5 Nm		
Cable Cross-sectional area (max.)		35 mm ² Solid / Stranded / 25 mm ² Flexible		
For mounting on		35 mm DIN Rail EN 60715		
Casing Material		Thermoplastic, UL 94 V-0		
Degree of protection		IP20		
Specific Features				
Modular		YES		
Fault Indicators		Green for ok / Red for fault		
Remote Fault Signaling		YES		
Thermal Protection		YES		
Warranty		5 YEARS		



CIRCUIT DIAGRAM

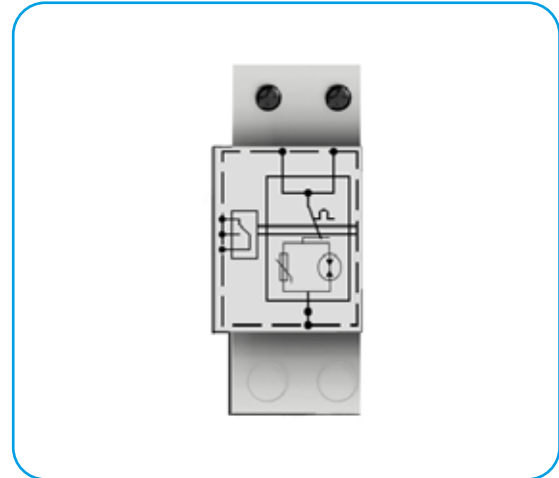

DIMENSIONS

Product Weight:	210 gr
Packaged Weight:	235 gr
Package Dimensions (ExBxY)	80x40x105 mm.

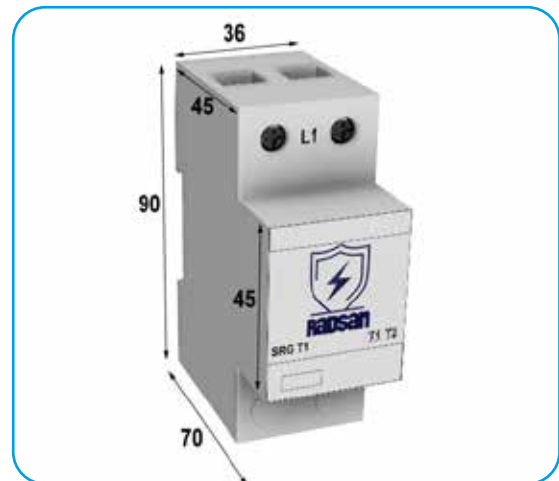



- High level protection is provided by hybrid technology in which varistors and GDT are used together.
- Thanks to its compact design, SPD can be used easily even in the narrowest panels.
- Low maintenance cost thanks to modular design.
- Fault status can be monitored with the indicators on the SPD.
- With the dry contact output, the fault status can be monitored remotely.
- Designed and manufactured in Turkiye.
- 5 years of warranty

3+1

TT
TN-S

T1+T2 Class SPD according to EN 61643-11.

Combination: 3+1, TT and TN-S Network

		SRG T1 3P+N V150	SRG T1 3P+N V275	SRG T1 3P+N V320
Electrical Features				
Nominal AC Voltage (50/60Hz)	Un	130V	240V	300V
Max. Continuous Operating Voltage (L-N)	Uc	150V	275V	320V
Nominal discharge current (8/20µs)	In	20 kA (L-N)		
Max. discharge current (8/20µs)	I _{max}	100 kA		
Lightning impulse current (10/350µs)	I _{imp}	12,5 kA (L-N) / 25 kA (N-PE)		
Voltage protection level	Up	≤0,8 kV	≤1,5 kV	≤1,5 kV
Response time	t _A	≤25ns / ≤100ns		
Max. backup fuse		125 A gL/gG		
Temporary overvoltage- 120 min. (L-N)	UT	235V	440V	526V
Temporary overvoltage-200 ms (N-PE)	UT	1200V		
Follow current extinguishing capability (N-PE)	I _{fi}	100 A _{RMS}		
Mechanical Features				
Operating temperature range	T _a	-40 C° to +80 C°		
Humidity	RH	5%...%90		
Tightening Torque	M _{max}	4,5 Nm		
Cable Cross-sectional area (max.)		35 mm ² Solid / Stranded / 25 mm ² Flexible		
For mounting on		35 mm DIN Rail EN 60715		
Casing Material		Thermoplastic, UL 94 V-0		
Degree of protection		IP20		
Specific Features				
Modular		YES		
Fault Indicators		Green for ok / Red for fault		
Remote Fault Signaling		YES		
Thermal Protection		YES		
Warranty		5 YEARS		



CIRCUIT DIAGRAM

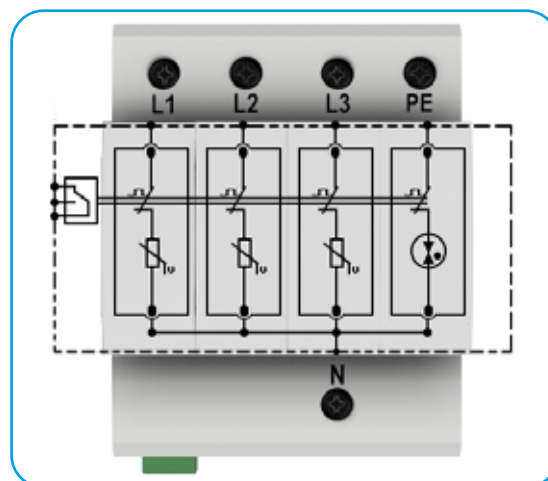

DIMENSIONS

Product Weight:	500 gr
Packaged Weight:	530 gr
Package Dimensions (ExBxY)	80x100x75

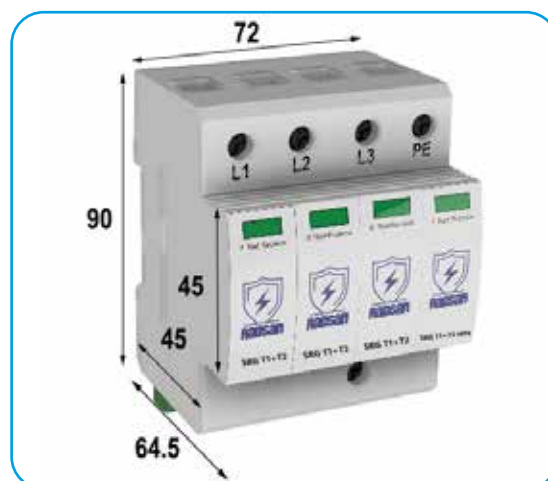

CONNECTION DIAGRAM

TN-S

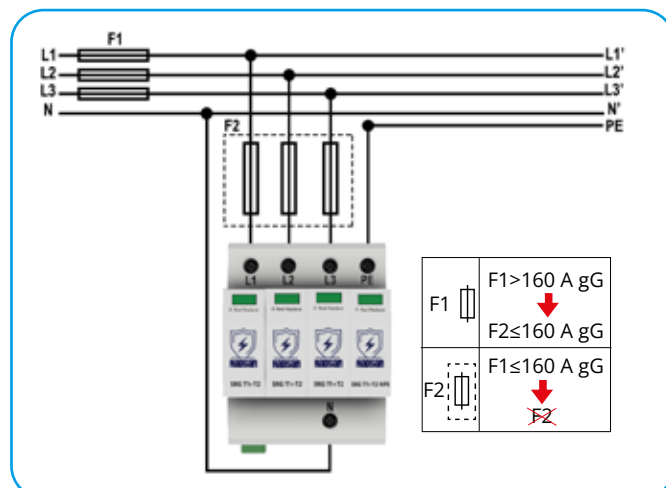
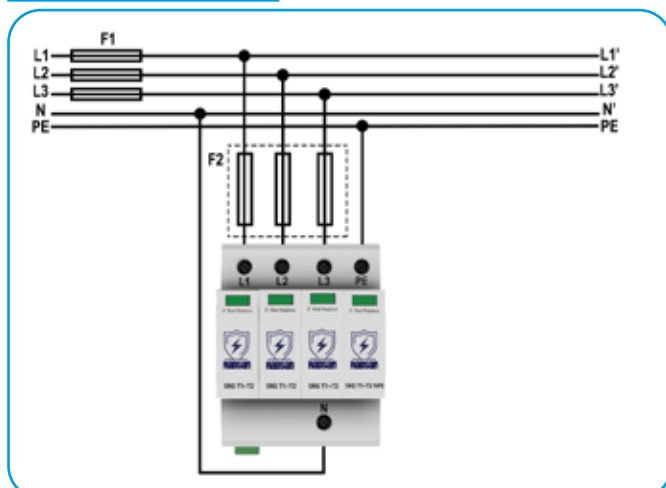



- High level protection is provided by hybrid technology in which varistors and GDT are used together.
- Thanks to its compact design, SPD can be used easily even in the narrowest panels.
- Low maintenance cost thanks to modular design.
- Fault status can be monitored with the indicators on the SPD.
- With the dry contact output, the fault status can be monitored remotely.
- Designed and manufactured in Turkiye.
- 5 years of warranty

T1+T2 Class SPD according to EN 61643-11.

1+1

TT
TN-S

		SRG T1 1P+N V150	SRG T1 1P+N V275	SRG T1 1P+N V320
Electrical Features				
Nominal AC Voltage (50/60Hz)	Un	130V	240V	300V
Max. Continuous Operating Voltage (L-N)	Uc	150V	275V	320V
Nominal discharge current (8/20µs)	In	20 kA (L-N)		
Max. discharge current (8/20µs)	I _{max}	60 kA		
Lightning impulse current (10/350µs)	I _{imp}	12,5 kA (L-N) / 25 kA (N-PE)		
Voltage protection level	Up	≤0,8 kV	≤1,5 kV	≤1,5 kV
Response time	t _A	≤25ns		
Max. backup fuse		125 A gL/gG		
Temporary overvoltage- 120 min. (L-N)	UT	235V	440V	526V
Temporary overvoltage-200 ms (N-PE)	UT	1200V		
Follow current extinguishing capability (N-PE)	I _{fi}	100 A _{RMS}		
Mechanical Features				
Operating temperature range	T _a	-40 C° to +80 C°		
Humidity	RH	5%....%90		
Tightening Torque	M _{max}	4,5 Nm		
Cable Cross-sectional area (max.)		35 mm ² Solid / Stranded / 25 mm ² Flexible		
For mounting on		35 mm DIN Rail EN 60715		
Casing Material		Thermoplastic, UL 94 V-0		
Degree of protection		IP20		
Specific Features				
Modular		YES		
Fault Indicators		Green for ok / Red for fault		
Remote Fault Signaling		YES		
Thermal Protection		YES		
Warranty		5 YEARS		



CIRCUIT DIAGRAM

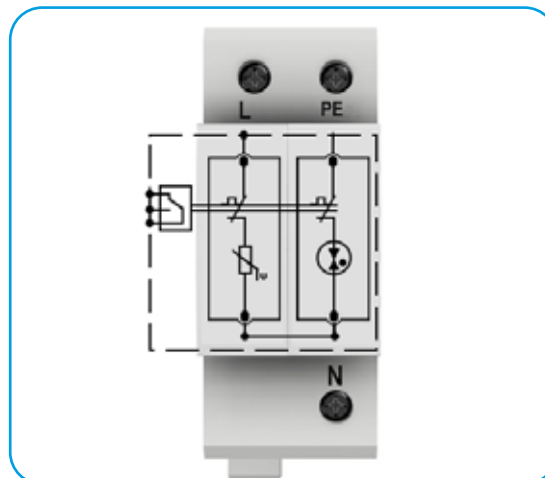

DIMENSIONS

Product Weight:	230 gr
Packaged Weight:	250 gr
Package Dimensions (ExBxY)	40x100x75 mm.

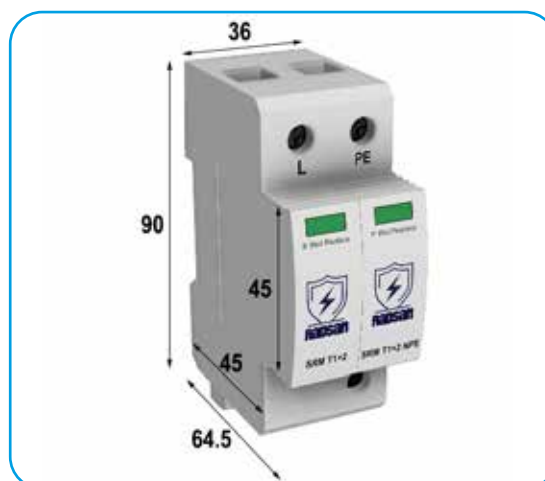

CONNECTION DIAGRAM

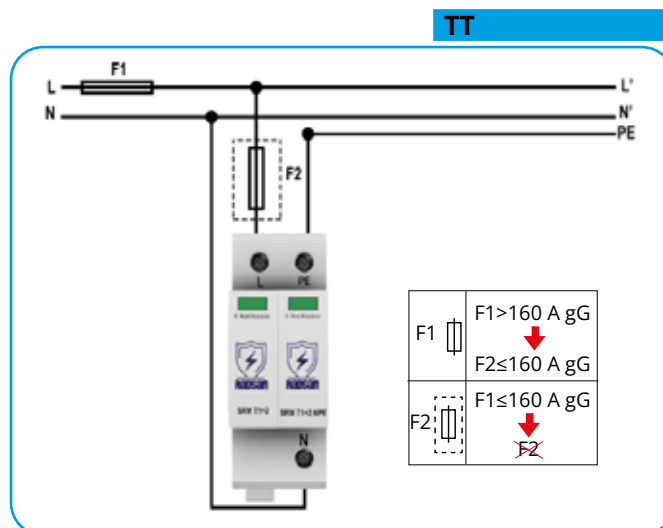
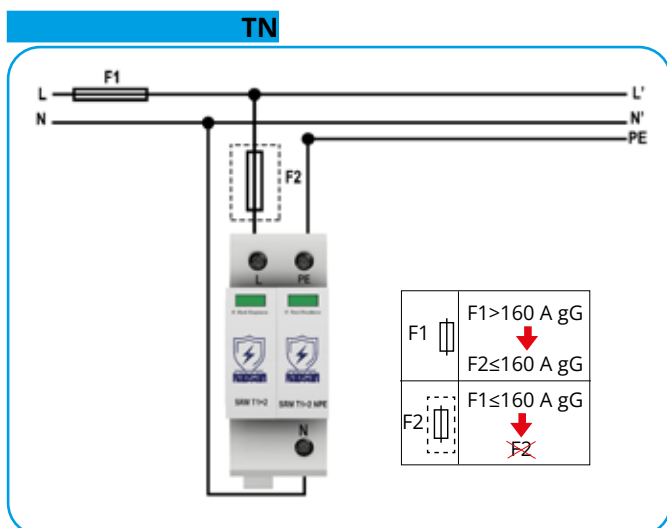



- High level protection is provided by hybrid technology in which varistors and GDT are used together.
- Thanks to its compact design, SPD can be used easily even in the narrowest panels.
- Low maintenance cost thanks to modular design.
- Fault status can be monitored with the indicators on the SPD.
- With the dry contact output, the fault status can be monitored remotely.
- Designed and manufactured in Turkiye.
- 5 years of warranty

T1+T2 Class SPD according to EN 61643-11.

4+0

TN-S

		SRG T1 4P V150	SRG T1 4P V275	SRG T1 4P V320
Electrical Features				
Nominal AC Voltage (50/60Hz)	Un	130V	240V	300V
Max. Continuous Operating Voltage (L-N)	Uc	150V	275V	320V
Nominal discharge current (8/20µs)	In		20 kA	
Max. discharge current (8/20µs)	I _{max}		60 kA	
Lightning impulse current (10/350µs)	I _{imp}		12,5 kA	
Voltage protection level	Up	≤1 kV	≤1,5 kV	≤1,7 kV
Response time	t _A		≤25ns	
Max. backup fuse			315 A / 250 A gL/gG	
TOV withstand 5s.	UT	175V	337V	403V
TOV 120m.	UT	229V	442V	529V
Mechanical Features				
Operating temperature range	T _a		-40 C° to +80 C°	
Humidity	RH		5%...%90	
Tightening Torque	M _{max}		4,5 Nm	
Cable Cross-sectional area (max.)			35 mm ² Solid / Stranded / 25 mm ² Flexible	
For mounting on			35 mm DIN Rail EN 60715	
Casing Material			Thermoplastic, UL 94 V-0	
Degree of protection			IP20	
Specific Features				
Modular			YES	
Fault Indicators			Green for ok / Red for fault	
Remote Fault Signaling			YES	
Thermal Protection			YES	
Warranty			5 YEARS	



- High level protection is provided by hybrid technology in which varistors and GDT are used together.
- Thanks to its compact design, SPD can be used easily even in the narrowest panels.
- Low maintenance cost thanks to modular design.
- Fault status can be monitored with the indicators on the SPD.
- With the dry contact output, the fault status can be monitored remotely.
- Designed and manufactured in Turkiye.
- 5 years of warranty

3+0
TN-C
T1+T2 Class SPD according to EN 61643-11.

		SRG T1 3P V150	SRG T1 3P V275	SRG T1 3P V320
Electrical Features				
Nominal AC Voltage (50/60Hz)	Un	130V	240V	300V
Max. Continuous Operating Voltage (L-N)	Uc	150V	275V	320V
Nominal discharge current (8/20µs)	In	12,5 kA		
Max. discharge current (8/20µs)	I _{max}	60 kA		
Lightning impulse current (10/350µs)	I _{imp}	12,5 kA		
Voltage protection level	Up	≤1 kV	≤1,5 kV	≤1,5 kV
Response time	t _A	≤25ns		
Max. backup fuse		125 A gL/gG		
TOV withstand 5s.	UT	175V	337V	403V
TOV 120m.	UT	229V	442V	529V
Mechanical Features				
Operating temperature range	T _a	-40 C° to +80 C°		
Humidity	RH	5%...%90		
Tightening Torque	M _{max}	4,5 Nm		
Cable Cross-sectional area (max.)		35 mm ² Solid / Stranded / 25 mm ² Flexible		
For mounting on		35 mm DIN Rail EN 60715		
Casing Material		Thermoplastic, UL 94 V-0		
Degree of protection		IP20		
Specific Features				
Modular		YES		
Fault Indicators		Green for ok / Red for fault		
Remote Fault Signaling		YES		
Thermal Protection		YES		
Warranty		5 YEARS		



CIRCUIT DIAGRAM

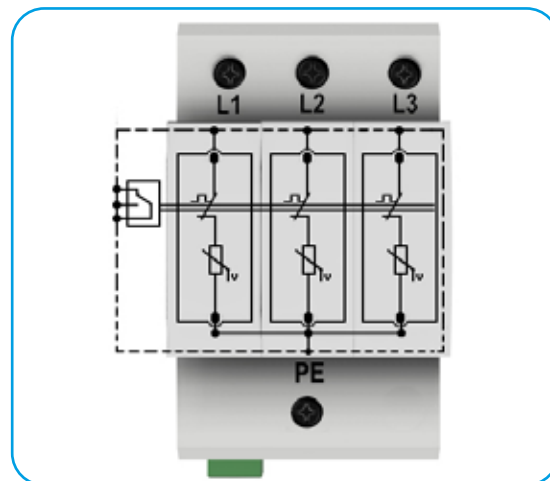

DIMENSIONS

Product Weight:	385 gr
Packaged Weight:	415 gr
Package Dimensions (ExBxY)	60x100x75



CONNECTION DIAGRAM

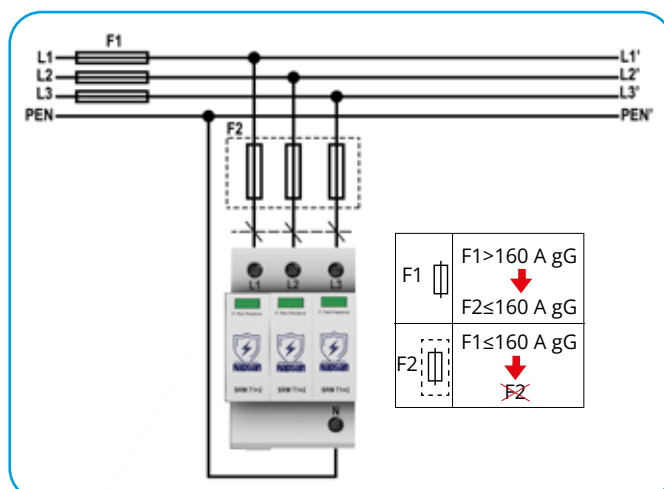



- High level protection is provided by hybrid technology in which varistors and GDT are used together.
- Thanks to its compact design, SPD can be used easily even in the narrowest panels.
- Low maintenance cost thanks to modular design.
- Fault status can be monitored with the indicators on the SPD.
- With the dry contact output, the fault status can be monitored remotely.
- Designed and manufactured in Türkiye.
- 5 years of warranty

2+0

TN-C

T1+T2 Class SPD according to EN 61643-11.

		SRG T1 2P V150	SRG T1 2P V275	SRG T1 2P V320
Electrical Features				
Nominal AC Voltage (50/60Hz)	Un	130V	240V	300V
Max. Continuous Operating Voltage (L-N)	Uc	150V	275V	320V
Nominal discharge current (8/20µs)	In		12,5 kA	
Max. discharge current (8/20µs)	I _{max}		60 kA	
Lightning impulse current (10/350µs)	I _{imp}		12,5 kA	
Voltage protection level	Up	≤1 kV	≤1,5 kV	≤1,5 kV
Response time	t _A		≤25ns	
Max. backup fuse			125 A gL/gG	
TOV withstand 5s.	UT	175V	337V	403V
TOV 120m.	UT	229V	442V	529V
Mechanical Features				
Operating temperature range	T _a		-40 C° to +80 C°	
Humidity	RH		5%...%90	
Tightening Torque	M _{max}		4,5 Nm	
Cable Cross-sectional area (max.)			35 mm ² Solid / Stranded / 25 mm ² Flexible	
For mounting on			35 mm DIN Rail EN 60715	
Casing Material			Thermoplastic, UL 94 V-0	
Degree of protection			IP20	
Specific Features				
Modular			YES	
Fault Indicators			Green for ok / Red for fault	
Remote Fault Signaling			YES	
Thermal Protection			YES	
Warranty			5 YEARS	



CIRCUIT DIAGRAM

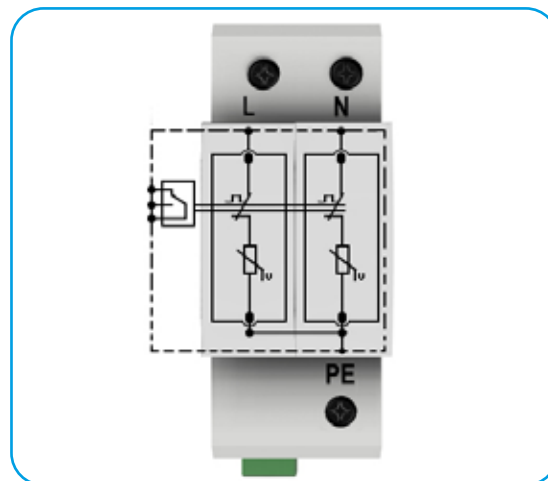

DIMENSIONS

Product Weight:	230 gr
Packaged Weight:	250 gr
Package Dimensions (ExBxY)	40x100x75 mm.

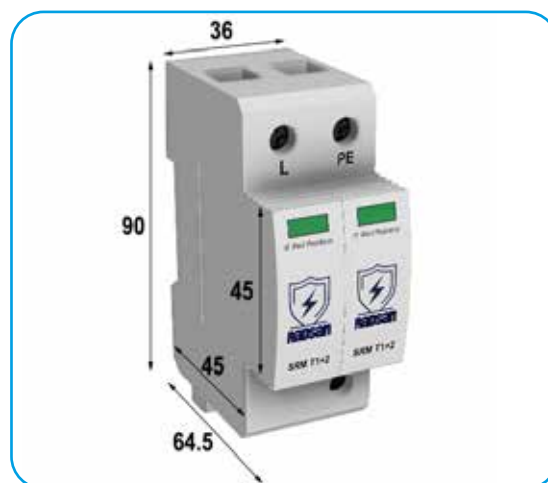

CONNECTION DIAGRAM

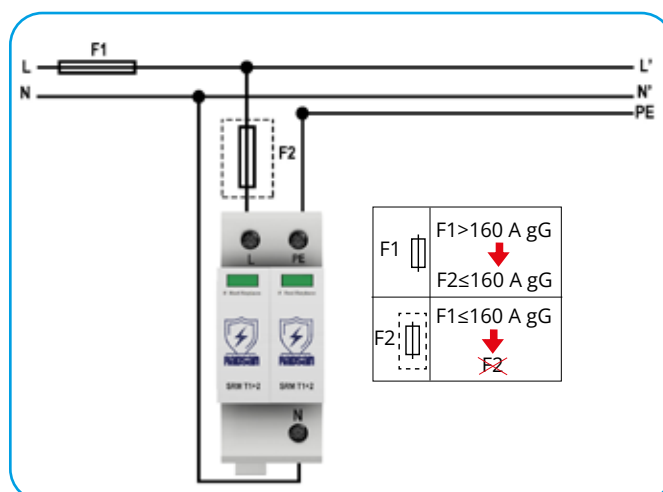



- High level protection is provided by hybrid technology in which varistors and GDT are used together.
- Thanks to its compact design, SPD can be used easily even in the narrowest panels.
- Low maintenance cost thanks to modular design.
- Fault status can be monitored with the indicators on the SPD.
- With the dry contact output, the fault status can be monitored remotely.
- Designed and manufactured in Turkiye.
- 5 years of warranty

1+0

T1+T2 Class SPD according to EN 61643-11.

		SRG T1 P V150	SRG T1 P V275	SRG T1 P V320
Electrical Features				
Nominal AC Voltage (50/60Hz)	Un	130V	240V	300V
Max. Continuous Operating Voltage (L-N)	Uc	150V	275V	320V
Nominal discharge current (8/20µs)	In	12,5 kA		
Max. discharge current (8/20µs)	I _{max}	60 kA		
Lightning impulse current (10/350µs)	I _{imp}	12,5 kA		
Voltage protection level	Up	≤1 kV	≤1,5 kV	≤1,5 kV
Response time	tA	≤25ns		
Max. backup fuse		125 A gL/gG		
TOV withstand 5s.	UT	175V	337V	403V
TOV 120m.	UT	229V	442V	529V
Mechanical Features				
Operating temperature range	Ta	-40 C° to +80 C°		
Humidity	RH	5%...%90		
Tightening Torque	M _{max}	4,5 Nm		
Cable Cross-sectional area (max.)		35 mm ² Solid / Stranded / 25 mm ² Flexible		
For mounting on		35 mm DIN Rail EN 60715		
Casing Material		Thermoplastic, UL 94 V-0		
Degree of protection		IP20		
Specific Features				
Modular		YES		
Fault Indicators		Green for ok / Red for fault		
Remote Fault Signaling		YES		
Thermal Protection		YES		
Warranty		5 YEARS		



CIRCUIT DIAGRAM

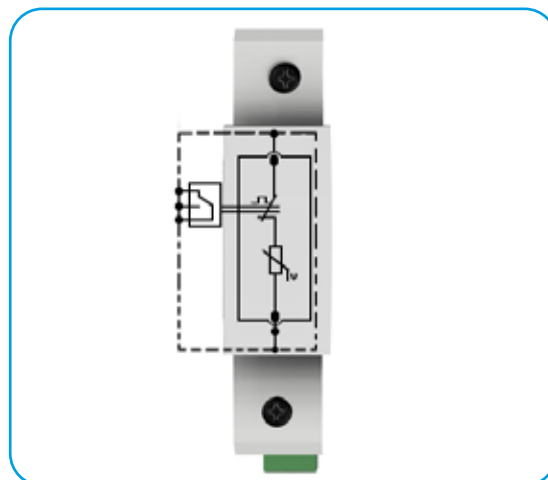

DIMENSIONS

Product Weight:	140 gr
Packaged Weight:	160 gr
Package Dimensions (ExBxY)	20x100x75 mm.





- Superior protection is provided by high performance GDTs.
- Thanks to its compact design, SPD can be used easily even in the narrowest panels.
- Fault status can be monitored with the indicators on the SPD.
- With the dry contact output, the fault status can be monitored remotely.
- Designed and manufactured in Turkiye.
- 5 years of warranty

3+1 TT TN-S

**T1 Class SPD according to EN 61643-11.
Combination: 3+1, TT and TN-S Network**

		SRG T1 150 3+1	SRG T1 255 3+1	SRG T1 275 3+1
Electrical Features				
Nominal AC Voltage (50/60Hz)	Un	130V	240 V	240 V
Max. Continuous Operating Voltage (N-PE)	Uc	150V	255 V	275 V
Lightning impulse current (10/350µs)	limp	25 kA (L-N) / 100 kA (N-PE)		
Voltage protection level	Up	≤1,5 kV	≤1,5 kV	≤2,5 kV
Response time	tA	≤100ns		
Max. backup fuse		500 A gL/gG		
Temporary overvoltage- 120 min. (L-N)	UT	230 V	440 V	530 V
Follow current extinguishing capability (N-PE)	Ifi	50 kA _{RMS}		
Mechanical Features				
Operating temperature range	Ta	-40 C° to +80 C°		
Humidity	RH	5%...%90		
Tightening Torque	Mmax	4,5 Nm		
Cable Cross-sectional area (max.)		10-35 mm ² Solid / Stranded / Fleksible		
For mounting on		35 mm DIN Rail EN 60715		
Casing Material		Thermoplastic, UL 94 V-0		
Degree of protection		IP20		
Specific Features				
Modular		NO		
Fault Indicators		Green for ok / Red for fault		
Remote Fault Signaling		YES		
Thermal Protection		YES		
Warranty		5 YEARS		



CIRCUIT DIAGRAM

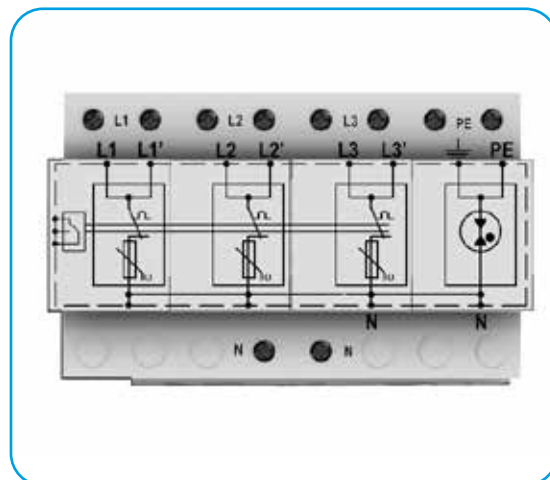

DIMENSIONS

Product Weight:	1075 gr
Packaged Weight:	1120 gr
Package Dimensions (ExBxY)	80x150x105 mm.

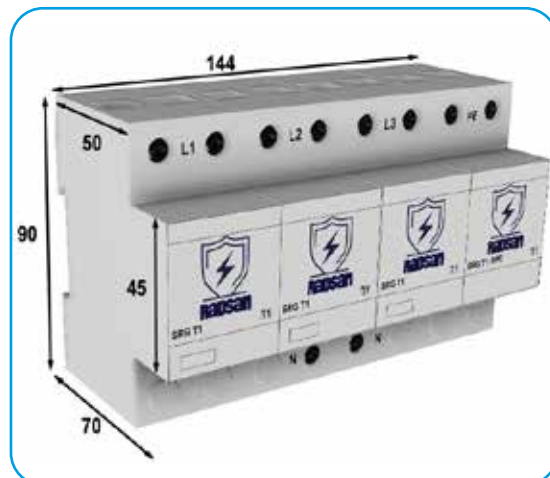

CONNECTION DIAGRAM

Series

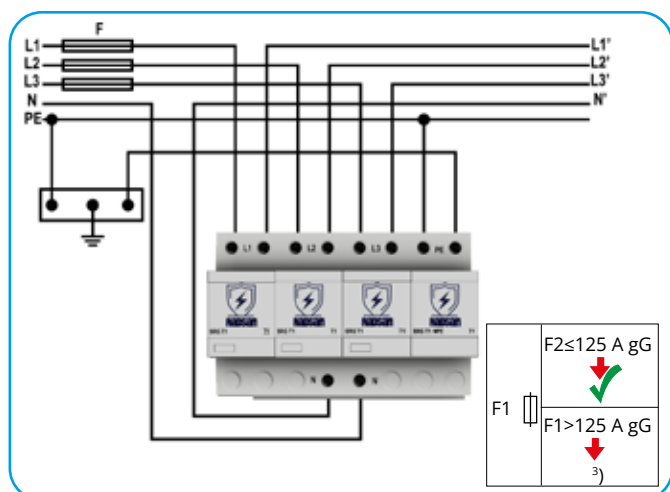

Parallel

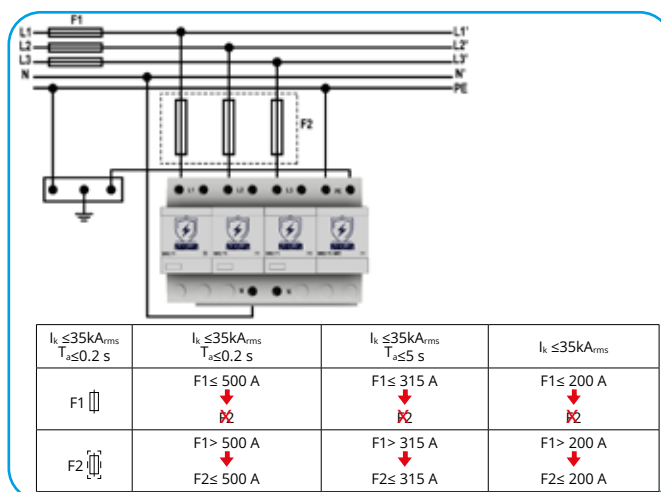



- Superior protection is provided by high performance GDTs.
- Thanks to its compact design, SPD can be used easily even in the narrowest panels.
- Fault status can be monitored with the indicators on the SPD.
- With the dry contact output, the fault status can be monitored remotely.
- Designed and manufactured in Turkiye.
- 5 years of warranty

1+1
**TT
TN-S**
T1 Class SPD according to EN 61643-11.
SRG T1 150 1+1
SRG T1 255 1+1
SRG T1 275 1+1
Electrical Features

		SRG T1 150 1+1	SRG T1 255 1+1	SRG T1 275 1+1
Nominal AC Voltage (50/60Hz)	Un	130V	240 V	240 V
Max. Continuous Operating Voltage (L-N)	Uc	150V	255 V	275 V
Lightning impulse current (10/350µs)	Iimp	25 kA (L-N) / 100 kA (N-PE)		
Voltage protection level	Up	≤1,5 kV	≤1,5 kV	≤2,5 kV
Response time	tA	≤100ns		
Max. backup fuse		500 A gL/gG		
Temporary overvoltage- 120 min. (L-N)	UT	230 V	440 V	530 V
Follow current extinguishing capability (N-PE)	I _{fi}	50 kA _{RMS}		

Mechanical Features

Operating temperature range	Ta	-40 C° to +80 C°		
Humidity	RH	5%...%90		
Tightening Torque	Mmax	4,5 Nm		
Cable Cross-sectional area (max.)		10-35 mm ² Solid / Stranded / Fleksible		
For mounting on		35 mm DIN Rail EN 60715		
Casing Material		Thermoplastic, UL 94 V-0		
Degree of protection		IP20		

Specific Features

Modular		HAYIR		
Fault Indicators		Green for ok / Red for fault		
Remote Fault Signaling		YES		
Thermal Protection		YES		
Warranty		5 YEARS		



CIRCUIT DIAGRAM

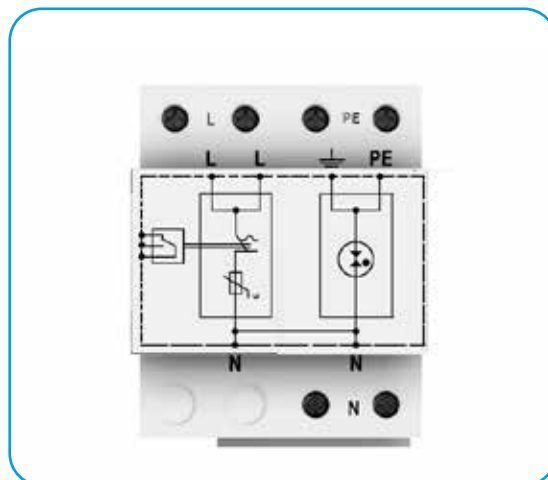

DIMENSIONS

Product Weight:	500 gr
Packaged Weight:	525 gr
Package Dimensions (ExBxY)	80x70x105 mm.

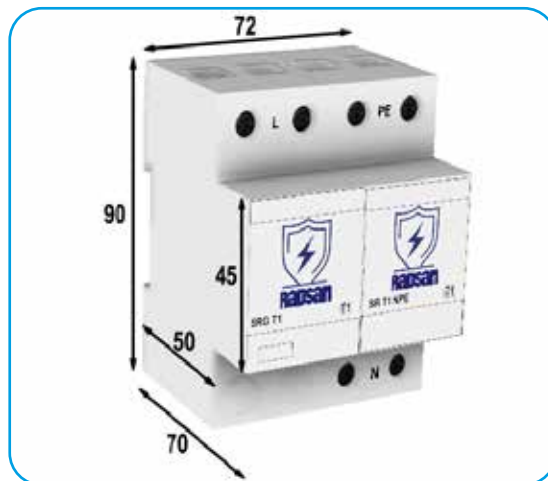

CONNECTION DIAGRAM

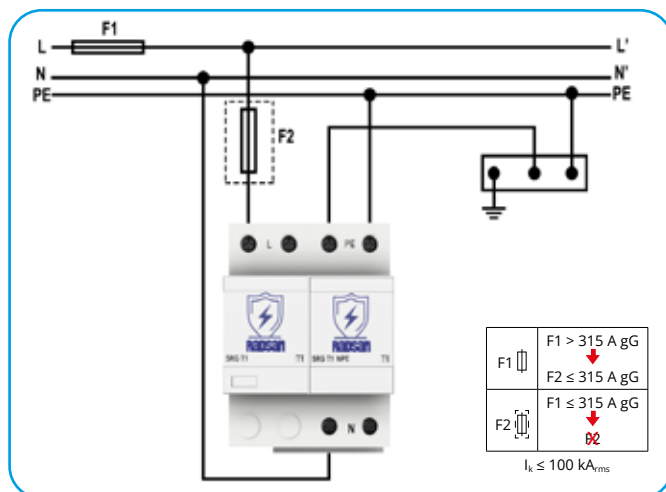
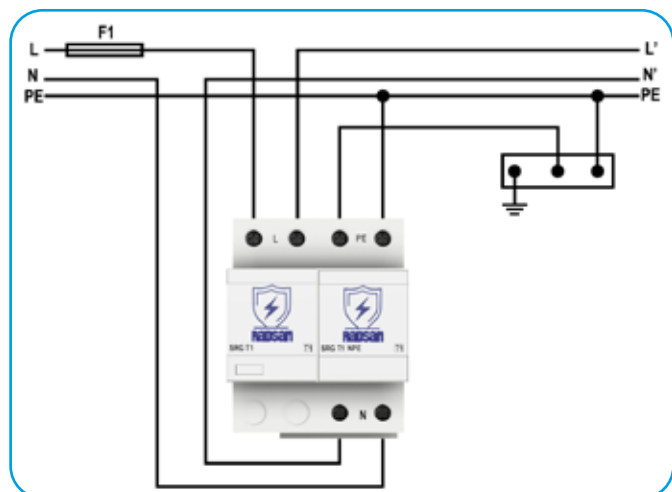



- Superior protection is provided by high performance GDTs.
- Thanks to its compact design, SPD can be used easily even in the narrowest panels.
- Fault status can be monitored with the indicators on the SPD.
- With the dry contact output, the fault status can be monitored remotely.
- Designed and manufactured in Turkiye.
- 5 years of warranty

4+0
TN-S

T1 Class SPD according to EN 61643-11.

		SRG T1 150 4+0	SRG T1 255 4+0	SRG T1 275 4+0
Electrical Features				
Nominal AC Voltage (50/60Hz)	Un	130V	240 V	240 V
Max. Continuous Operating Voltage (L-N)	Uc	150V	255 V	275 V
Lightning impulse current (10/350µs)	Iimp	50 kA		
Voltage protection level	Up	≤1,5 kV	≤2,5 kV	≤2,5 kV
Response time	tA	≤100ns		
Max. backup fuse		500 A gL/gG		
Temporary overvoltage- 120 min. (L-N)	UT	230 V	440 V	530 V
Follow current extinguishing capability (N-PE)	I _{fi}	50 kA _{RMS}		
Mechanical Features				
Operating temperature range	Ta	-40 C° to +80 C°		
Humidity	RH	5%...%90		
Tightening Torque	Mmax	4,5 Nm		
Cable Cross-sectional area (max.)		10-35 mm ² Solid / Stranded / Fleksible		
For mounting on		35 mm DIN Rail EN 60715		
Casing Material		Thermoplastic, UL 94 V-0		
Degree of protection		IP20		
Specific Features				
Modular		HAYIR		
Fault Indicators		Green for ok / Red for fault		
Remote Fault Signaling		YES		
Thermal Protection		YES		
Warranty		5 YEARS		



CIRCUIT DIAGRAM

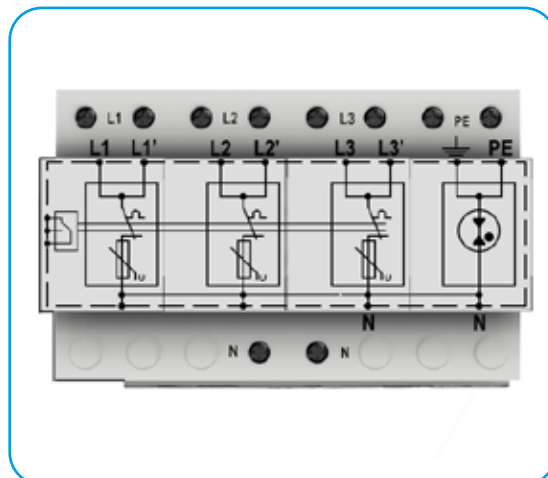

DIMENSIONS

Product Weight:	1075 gr
Packaged Weight:	1120 gr
Package Dimensions (ExBxY)	80x150x105 mm.



CONNECTION DIAGRAM

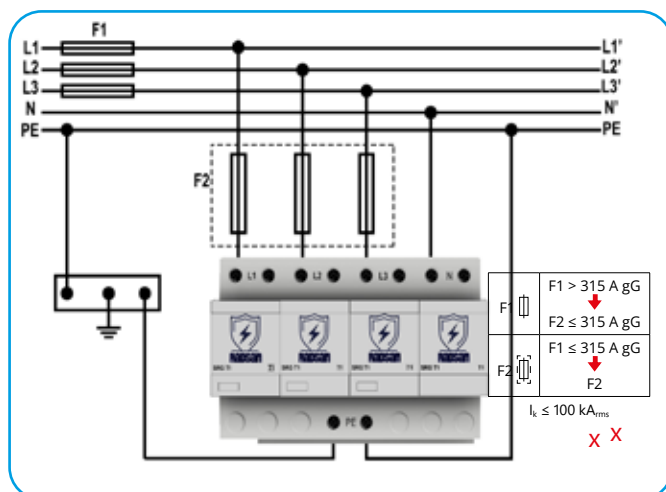
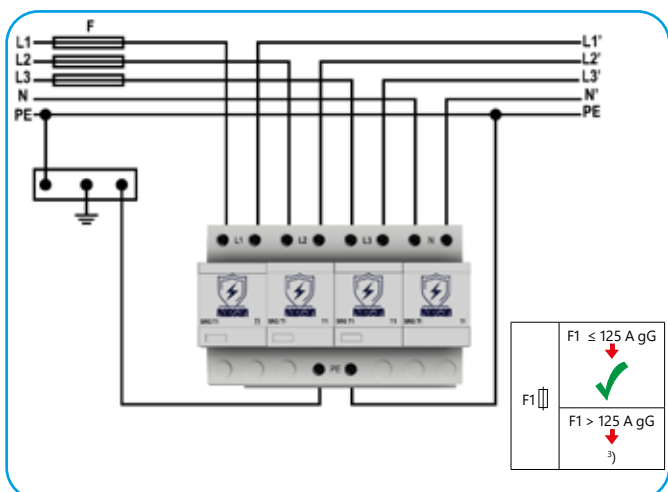



Superior protection is provided by high performance GDTs.

- Kompakt tasarım sayesinde en dar panolarda bile rahatça kullanılabilir.
- Fault status can be monitored with the indicators on the SPD.
- With the dry contact output, the fault status can be monitored remotely.
- Designed and manufactured in Türkiye.
- 5 years of warranty

3+0

TN-C

T1 Class SPD according to EN 61643-11.

		SRG T1 150 3+0	SRG T1 255 3+0	SRG T1 275 3+0
Electrical Features				
Nominal AC Voltage (50/60Hz)	Un	130V	240 V	240 V
Max. Continuous Operating Voltage (L-N)	Uc	150V	255 V	275 V
Lightning impulse current (10/350µs)	Iimp	50 kA		
Voltage protection level	Up	≤1,5 kV	≤2,5 kV	≤2,5 kV
Response time	tA	≤100ns		
Max. backup fuse		500 A gL/gG		
Temporary overvoltage- 120 min. (L-N)	UT	230 V	440 V	530 V
Follow current extinguishing capability (N-PE)	I _{fi}	50 kA _{RMS}		
Mechanical Features				
Operating temperature range	Ta	-40 C° to +80 C°		
Humidity	RH	5%...%90		
Tightening Torque	Mmax	4,5 Nm		
Cable Cross-sectional area (max.)		10-35 mm ² Solid / Stranded / Fleksible		
For mounting on		35 mm DIN Rail EN 60715		
Casing Material		Thermoplastic, UL 94 V-0		
Degree of protection		IP20		
Specific Features				
Modular		HAYIR		
Fault Indicators		Green for ok / Red for fault		
Remote Fault Signaling		YES		
Thermal Protection		YES		
Warranty		5 YEARS		



CIRCUIT DIAGRAM

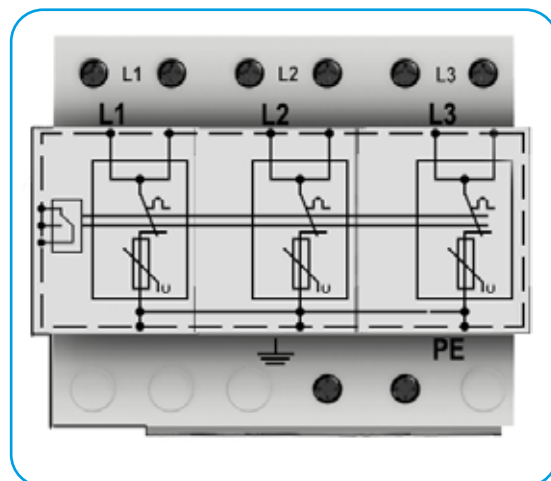

DIMENSIONS

Product Weight:	810 gr
Packaged Weight:	845 gr
Package Dimensions (ExBxY)	80x105x105 mm.

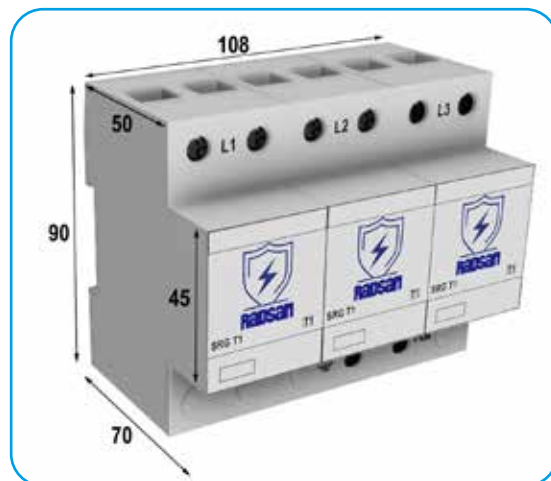

CONNECTION DIAGRAM

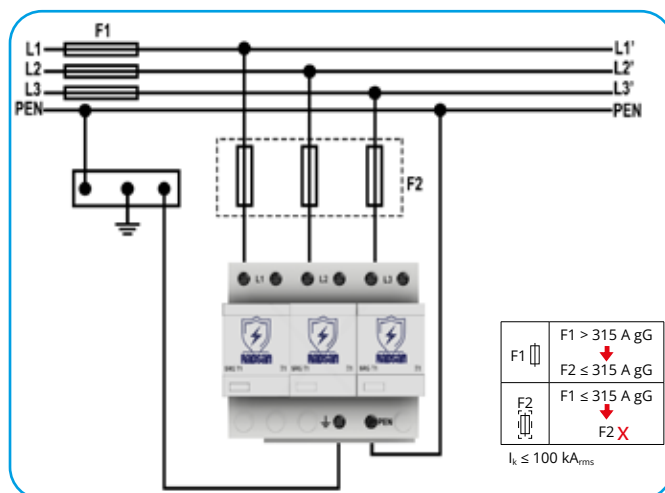
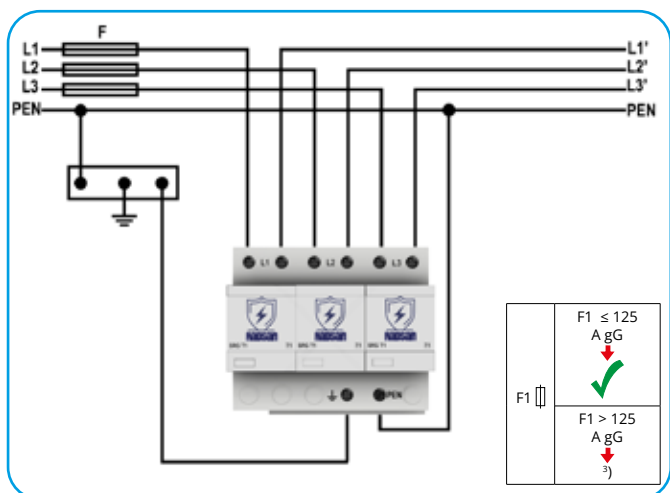



Superior protection is provided by high performance GDTs.

- Kompakt tasarım sayesinde en dar panolarda bile rahatça kullanılabilir.
- Fault status can be monitored with the indicators on the SPD.
- With the dry contact output, the fault status can be monitored remotely.
- Designed and manufactured in Türkiye.
- 5 years of warranty

2+0

TN-C

T1 Class SPD according to EN 61643-11.

SRG T1 150 2+0

SRG T1 255 2+0

SRG T1 275 2+0

Electrical Features

		SRG T1 150 2+0	SRG T1 255 2+0	SRG T1 275 2+0
Nominal AC Voltage (50/60Hz)	Un	130V	240 V	240 V
Max. Continuous Operating Voltage (L-N)	Uc	150V	255 V	275 V
Lightning impulse current (10/350µs)	Iimp	50 kA		
Voltage protection level	Up	≤1,5 kV	≤2,5 kV	≤2,5 kV
Response time	tA	≤100ns		
Max. backup fuse		500 A gL/gG		
Temporary overvoltage- 120 min. (L-N)	UT	230 V	440 V	530 V
Follow current extinguishing capability (N-PE)	I _{fi}	50 kA _{RMS}		

Mechanical Features

Operating temperature range	Ta	-40 C° to +80 C°		
Humidity	RH	5%....%90		
Tightening Torque	Mmax	4,5 Nm		
Cable Cross-sectional area (max.)		10-35 mm ² Solid / Stranded / Fleksible		
For mounting on		35 mm DIN Rail EN 60715		
Casing Material		Thermoplastic, UL 94 V-0		
Degree of protection		IP20		

Specific Features

Modular		HAYIR		
Fault Indicators		Green for ok / Red for fault		
Remote Fault Signaling		YES		
Thermal Protection		YES		
Warranty		5 YEARS		



CIRCUIT DIAGRAM

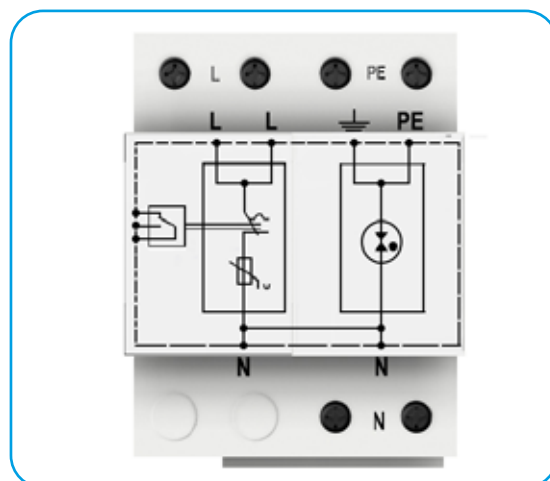

DIMENSIONS

Product Weight:	500 gr
Packaged Weight:	525 gr
Package Dimensions (ExBxY)	80x70x105 mm.

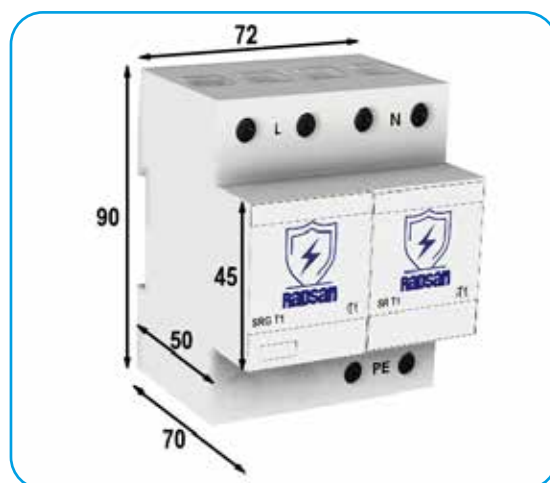

CONNECTION DIAGRAM

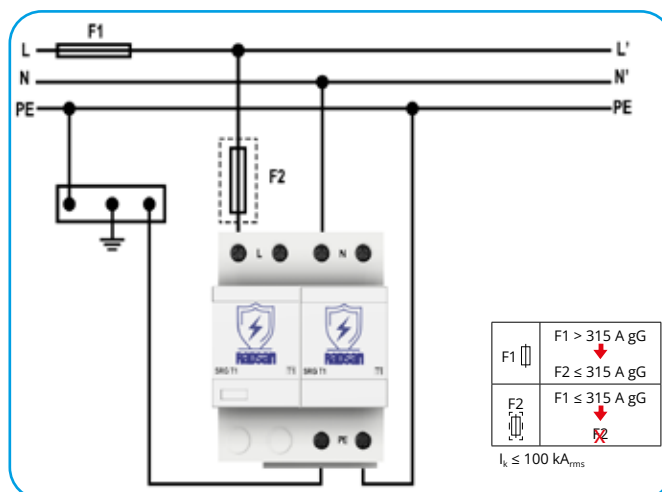
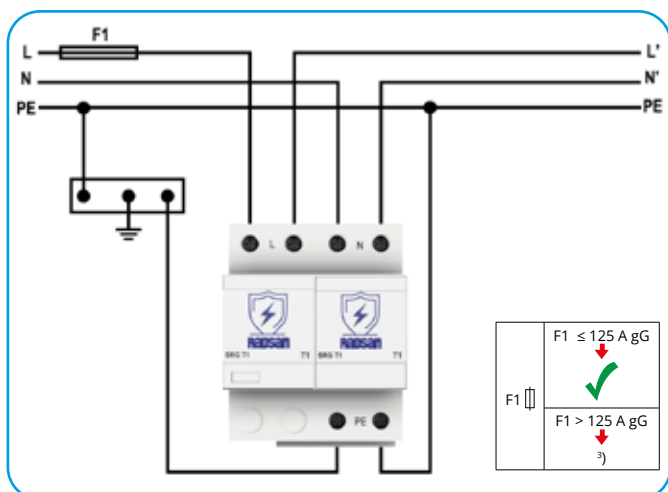



- Superior protection is provided by high performance GDTs.
- Thanks to its compact design, SPD can be used easily even in the narrowest panels.
- Fault status can be monitored with the indicators on the SPD.
- With the dry contact output, the fault status can be monitored remotely.
- Designed and manufactured in Turkiye.
- 5 years of warranty

1+0**TN-C**

T1 Class SPD according to EN 61643-11.

		SRG T1 150 1+0	SRG T1 255 1+0	SRG T1 275 1+0
Electrical Features				
Nominal AC Voltage (50/60Hz)	Un	130V	240 V	240 V
Max. Continuous Operating Voltage (L-N)	Uc	150V	255 V	275 V
Lightning impulse current (10/350µs)	Iimp	50 kA		
Voltage protection level	Up	≤1,5 kV	≤2,5 kV	≤2,5 kV
Response time	tA	≤100ns		
Max. backup fuse		500 A gL/gG		
Temporary overvoltage- 120 min. (L-N)	UT	230 V	440 V	530 V
Follow current extinguishing capability (N-PE)	I _{fi}	50 kA _{RMS}		
Mechanical Features				
Operating temperature range	Ta	-40 C° to +80 C°		
Humidity	RH	5%...%90		
Tightening Torque	Mmax	4,5 Nm		
Cable Cross-sectional area (max.)		10-35 mm ² Solid / Stranded / Fleksible		
For mounting on		35 mm DIN Rail EN 60715		
Casing Material		Thermoplastic, UL 94 V-0		
Degree of protection		IP20		
Specific Features				
Modular		HAYIR		
Fault Indicators		Green for ok / Red for fault		
Remote Fault Signaling		YES		
Thermal Protection		YES		
Warranty		5 YEARS		



CIRCUIT DIAGRAM

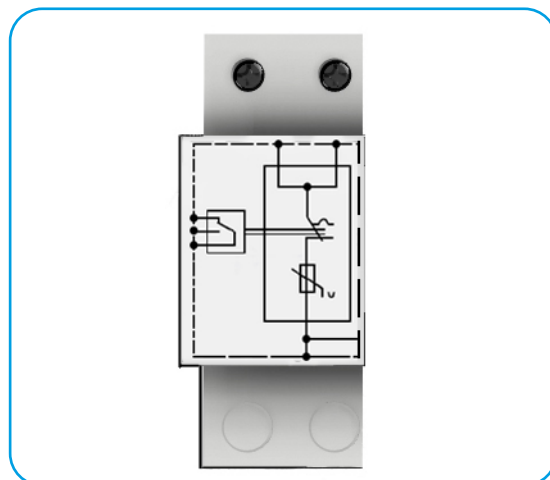

DIMENSIONS

Product Weight:	290 gr
Packaged Weight:	310 gr
Package Dimensions (ExBxY)	80x40x105 mm.

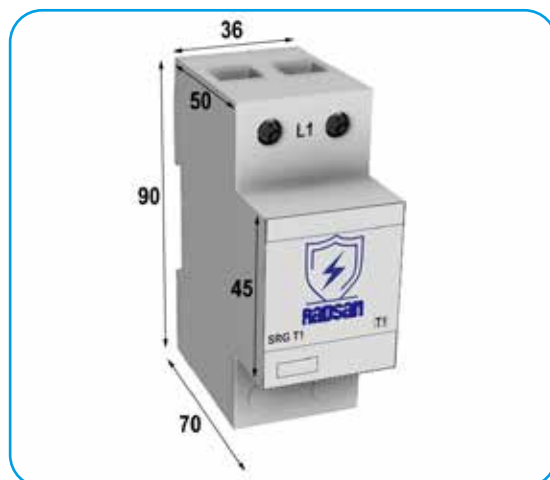



- Superior protection is provided by high performance varistors.
- Thanks to its compact design, SPD can be used easily even in the narrowest panels.
- Low maintenance cost thanks to modular design.
- Fault status can be monitored with the indicators on the SPD.
- With the dry contact output, the fault status can be monitored remotely.
- Designed and manufactured in Türkiye.
- 5 years of warranty
- **TUV certified**

**T2 Class SPD according to EN 61643-11.
Combination: 3+1, TT and TN-S Network**



SRG T2 3+1 150 | SRG T2 3+1 275 | SRG T2 3+1 320 | SRG T2 3+1 385

Electrical Features					
Nominal AC Voltage (50/60Hz)	Un	120 V	230 V	230 V	230 V
Max. Continuous Operating Voltage (L-N)	Uc	150 V	275 V	320 V	385 V
En Yüksek Sürekli Çalışma AC Gerilimi (N-PE)	Uc	255 V	255 V	255 V	255 V
Nominal discharge current (8/20µs)	In	20 kA			
Max. discharge current (8/20µs)	Imax	40 kA			
Voltage protection level (L-N)	Up	≤0,7 kV	≤1,3 kV	≤1,5 kV	≤1,8 kV
Voltage protection level (L-N) at 5 kA	Up	≤0,55 kV	≤1 kV	≤1,2 kV	≤1,4 kV
Voltage protection level (N-PE)	Up	≤1,5 kV	≤1,5 kV	≤1,5 kV	≤1,5 kV
Response time	tA	≤25ns / ≤100ns			
Max. backup fuse		125 A gL/gG			
TOV- 5s. (L-N)		175 V	335 V	335 V	335 V
Temporary overvoltage- 120 min. (L-N)	UT	235 V	440 V	440 V	440 V
Temporary overvoltage-200 ms (N-PE)	UT	1200 V			
Follow current extinguishing capability (N-PE)	Ifi	100 A _{RMS}			

Mechanical Features		
Operating temperature range	Ta	-40 C° to +80 C°
Humidity	RH	5%...%90
Tightening Torque	Mmax	4,5 Nm
Cable Cross-sectional area (max.)		35 mm ² Solid / Stranded / 25 mm ² Flexible
For mounting on		35 mm DIN Rail EN 60715
Casing Material		Thermoplastic, UL 94 V-0
Degree of protection		IP20

Specific Features		
Modular		YES
Fault Indicators		Green for ok / Red for fault
Remote Fault Signaling		YES
Thermal Protection		YES
Warranty		5 YEARS



CIRCUIT DIAGRAM

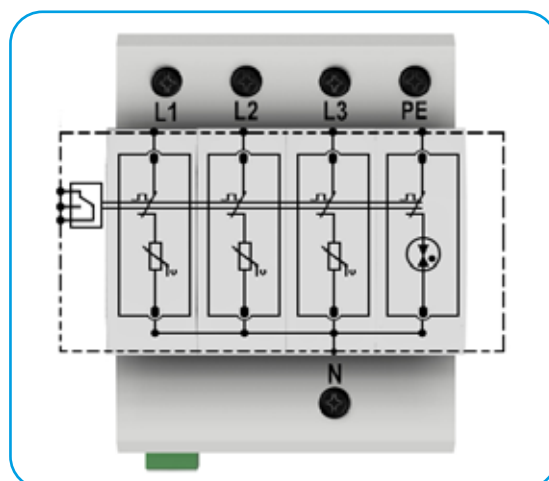

DIMENSIONS

Product Weight:	355 gr
Packaged Weight:	385 gr
Package Dimensions (ExBxY)	75x100x77 mm.

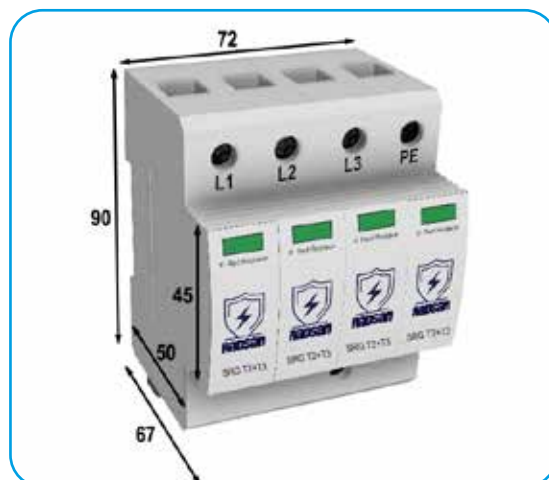

CONNECTION DIAGRAM

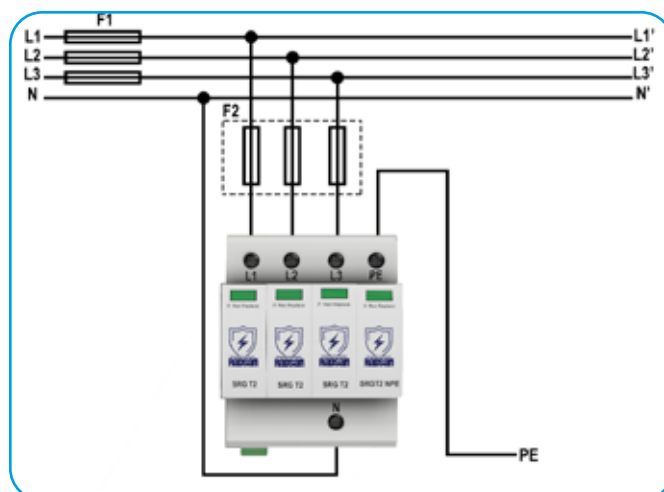
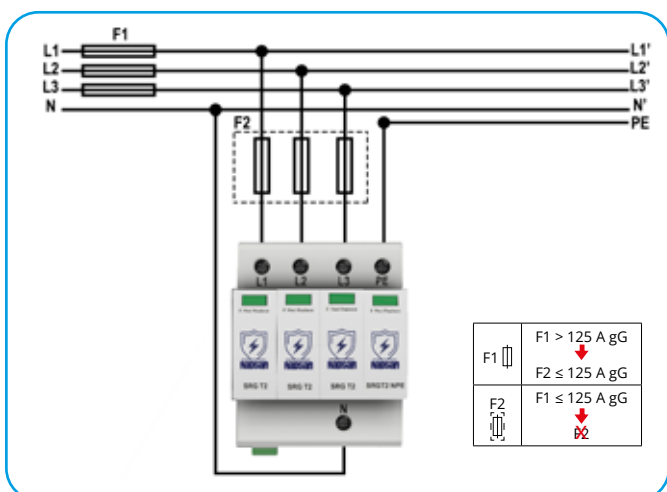



- Superior protection is provided by high performance varistors.
- Thanks to its compact design, SPD can be used easily even in the narrowest panels.
- Low maintenance cost thanks to modular design.
- Fault status can be monitored with the indicators on the SPD.
- With the dry contact output, the fault status can be monitored remotely.
- Designed and manufactured in Türkiye.
- 5 years of warranty
- **TUV certificated**



T2 Class SPD according to EN 61643-11.

		SRG T2 1+1 275	SRG T2 1+1 320	SRG T2 1+1 385
Electrical Features				
Nominal AC Voltage (50/60Hz)	Un	230 V	230 V	230 V
Max. Continuous Operating Voltage (L-N)	Uc	275 V	320 V	385 V
En Yüksek Sürekli Çalışma AC Gerilimi (N-PE)	Uc	255 V	255 V	255 V
Nominal discharge current (8/20µs)	In	20 kA		
Max. discharge current (8/20µs)	I _{max}	40 kA		
Voltage protection level (L-N)	Up	≤1,3 kV	≤1,5 kV	≤1,8 kV
Voltage protection level (L-N) at 5 kA	Up	≤1 kV	≤1,2 kV	≤1,4 kV
Voltage protection level (N-PE)	Up	≤1,5 kV	≤1,5 kV	≤1,5 kV
Response time	t _A	≤25ns / ≤100ns		
Max. backup fuse		125 A gL/gG		
TOV- 5s. (L-N)		335 V	335 V	335 V
Temporary overvoltage- 120 min. (L-N)	UT	440 V	440 V	440 V
Temporary overvoltage-200 ms (N-PE)	UT	1200 V		
Follow current extinguishing capability (N-PE)	I _{fi}	100 A _{RMS}		
Mechanical Features				
Operating temperature range	T _a	-40 C° to +80 C°		
Humidity	RH	5%...%90		
Tightening Torque	M _{max}	4,5 Nm		
Cable Cross-sectional area (max.)		35 mm ² Solid / Stranded / 25 mm ² Flexible		
For mounting on		35 mm DIN Rail EN 60715		
Casing Material		Thermoplastic, UL 94 V-0		
Degree of protection		IP20		
Specific Features				
Modular		YES		
Fault Indicators		Green for ok / Red for fault		
Remote Fault Signaling		YES		
Thermal Protection		YES		
Warranty		5 YEARS		



CIRCUIT DIAGRAM

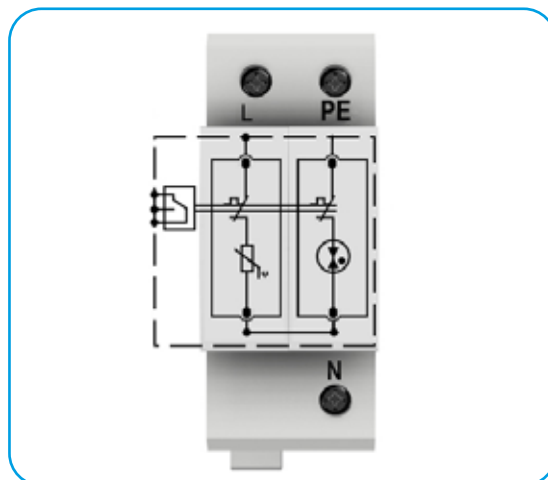

DIMENSIONS

Product Weight:	180 gr
Packaged Weight:	200 gr
Package Dimensions (ExBxY)	40x100x77 mm.



CONNECTION DIAGRAM

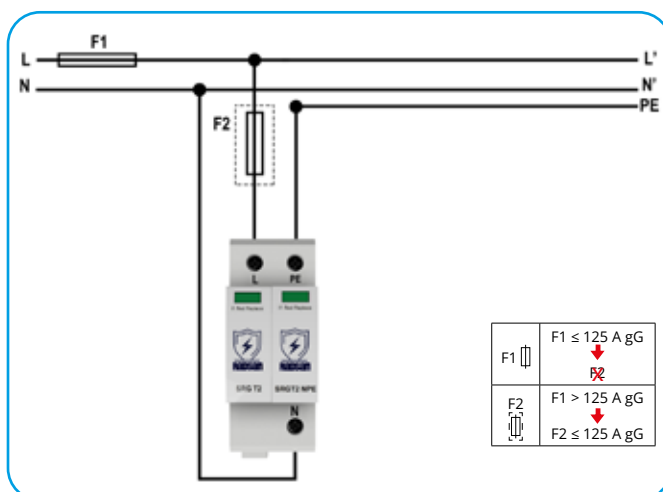



- Superior protection is provided by high performance varistors.
- Thanks to its compact design, SPD can be used easily even in the narrowest panels.
- Low maintenance cost thanks to modular design.
- Fault status can be monitored with the indicators on the SPD.
- With the dry contact output, the fault status can be monitored remotely.
- Designed and manufactured in Türkiye.
- 5 years of warranty
- **TUV certificated**



T2 Class SPD according to EN 61643-11.

		SRG T2 4P 150	SRG T2 4P 275	SRG T2 4P 320	SRG T2 4P 385
Electrical Features					
Nominal AC Voltage (50/60Hz)	Un	120V	230 V	230 V	230 V
Max. Continuous Operating Voltage (L-N)	Uc	150V	275 V	320 V	385 V
Nominal discharge current (8/20µs)	In	20 kA			
Max. discharge current (8/20µs)	Imax	40 kA			
Voltage protection level	Up	≤0,8 kV	≤1,3 kV	≤1,5 kV	≤1,8 kV
Voltage protection level at 5 kA	Up	≤0,6 kV	≤1 kV	≤1,2 kV	≤1,4 kV
Response time	tA	≤25ns			
Max. backup fuse		125 A gL/gG			
TOV- 5s.		175 V	335 V	335 V	335 V
TOV- 120 min	UT	235 V	440 V	440 V	440 V
Mechanical Features					
Operating temperature range	Ta	-40 C° to +80 C°			
Humidity	RH	5%...%90			
Tightening Torque	Mmax	4,5 Nm			
Cable Cross-sectional area (max.)		35 mm ² Solid / Stranded / 25 mm ² Flexible			
For mounting on		35 mm DIN Rail EN 60715			
Casing Material		Thermoplastic, UL 94 V-0			
Degree of protection		IP20			
Specific Features					
Modular		YES			
Fault Indicators		Green for ok / Red for fault			
Remote Fault Signaling		YES			
Thermal Protection		YES			
Warranty		5 YEARS			



CIRCUIT DIAGRAM

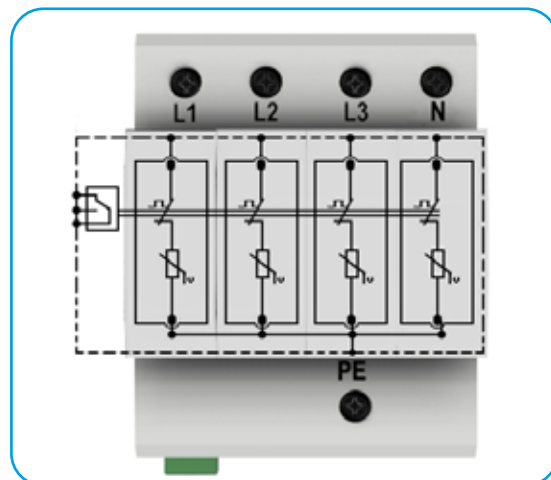

DIMENSIONS

Product Weight:	355 gr
Packaged Weight:	385 gr
Package Dimensions (ExBxY)	75x100x77 mm.

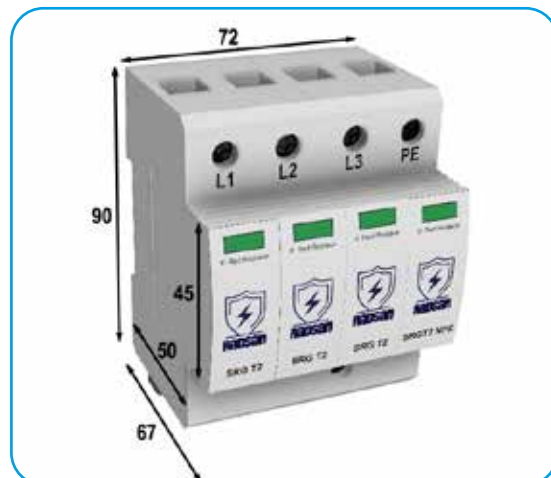

CONNECTION DIAGRAM

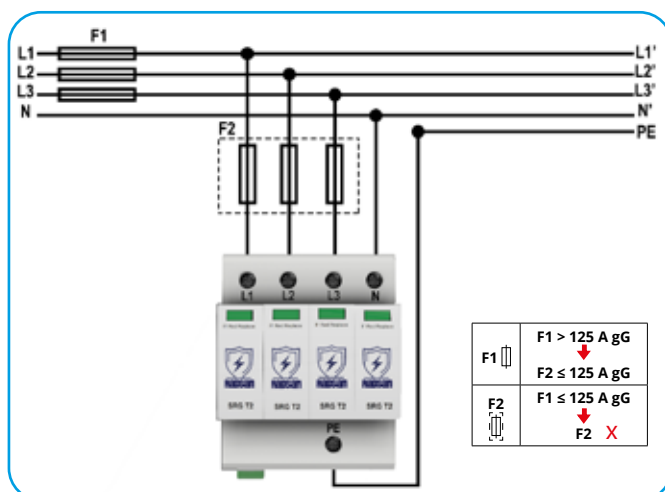



- Superior protection is provided by high performance varistors.
- Thanks to its compact design, SPD can be used easily even in the narrowest panels.
- Low maintenance cost thanks to modular design.
- Fault status can be monitored with the indicators on the SPD.
- With the dry contact output, the fault status can be monitored remotely.
- Designed and manufactured in Turkiye.
- 5 years of warranty
- **TUV certified**



T2 Class SPD according to EN 61643-11.

SRG T2 3P 150 SRG T2 3P 275 SRG T2 3P 320 SRG T2 3P 385

Electrical Features					
Nominal AC Voltage (50/60Hz)	Un	120V	230 V	230 V	230 V
Max. Continuous Operating Voltage (L-N)	Uc	150V	275 V	320 V	385 V
Nominal discharge current (8/20µs)	In	20 kA			
Max. discharge current (8/20µs)	I _{max}	40 kA			
Voltage protection level	Up	≤0,8 kV	≤1,3 kV	≤1,5 kV	≤1,8 kV
Voltage protection level at 5 kA	Up	≤0,6 kV	≤1 kV	≤1,2 kV	≤1,4 kV
Response time	t _A	≤25ns			
Max. backup fuse		125 A gL/gG			
TOV- 5s.		175 V	335 V	335 V	335 V
TOV- 120 min	UT	235 V	440 V	440 V	440 V

Mechanical Features		
Operating temperature range	Ta	-40 C° to +80 C°
Humidity	RH	5%...%90
Tightening Torque	M _{max}	4,5 Nm
Cable Cross-sectional area (max.)		35 mm ² Solid / Stranded / 25 mm ² Flexible
For mounting on		35 mm DIN Rail EN 60715
Casing Material		Thermoplastic, UL 94 V-0
Degree of protection		IP20

Specific Features		
Modular		YES
Fault Indicators		Green for ok / Red for fault
Remote Fault Signaling		YES
Thermal Protection		YES
Warranty		5 YEARS



CIRCUIT DIAGRAM

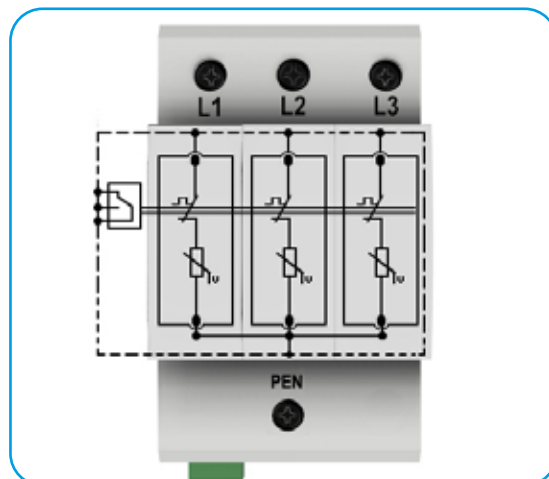

DIMENSIONS

Product Weight:	265 gr
Packaged Weight:	290 gr
Package Dimensions (ExBxY)	60x100x77 mm.



CONNECTION DIAGRAM

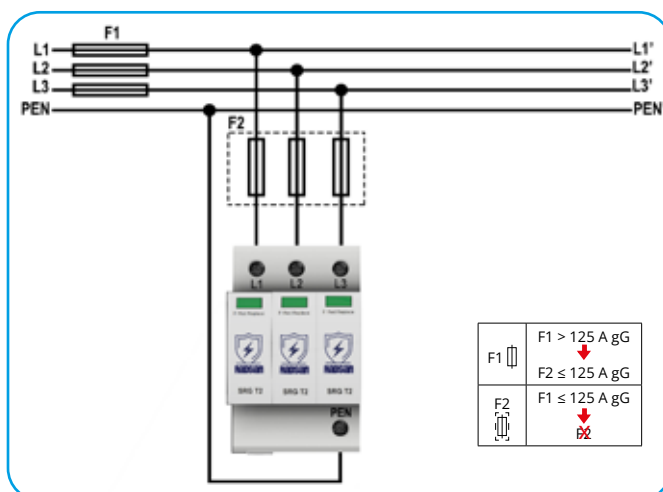



- Superior protection is provided by high performance varistors.
- Thanks to its compact design, SPD can be used easily even in the narrowest panels.
- Low maintenance cost thanks to modular design.
- Fault status can be monitored with the indicators on the SPD.
- With the dry contact output, the fault status can be monitored remotely.
- Designed and manufactured in Turkiye.
- 5 years of warranty
- **TUV certificated**



T2 Class SPD according to EN 61643-11.

		SRG T2 2P 150	SRG T2 2P 275	SRG T2 2P 320	SRG T2 2P 385
Electrical Features					
Nominal AC Voltage (50/60Hz)	Un	120V	230 V	230 V	230 V
Max. Continuous Operating Voltage (L-N)	Uc	150V	275 V	320 V	385 V
Nominal discharge current (8/20µs)	In	20 kA			
Max. discharge current (8/20µs)	I _{max}	40 kA			
Voltage protection level	Up	≤0,8 kV	≤1,3 kV	≤1,5 kV	≤1,8 kV
Voltage protection level at 5 kA	Up	≤0,6 kV	≤1 kV	≤1,2 kV	≤1,4 kV
Response time	t _A	≤25ns			
Max. backup fuse		125 A gL/gG			
TOV- 5s.		175 V	335 V	335 V	335 V
TOV- 120 min	UT	235 V	440 V	440 V	440 V

Mechanical Features		
Operating temperature range	T _a	-40 C° to +80 C°
Humidity	RH	5%....%90
Tightening Torque	M _{max}	4,5 Nm
Cable Cross-sectional area (max.)		35 mm ² Solid / Stranded / 25 mm ² Flexible
For mounting on		35 mm DIN Rail EN 60715
Casing Material		Thermoplastic, UL 94 V-0
Degree of protection		IP20

Specific Features		
Modular		YES
Fault Indicators		Green for ok / Red for fault
Remote Fault Signaling		YES
Thermal Protection		YES
Warranty		5 YEARS



CIRCUIT DIAGRAM

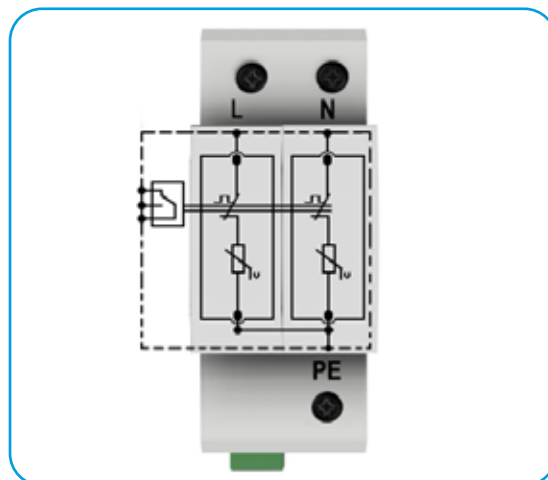

DIMENSIONS

Product Weight:	180 gr
Packaged Weight:	200 gr
Package Dimensions (ExBxY)	40x100x77 mm.



CONNECTION DIAGRAM

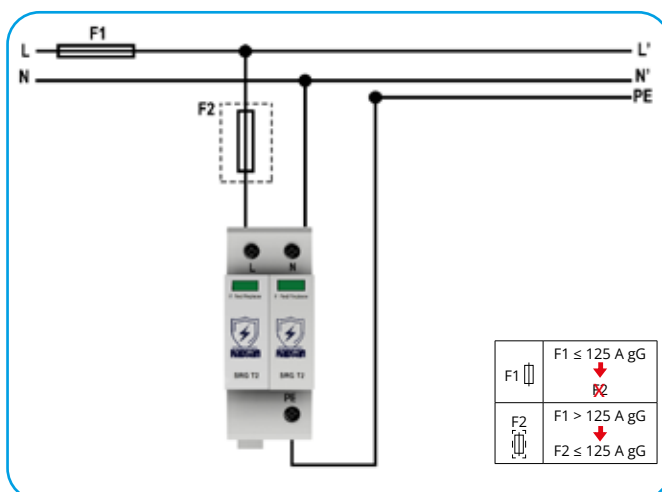



- Superior protection is provided by high performance varistors.
- Thanks to its compact design, SPD can be used easily even in the narrowest panels.
- Low maintenance cost thanks to modular design.
- Fault status can be monitored with the indicators on the SPD.
- With the dry contact output, the fault status can be monitored remotely.
- Designed and manufactured in Türkiye.
- 5 years of warranty
- **TUV certificated**



T2 Class SPD according to EN 61643-11.

SRG T2 1P 48V SRG T2 1P 75V SRG T2 1P 150V SRG T2 1P 275V SRG T2 1P 320V SRG T2 1P 385V

Electrical Features							
		SRG T2 1P 48V	SRG T2 1P 75V	SRG T2 1P 150V	SRG T2 1P 275V	SRG T2 1P 320V	SRG T2 1P 385V
Nominal AC Voltage (50/60Hz)	Un	42 V	60 V	120V	230 V	230 V	230 V
Max. Continuous Operating Voltage (L-N)	Uc	48 V	75 V	150V	275 V	320 V	385 V
En Yüksek Sürekli Çalışma DC Gerilimi	Uc	60 V	100 V	200 V	350 V	420 V	500 V
Nominal discharge current (8/20µs)	In	20 kA					
Max. discharge current (8/20µs)	Imax	40 kA					
Voltage protection level	Up	≤0,4 kV	≤0,5 kV	≤0,8 kV	≤1,3 kV	≤1,5 kV	≤1,8 kV
Voltage protection level at 5 kA	Up	≤0,3 kV	≤0,35 kV	≤0,6 kV	≤1 kV	≤1,2 kV	≤1,4 kV
Max. backup fuse		125 A gL/gG					
Response time	tA	≤25ns					
TOV- 5s.	UT	70 V	90 V	175 V	335 V	335 V	335 V
TOV- 120 min	UT	90 V	115 V	230 V	440 V	440 V	440 V
Mechanical Features							
Operating temperature range	Ta	-40 C° to +80 C°					
Humidity	RH	5%....%90					
Tightening Torque	Mmax	4,5 Nm					
Cable Cross-sectional area (max.)		35 mm ² Solid / Stranded / 25 mm ² Flexible					
For mounting on		35 mm DIN Rail EN 60715					
Casing Material		Thermoplastic, UL 94 V-0					
Degree of protection		IP20					
Specific Features							
Modular		YES					
Fault Indicators		Green for ok / Red for fault					
Remote Fault Signaling		YES					
Thermal Protection		YES					
Warranty		5 YEARS					



CIRCUIT DIAGRAM

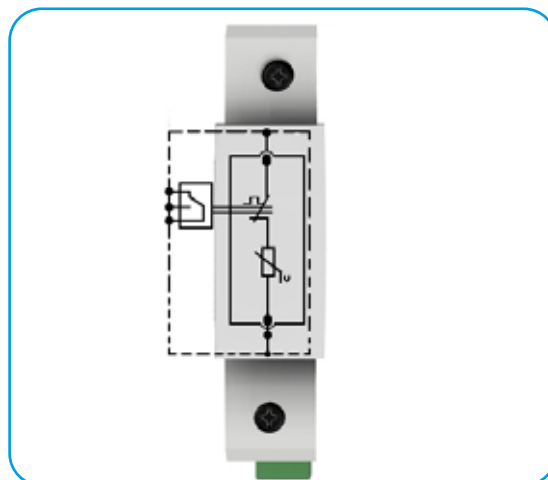

DIMENSIONS

Product Weight:	100 gr
Packaged Weight:	115 gr
Package Dimensions (ExBxY)	20x100x77 mm.





- Superior protection is provided by high performance varistors.
- Thanks to its compact design, SPD can be used easily even in the narrowest panels.
- Low maintenance cost thanks to modular design.
- Fault status can be monitored with the indicators on the SPD.
- With the dry contact output, the fault status can be monitored remotely.
- Designed and manufactured in Turkiye.
- 5 years of warranty

T2+3 Class SPD according to EN 61643-11.

Network Type	SRG T2+3 3+1 320		SRG T2+3 1+1 320		SRG T2+3 4+0 320		SRG T2+3 1+0 320	
	TT and TN-S		TT and TN-S		TN-S			
Electrical Features								
Nominal AC Voltage (50/60Hz)	Un	230 V/400 V		230 V/400 V		230 V/400 V		230 V/400 V
Max. Continuous Operating Voltage (L-N)	Uc	320 V		320 V		320 V		320 V
Nominal discharge current (8/20µs)	In	20 kA						
Max. discharge current (8/20µs)	I _{max}	40 kA						
Voltage protection level	Up	≤1,5 kV		≤1,5 kV		≤1,5 kV		≤1,5 kV
Kombine Darbe	Uoc	10 kV/5kA		10 kV/5kA		10 kV/5kA		10 kV/5kA
Max. backup fuse		125 A gL/gG						
Response time	t _A	≤25ns						
TOV- 5s.	U _T	337 V		337 V		337 V		337 V
TOV- 120 min	U _T	442 V		442 V		442 V		442 V
Mechanical Features								
Operating temperature range	T _a	-40 C° to +80 C°						
Humidity	RH	5%...%90						
Tightening Torque	M _{max}	4,5 Nm						
Cable Cross-sectional area (max.)		35 mm ² Solid / Stranded / 25 mm ² Flexible						
For mounting on		35 mm DIN Rail EN 60715						
Casing Material		Thermoplastic, UL 94 V-0						
Degree of protection		IP20						
Specific Features								
Modular		YES						
Fault Indicators		Green for ok / Red for fault						
Remote Fault Signaling		YES						
Thermal Protection		YES						
Warranty		5 YEARS						



CIRCUIT DIAGRAM

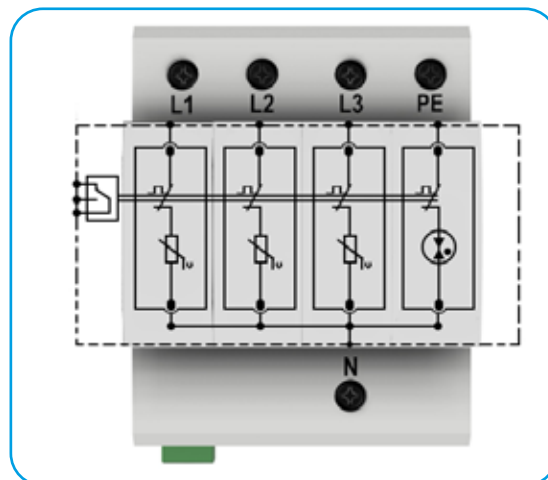

DIMENSIONS

Product Weight:	355 gr
Packaged Weight:	385 gr
Package Dimensions (ExBxY)	75x100x77 mm.

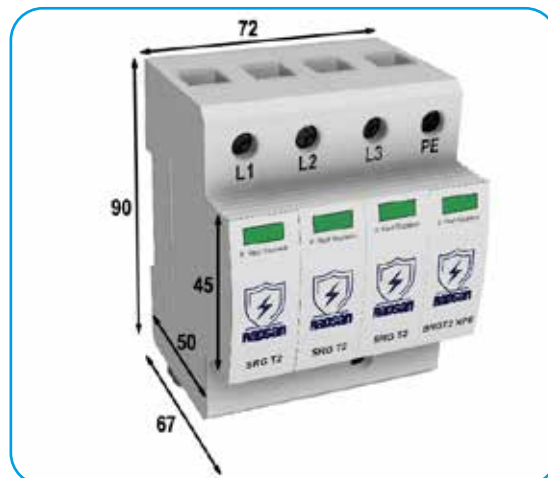

CONNECTION DIAGRAM

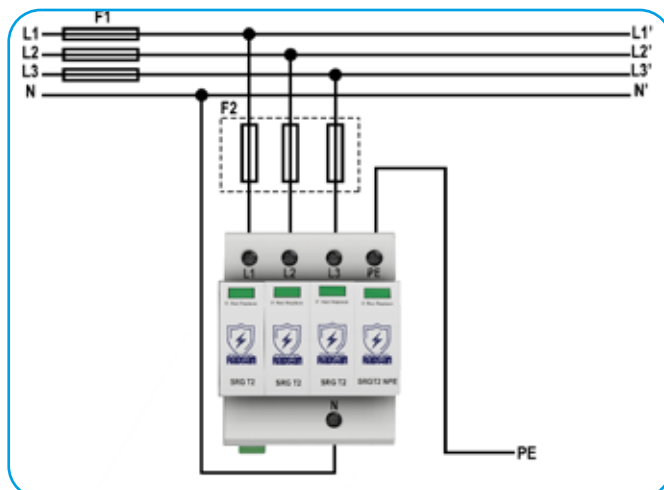
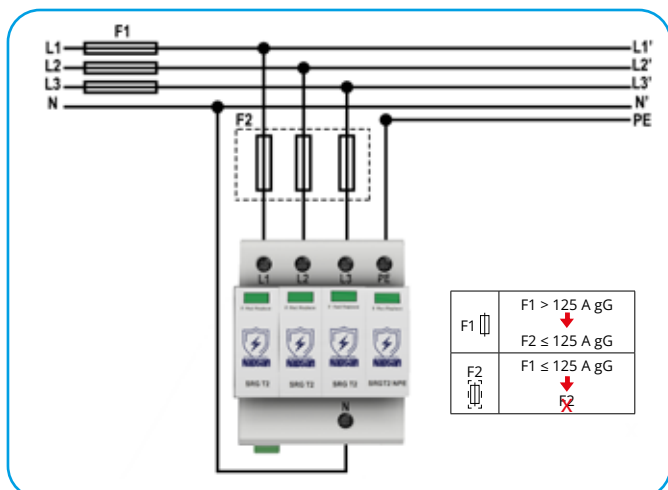



- Superior protection is provided by high performance varistors.
- Thanks to its compact design, SPD can be used easily even in the narrowest panels.
- Fault status can be monitored with the indicators on the SPD.
- With the dry contact output, the fault status can be monitored remotely.
- Designed and manufactured in Türkiye.
- 5 years of warranty

T3 Class SPD according to EN 61643-11.

		SRG T3 30	SRG T3 75	SRG T3 150	SRG T3 275
Electrical Features					
Nominal AC Voltage (50/60Hz)	Un	24 V	60 V	120 V	230 V
Max. Continuous Operating Voltage (L-N)	Uc	30 V	75 V	150 V	275 V
Max. Continuous Operating DC Voltage	Uc	38 V	100 V	--	--
Nominal discharge current (8/20µs)	In	10 kA			
Kombine Darbe	Uoc	10 kV			
Voltage protection level	Up	≤0,7 kV	≤0,8 kV	≤0,9 kV	≤1,3 kV
Response time	tA	≤25ns			
Mechanical Features					
Operating temperature range	Ta	-40 C° to +80 C°			
Humidity	RH	5%...%90			
Tightening Torque	Mmax	4,5 Nm			
Cable Cross-sectional area (max.)		35 mm ² Solid / Stranded / 25 mm ² Flexible			
For mounting on		35 mm DIN Rail EN 60715			
Casing Material		Thermoplastic, UL 94 V-0			
Degree of protection		IP20			
Specific Features					
Modular		HAYIR			
Fault Indicators		Green for ok / Red for fault			
Remote Fault Signaling		HAYIR			
Thermal Protection		YES			
Warranty		5 YEARS			



CIRCUIT DIAGRAM

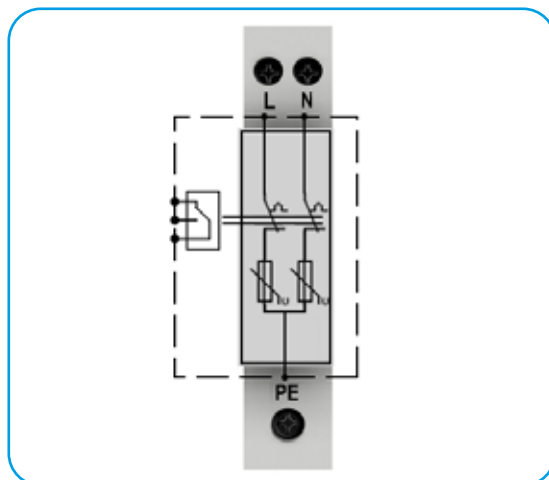

DIMENSIONS

Product Weight:	93 gr
Packaged Weight:	100 gr
Package Dimensions (ExBxY)	75x20x95 mm.

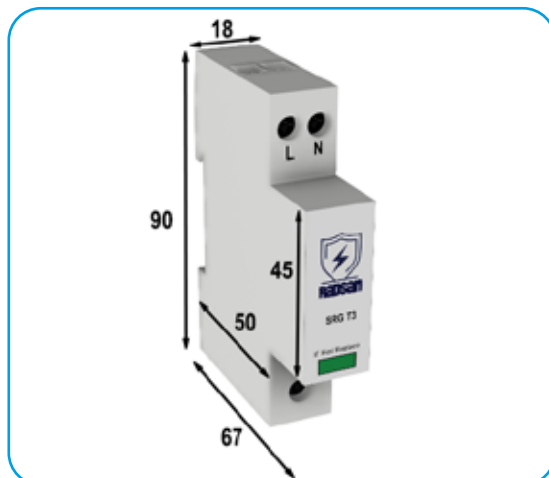

CONNECTION DIAGRAM

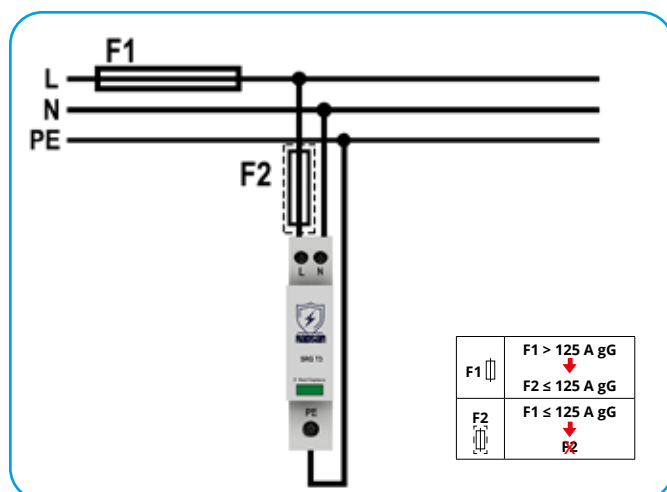



- Developed for DC Power systems.
- High level protection is provided by hybrid technology in which varistors and GDT are used together.
- Thanks to its compact design, SPD can be used easily even in the narrowest panels.
- Low maintenance cost thanks to modular design.
- Fault status can be monitored with the indicators on the SPD.
- With the dry contact output, the fault status can be monitored remotely.

A.G. according to EN 61643-11 standard Surge arrester class is DC.

SRG-20DP/24V RS

Electrical Features		
Nominal DC Gerilimi	Un	24 V DC
Highest Continuous Operating DC Voltage	Uc	36 V DC
Nominal discharge current (8/20µs)	In	20 kA
Max. discharge current (8/20µs)	Imax	40 kA
Voltage protection level (L-N)	Up	300 V
Combined Blow	Uoc	10 kV
Leakage Current	Ipe	≤0.1mA
Response time	tA	≤25ns
Mechanical Features		
Operating temperature range	Ta	-40 C° to +80 C°
Conductor Cross Section		2.5 - 16 mm ²
For mounting on		35 mm DIN Rail
Casing Material		Thermoplastic, UL 94 V-0
Degree of protection		IP20
Specific Features		
Modular		YES
Fault Indicators		Green for ok / Red for fault
Remote Fault Signaling		YES
Thermal Protection		YES
Warranty		2 YEARS



CIRCUIT DIAGRAM

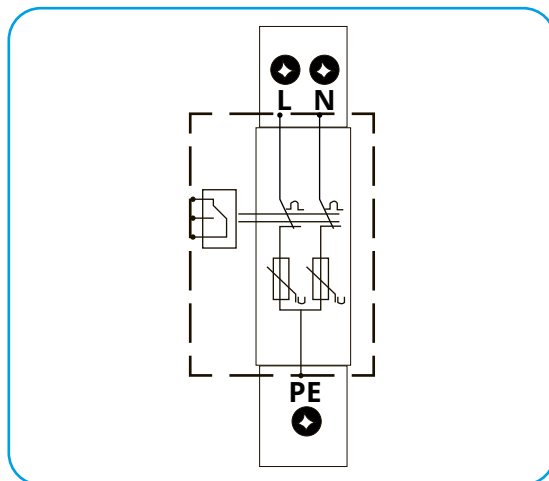

DIMENSIONS

Product Weight:	120 gr
Packaged Weight:	130 gr
Package Dimensions (ExBxY)	75x20x95

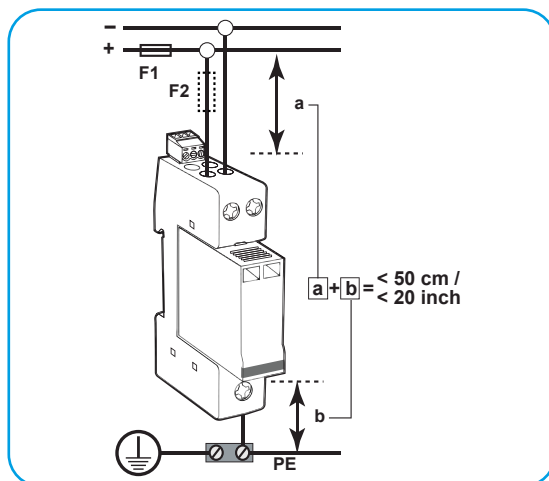

CONNECTION DIAGRAM

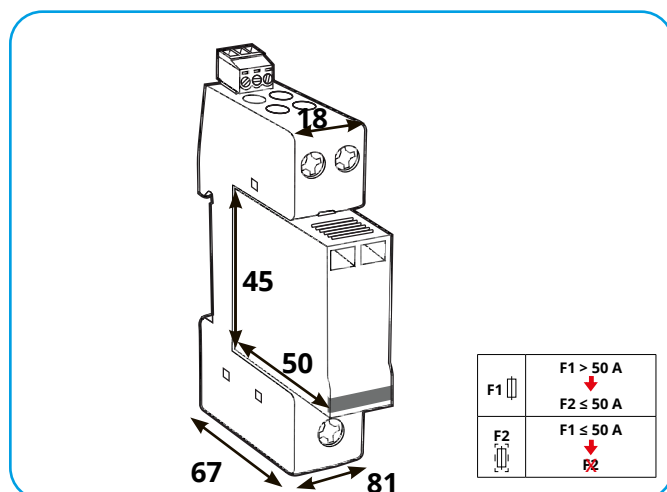



- Developed for DC Power systems.
- High level protection is provided by hybrid technology in which varistors and GDT are used together.
- Thanks to its compact design, SPD can be used easily even in the narrowest panels.
- Low maintenance cost thanks to modular design.
- Fault status can be monitored with the indicators on the SPD.
- With the dry contact output, the fault status can be monitored remotely.

A.G. according to EN 61643-11 standard Surge arrester class is DC.

SRG-40DP/75V RS

Electrical Features		
Nominal DC Gerilimi	Un	75 V DC
Highest Continuous Operating DC Voltage	Uc	100 V DC
Nominal discharge current (8/20µs)	In	20 kA
Max. discharge current (8/20µs)	Imax	40 kA
Voltage protection level (L-N)	Up	≤600V
Combined Blow	Uoc	10 kV
Leakage Current	Ipe	≤0.1mA
Front Fuse (Maximum)		125 gG
Response time	tA	≤25ns
Mechanical Features		
Operating temperature range	Ta	-40 C° to +80 C°
Conductor Cross Section		2.5 - 16 mm ²
For mounting on		35 mm DIN Rail
Casing Material		Thermoplastic, UL 94 V-0
Degree of protection		IP20
Specific Features		
Modular		YES
Fault Indicators		Green for ok / Red for fault
Remote Fault Signaling		YES
Thermal Protection		YES
Warranty		2 YEARS



CIRCUIT DIAGRAM

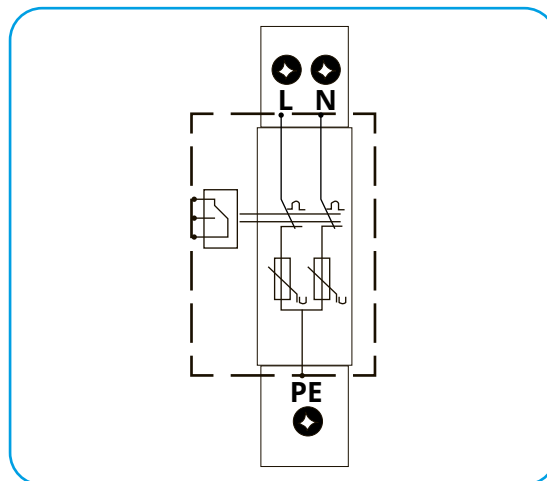

DIMENSIONS

Product Weight:	120 gr
Packaged Weight:	130 gr
Package Dimensions (ExBxY)	75x20x95

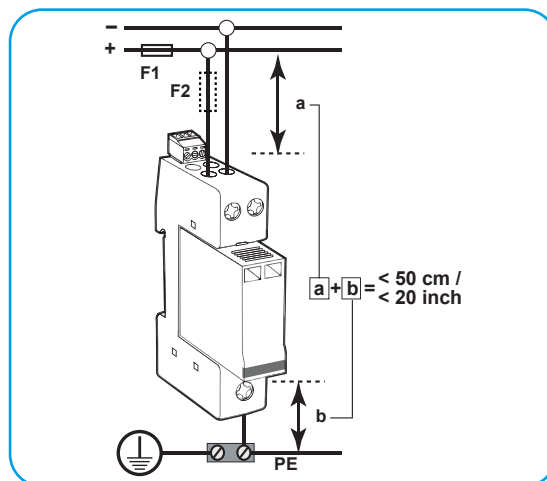

CONNECTION DIAGRAM

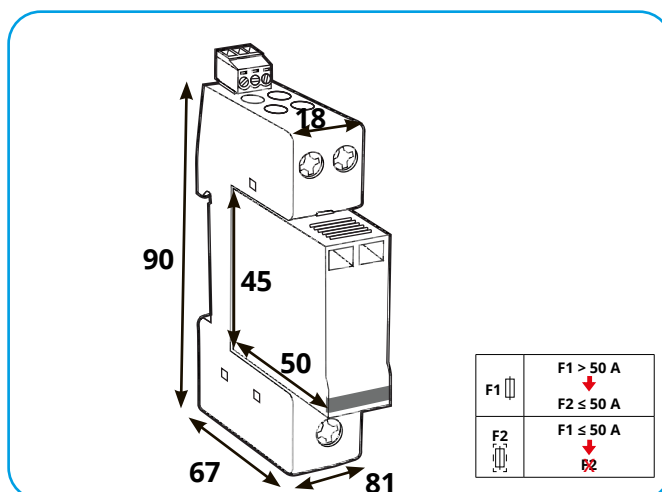



- Developed for DC Power systems.
- High level protection is provided by hybrid technology in which varistors and GDT are used together.
- Thanks to its compact design, SPD can be used easily even in the narrowest panels.
- Low maintenance cost thanks to modular design.
- Fault status can be monitored with the indicators on the SPD.
- With the dry contact output, the fault status can be monitored remotely.

A.G. according to EN 61643-11 standard Surge arrester class is DC.

SRG-40DP/75V RS

Electrical Features		
Nominal DC Gerilimi	Un	110 V DC
Highest Continuous Operating DC Voltage	Uc	150 V DC
Nominal discharge current (8/20µs)	In	20 kA
Max. discharge current (8/20µs)	Imax	40 kA
Voltage protection level (L-N)	Up	≤600V
Combined Blow	Uoc	10 kV
Leakage Current	Ipe	≤0.1mA
Front Fuse (Maximum)		125 gG
Response time	tA	≤25ns
Mechanical Features		
Operating temperature range	Ta	-40 C° to +80 C°
Conductor Cross Section		2.5 - 16 mm ²
For mounting on		35 mm DIN Rail
Casing Material		Thermoplastic, UL 94 V-0
Degree of protection		IP20
Specific Features		
Modular		YES
Fault Indicators		Green for ok / Red for fault
Remote Fault Signaling		YES
Thermal Protection		YES
Warranty		2 YEARS



CIRCUIT DIAGRAM

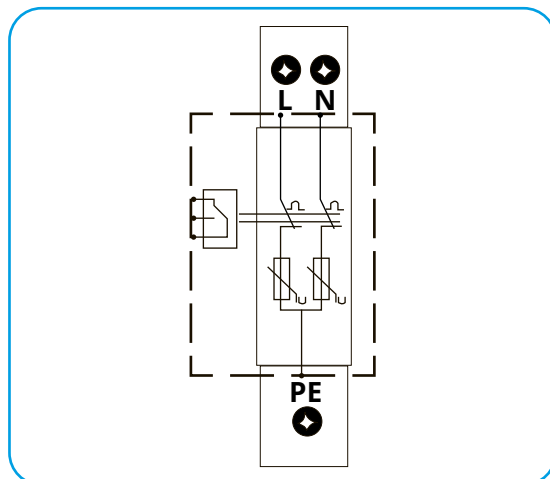

DIMENSIONS

Product Weight:	120 gr
Packaged Weight:	130 gr
Package Dimensions (ExBxY)	75x20x95

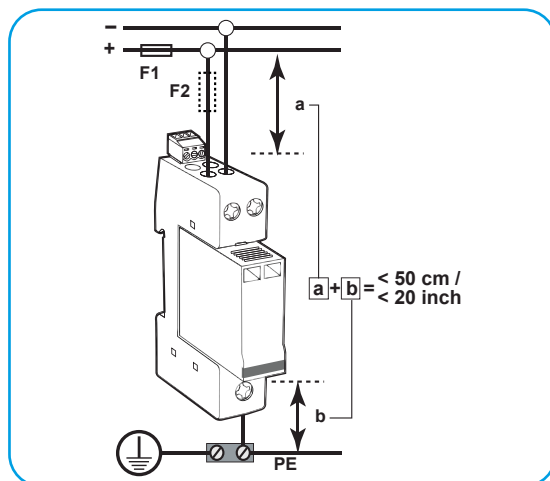

CONNECTION DIAGRAM

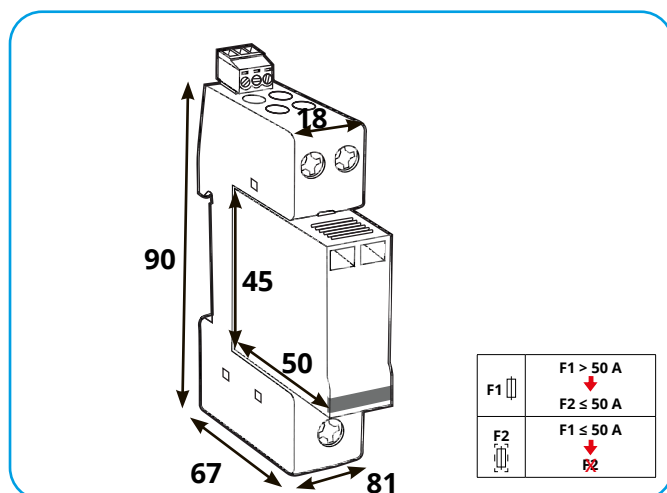



- High level protection is provided by hybrid technology in which varistors and GDT are used together.
- Thanks to its compact design, SPD can be used easily even in the narrowest panels
- Low maintenance cost thanks to modular design.
- Fault status can be monitored with the indicators on the SPD.
- With the dry contact output, the fault status can be monitored remotely.
- Designed and manufactured in Turkiye.
- 5 years of warranty

SRG PV T1 1200

Electrical Features

Nominal DC Voltage	Un	1000 V
Highest Continuous Operating DC Voltage	U _{CPV}	1200 V
Impulse Current per Pole	I _{imp}	5 kA
Nominal discharge current (8/20μs)	I _n	20 kA
Max. discharge current (8/20μs)	I _{max}	50 kA
Voltage protection level	Up	≤4 kV
Residual Current	IPE	<0.1mA
Following Current	I _{fi}	None
Max. backup fuse		125 A gL
Response time	t _A	≤25ns

Mechanical Features

Operating temperature range	T _a	-40 C° to +80 C°
Humidity	RH	5%...%90
Tightening Torque	M _{max}	4,5 Nm
Cable Cross-sectional area (max.)		35 mm ² Solid / Stranded / 25 mm ² Flexible
For mounting on		35 mm DIN Rail EN 60715
Casing Material		Thermoplastic, UL 94 V-0
Degree of protection		IP20

Specific Features

Modular		YES
Fault Indicators		Green for ok / Red for fault
Remote Fault Signaling		YES
Thermal Protection		YES
Warranty		5 YEARS



CIRCUIT DIAGRAM

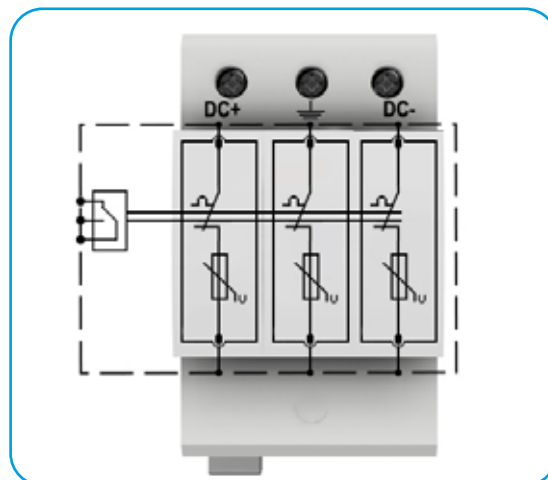

DIMENSIONS

Product Weight:	350 gr
Packaged Weight:	370 gr
Package Dimensions (ExBxY)	60x100x85 mm

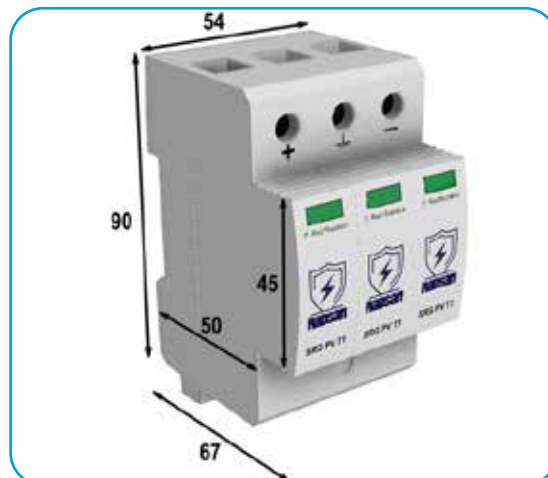

CONNECTION DIAGRAM

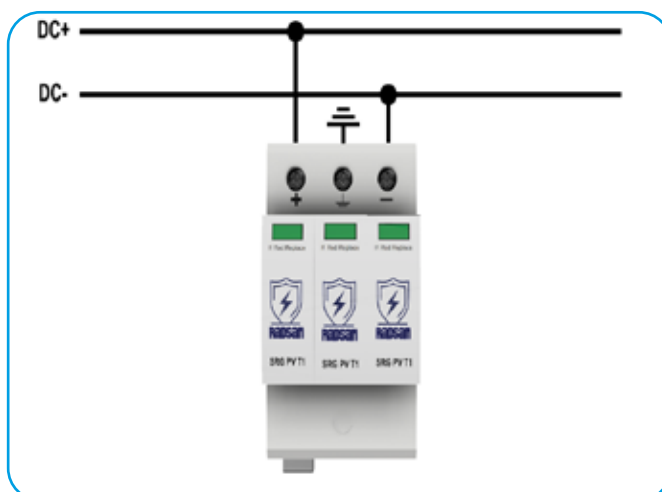



- High level protection is provided by hybrid technology in which varistors and GDT are used together.
- Thanks to its compact design, SPD can be used easily even in the narrowest panels
- Low maintenance cost thanks to modular design.
- Fault status can be monitored with the indicators on the SPD.
- With the dry contact output, the fault status can be monitored remotely.
- Designed and manufactured in Turkiye.
- 5 years of warranty

SRG PV T2 1000

Electrical Features

Highest Continuous Operating DC Voltage	U_{CPV}	1000 V
Nominal discharge current (8/20 μ s)	I_n	20 kA
Max. discharge current (8/20 μ s)	I_{max}	40 kA
Voltage protection level	U_p	≤ 4 kV
Short Circuit Resistance	I_{scpv}	1000 A
Max. backup fuse		125 A gL
Response time	t_A	≤ 25 ns

Mechanical Features

Operating temperature range	T_a	-40 C° to +80 C°
Humidity	RH	5%...%90
Tightening Torque	M_{max}	4,5 Nm
Cable Cross-sectional area (max.)		35 mm ² Solid / Stranded / 25 mm ² Flexible
For mounting on		35 mm DIN Rail EN 60715
Casing Material		Thermoplastic, UL 94 V-0
Degree of protection		IP20

Specific Features

Modular		YES
Fault Indicators		Green for ok / Red for fault
Remote Fault Signaling		YES
Thermal Protection		YES
Warranty		5 YEARS



CIRCUIT DIAGRAM

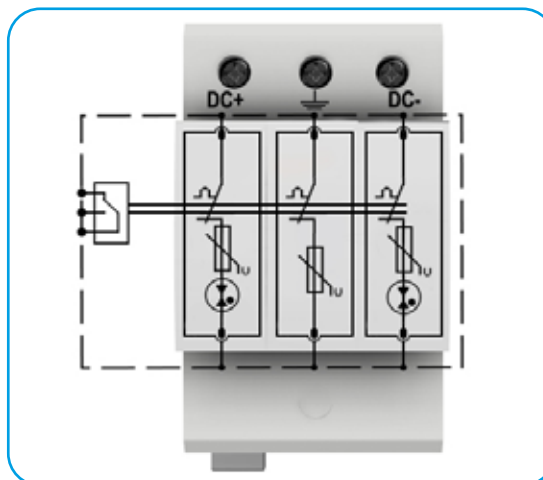

DIMENSIONS

Product Weight:	300 gr
Packaged Weight:	320 gr
Package Dimensions (ExBxY)	60x100x85 mm



CONNECTION DIAGRAM

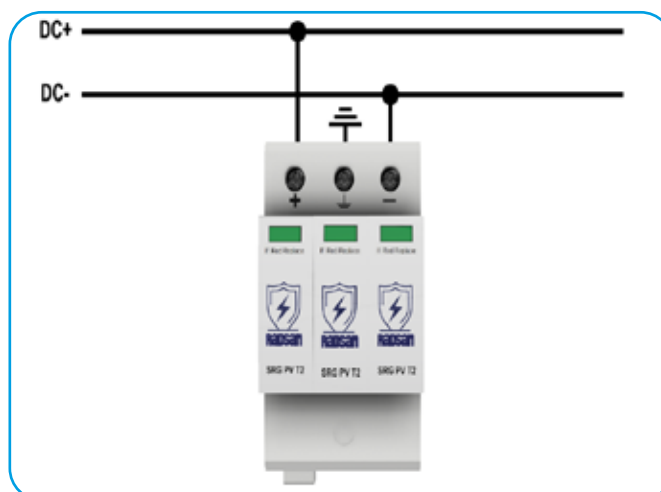



- High level protection is provided by hybrid technology in which varistors and GDT are used together.
- Thanks to its compact design, SPD can be used easily even in the narrowest panels
- Low maintenance cost thanks to modular design.
- Fault status can be monitored with the indicators on the SPD.
- With the dry contact output, the fault status can be monitored remotely.
- Designed and manufactured in Turkiye.
- 5 years of warranty

A.G. according to EN 61643-11 standard Surge arrester class is PV.

SRG T1+2 600 RS

Electrical Features

Maximum Continuous Operation A.C. Income	Uc	600V
Lightning impulse current (10/350µs)	Iimp	12.5kA
Nominal discharge current (8/20µs)	In	20kA
Max. discharge current (8/20µs)	I _{max}	100kA
Voltage protection level	Up	≤3.0 kV
Specific Energy	W/R	39kJ/Ω
Charge	Q	6.25As
Short Circuit Withstand Capacity	I _{SSCCR}	25kA
Maximum Front Fuse		125A gG
Leakage Current	I _{PE}	<1mA
Response time	t _A	≤25ns

Mechanical Features

Operating temperature range	Ta	-40 C° to +80 C°
Humidity	RH	5%....%90
Tightening Torque	M _{max}	4,5 Nm
Cable Cross-sectional area (max.)		35 mm ² Solid / Stranded / 25 mm ² Flexible
For mounting on		35 mm DIN Rail EN 60715
Casing Material		Thermoplastic, UL 94 V-0
Degree of protection		IP20

Specific Features

Modular		YES
Fault Indicators		Green for ok / Red for fault
Remote Fault Signaling		YES
Thermal Protection		YES
Warranty		5 YEARS



CIRCUIT DIAGRAM

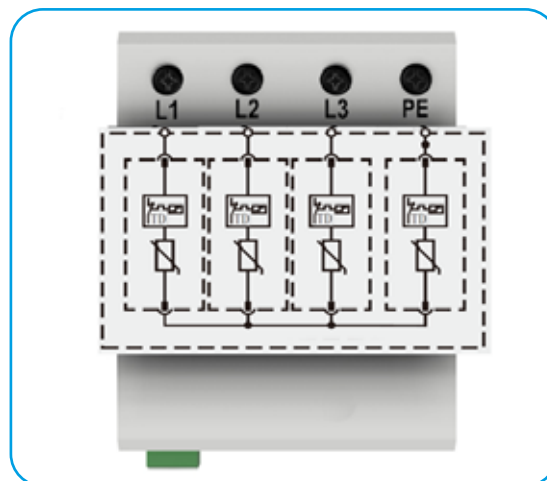

DIMENSIONS

Product Weight:	355 gr
Packaged Weight:	385 gr
Package Dimensions (ExBxY)	75x100x77 mm.

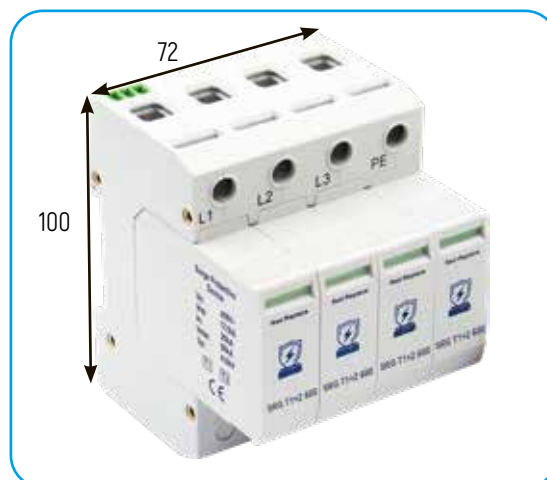

CONNECTION DIAGRAM

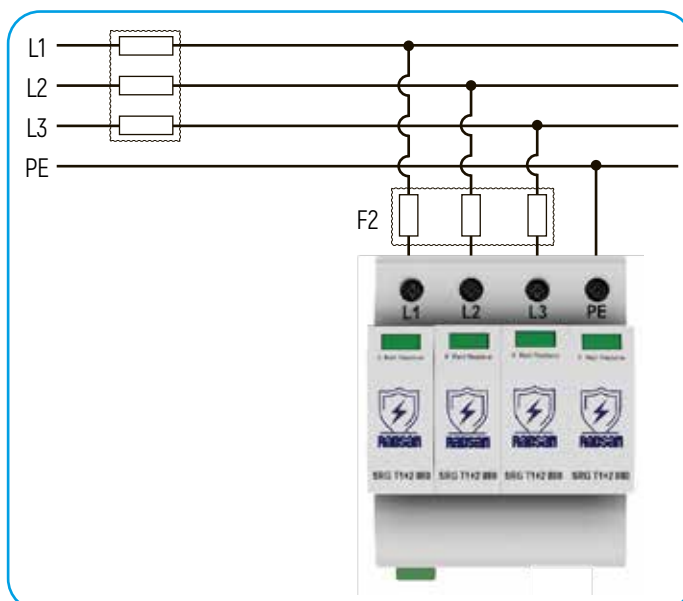

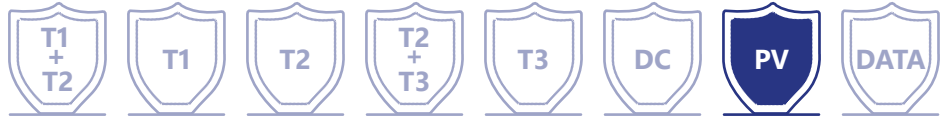

- High level protection is provided by hybrid technology in which varistors and GDT are used together.
- Thanks to its compact design, SPD can be used easily even in the narrowest panels
- Low maintenance cost thanks to modular design.
- Fault status can be monitored with the indicators on the SPD.
- With the dry contact output, the fault status can be monitored remotely.
- Designed and manufactured in Turkiye.
- 5 years of warranty

A.G. according to EN 61643-11 standard Surge arrester class is PV.

SRG T1+2 1000 RS

Electrical Features		
Maximum Continuous Operation A.C. Income	Uc	1000V
Lightning impulse current (10/350µs)	Iimp	12.5kA
Nominal discharge current (8/20µs)	In	20kA
Max. discharge current (8/20µs)	I _{max}	50kA
Voltage protection level	Up	≤4.0 kV
Specific Energy	W/R	39kJ/Ω
Charge	Q	6.25As
Short Circuit Withstand Capacity	I _{SSCCR}	25kA
Maximum Front Fuse		125A gG
Leakage Current	I _{PE}	<1mA
Response time	t _A	≤25ns
Mechanical Features		
Operating temperature range	T _a	-40 C° to +80 C°
Humidity	RH	5%...%90
Tightening Torque	M _{max}	4,5 Nm
Cable Cross-sectional area (max.)		35 mm ² Solid / Stranded / 25 mm ² Flexible
For mounting on		35 mm DIN Rail EN 60715
Casing Material		Thermoplastic, UL 94 V-0
Degree of protection		IP20
Specific Features		
Modular		YES
Fault Indicators		Green for ok / Red for fault
Remote Fault Signaling		YES
Thermal Protection		YES
Warranty		5 YEARS



CIRCUIT DIAGRAM

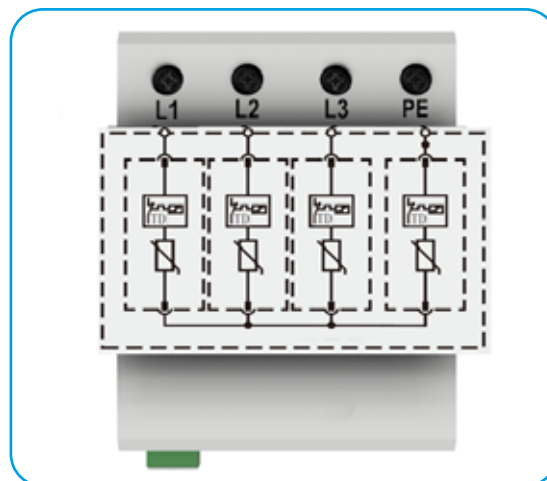

DIMENSIONS

Product Weight:	355 gr
Packaged Weight:	385 gr
Package Dimensions (ExBxY)	75x100x77 mm.

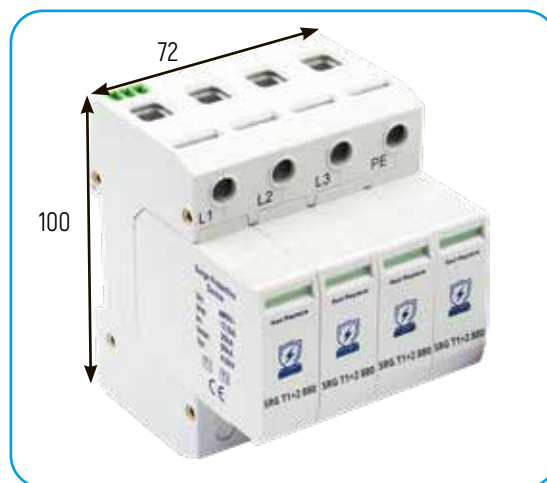

CONNECTION DIAGRAM

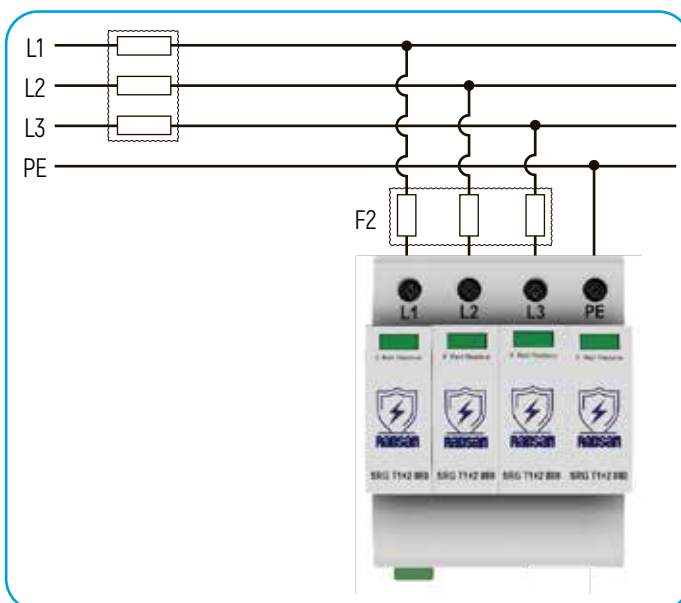



Superior protection is provided with GDT technology.

Thanks to its compact design, SPD can be used easily even in the narrowest panels.

Low maintenance cost thanks to modular design.

Designed and manufactured in Turkiye.

5 years of warranty

It is classified according to the EN 61643-21 standard.

		SRG PI 6	SRG PI 12	SRG PI 24	SRG PI 48
Electrical Features					
Nominal AC Voltage (50/60Hz)	Un	6 V	12 V	24 V	48 V
Max. Continuous Operating Voltage (L-N)	Uc	5 V	11 V	20 V	40 V
Maximum Continuous Operating DC Voltage	Uc	8 V	15 V	30 V	56 V
Nominal Current	I_L	0,4 A			
Nominal discharge current (8/20 μ s)	I_n	5 kA			
Voltage protection level (L-L)	Up	≤ 30 V	≤ 40 V	≤ 60 V	≤ 130 V
Voltage protection level (L-PG)	Up	≤ 600 V	≤ 600 V	≤ 600 V	≤ 600 V
Response time (L-L)	tA	≤ 1 ns			
Response time (L-PG)	tA	≤ 100 ns			
Bandwidth	Up	10 Mbps			
Insertion Loss	tA	$\leq 0,3$ dB			
Mechanical Features					
Operating temperature range	Ta	-40 C° to +80 C°			
Humidity	RH	5%...%90			
Tightening Torque	Mmax	4,5 Nm			
Cable Cross-sectional area (max.)		35 mm ² Solid / Stranded / 25 mm ² Flexible			
For mounting on		35 mm DIN Rail EN 60715			
Casing Material		Thermoplastic, UL 94 V-0			
Degree of protection		IP40			
Modular		YES			

DIMENSIONS

Product Weight:	65 gr
Packaged Weight:	75 gr
Package Dimensions (ExBxY)	20x70x95 mm.

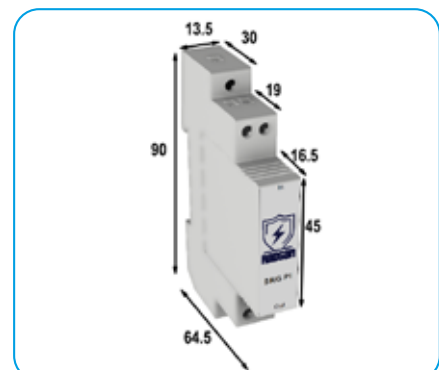



Superior protection is provided with GDT technology.

Thanks to its compact design, SPD can be used easily even in the narrowest panels.

Designed and manufactured in Turkiye.

5 years of warranty

Classified according to EN 61643-21 standard.

SRG-POE

Electrical Features

Nominal Gerilim	Un	48 V
Maximum Continuous Operating DC Voltage	Uc	56 V
Nominal Current	I _L	1 A
C2 Nominal discharge current (8/20µs) line-PG	I _n	10 kA
Voltage protection level (L-L)	Up	≤30 V
Voltage protection level (L-PG)	Up	≤600 V
Response time (L-L)	tA	≤1 ns
Response time (L-PG)	tA	≤100 ns
Bandwidth		1 Gbps
Insertion Loss		≤0,3 dB
Entry - Exit		RJ-45, PoE

Mechanical Features

Operating temperature range	Ta	-40 C° to +80 C°
Humidity	RH	5%...%90
Casing Material		Aluminium Alloy
Degree of protection		IP40

DIMENSIONS

Product Weight:	100 gr
Packaged Weight:	111.5 gr
Package Dimensions (ExBxY)	53x33x53mm





Superior protection is provided with GDT technology.
Thanks to its compact design, SPD can be used easily even in the narrowest panels. Designed and manufactured in Türkiye.
5 years of warranty

EN 61643-21 standardına göre sınıflandırılmıştır.

SRG-RJ45

Electrical Features

Nominal Voltage	Un	6 V
Maximum Continuous Operating DC Voltage	Uc	6 V
Max. Continuous Operating Voltage (L-N)	Uc	4 V
Nominal Current	IL	0,5 A
C2 Nominal discharge current (8/20µs) line-PG	In	5 kA
Voltage protection level (L-L)	Up	≤30 V
Voltage protection level (L-PG)	Up	≤500 V
Response time (L-L)	tA	≤1 ns
Response time (L-PG)	tA	≤100 ns
Bandwidth		300 Mbps
Insertion Loss		≤0,3 dB
Entry - Exit		RJ-45, 8 line

Mechanical Features

Operating temperature range	Ta	-40 C° to +80 C°
Humidity	RH	5%...%90
Casing Material		Aluminium Alloy
Degree of protection		IP40

DIMENSIONS

Product Weight:	76 gr
Packaged Weight:	88 gr
Package Dimensions (Ex-BxY)	35x105x60 mm.





GDT teknolojisi ile üstün koruma sağlanır.

Thanks to its compact design, SPD can be used easily even in the narrowest panels. Designed and manufactured in Türkiye.

5 years of warranty

EN 61643-21 standardına göre sınıflandırılmıştır.

		SRG BNC	SRG BNC.H
Electrical Features			
Nominal Voltage	Un	5 V	-
Maximum Continuous Operating DC Voltage	Uc	6 V	180 V
Max. Continuous Operating Voltage (L-N)	Uc	4 V	130 V
Nominal Current	IL	0,5 A	20 A
C2 Nominal discharge current (8/20µs) line-shield	In	5 kA	-
C2 Nominal discharge current (8/20µs) shield-PG	In	10 kA	-
C2 Nominal discharge current (8/20µs) line-shield/PG		-	10 kA
Voltage protection level (L-shield)	Up	≤30 V	-
Voltage protection level (shield-PG)	Up	≤500 V	-
Voltage protection level (line-shield/PG)		-	≤800 V
Response time (L-shield))	tA	≤1 ns	-
Response time (shield-PG)	tA	≤100 ns	-
Response time (line-shield/PG)	tA	-	≤100 ns
Bandwidth			10 Mbps
Insertion Loss			≤0,3 dB
Empedans			50 Ω
Entry - Exit			BNC
Mechanical Features			
Operating temperature range	Ta	-40 C° to +80 C°	
Humidity	RH	5%...%90	
Casing Material		Aluminium Alloy	
Degree of protection		IP40	

DIMENSIONS

Product Weight:	66 gr
Packaged Weight:	80 gr
Package Dimensions (ExBxY)	40x30x90 mm.





High level protection is provided by hybrid technology in which varistors and GDT are used together.

Thanks to its compact design, SPD can be used easily even in the narrowest panels.

Designed and manufactured in Türkiye.

5 years of warranty

It is classified according to the EN 61643-21 standard.

SRG LSA

Electrical Features

Nominal Voltage	Un	180 V
Maximum Continuous Operating DC Voltage	Uc	180 V
Max. Continuous Operating Voltage (L-N)	Uc	127 V
Nominal Current	IL	0,4 A
C2 Nominal discharge current (8/20µs) line-shield	In	5 kA
C2 Nominal discharge current (8/20µs) shield-PG	In	10 kA
C2 Nominal discharge current (8/20µs) line-shield/PG		2,5 kA
Voltage protection level (L-shield)	Up	5 kA
Voltage protection level (shield-PG)	Up	≤500 V
Voltage protection level (line-shield/PG)		≤500 V

Mechanical Features

Operating temperature range	Ta	-40 C° to +80 C°
Humidity	RH	5%...%90
Casing Material		Polyamide
Degree of protection		IP40

DIMENSIONS

Product Weight:	65 gr
Packaged Weight:	75 gr
Package Dimensions (ExBxY)	25x120x40 mm.

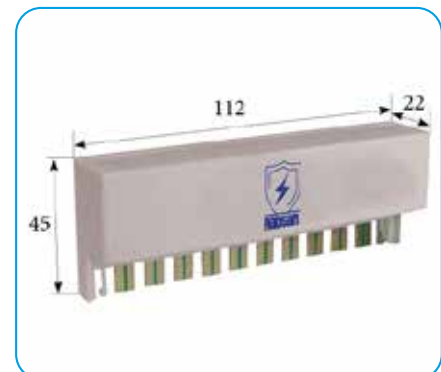



High level protection is provided by hybrid technology in which varistors and GDT are used together.

Thanks to its compact design, SPD can be used easily even in the narrowest panels. Designed and manufactured in Türkiye.

5 years of warranty

It is classified according to the EN 61643-21 standard.

SRG SUBD 9 SRG SUBD 15 SRG SUBD 25

Electrical Features				
Nominal Voltage	Un	12 V	12 V	12 V
Maximum Continuous Operating DC Voltage	Uc	15 V	15 V	15 V
C2 Nominal discharge current (8/20µs) line-shield	In	5 kA	5 kA	5 kA
C2 Nominal discharge current (8/20µs) shield-PG	In	10 kA	10 kA	10 kA
Voltage protection level (L-shield)	Up	≤40 V	≤40 V	≤40 V
Voltage protection level (shield-PG)	Up	≤500 V	≤500 V	≤500 V
Response time (L-shield))	tA	≤1 ns	≤1 ns	≤1 ns
Response time (shield-PG)	tA	≤100 ns	≤100 ns	≤100 ns
Bandwidth		10 Mbps	10 Mbps	10 Mbps
Insertion Loss		≤0,3 dB	≤0,3 dB	≤0,3 dB
Giriş-Çıkış		SUB-D 9 plug/socket	SUB-D 15 plug/socket	SUB-D 25 plug/socket
Pin		line 3/8, SG:5, PG:1	line 2/9/4/11, SG:8, PG:1	line: 2/3/4/5/6/8/20, SG:7, PG:1

Mechanical Features		
Operating temperature range	Ta	-40 C° to +80 C°
Humidity	RH	5%...%90
Casing Material		Aluminium Alloy
Degree of protection		IP40

DIMENSIONS

Product Weight:	32 gr
Packaged Weight:	40 gr
Package Dimensions (ExBxY)	35x60x20 mm

