

Our company, which has been operating in the grounding and lightning protection sector since 1953, is the market leader thanks to its many years of experience, design and R&D expertise, strong production infrastructure, domestic/international application capabilities, customer satisfaction-oriented sales activities, and after-sales support capabilities.

Innovation and Quality

- ✓ 1953 Founded
- ✓ 1962 FIRST Production Facility
- ✓ 1974 FIRST Radioactive Lightning Rod Production in Turkey
- ✓ 1987 Cable Boot Production
- ✓ 1998 Commissioning of the Integrated Production Facility [26,000 m² area with 7,200 m² of covered space]
- ✓ 2002 First Active Lightning Rod Production in Turkey
- ✓ 2008 Implementation of ERP System
- ✓ 2011 Integrated Quality Management System (ISO 9001, ISO 14001, ISO 18001)
- ✓ 2013 First member from Turkey accepted into ILPA (International Lightning Protection Association)
- ✓ 2014 First and only Lightning Detection and Warning Network established in Turkey
- ✓ 2015 Commissioning of the Grounding Strip Production Line
- ✓ 2015 Opening of the Marmara Regional Directorate
- ✓ 2017 Thermoweld Production
- ✓ 2018 Opening of the Aegean Regional Directorate
- ✓ 2020 FIRST and ONLY A.G. Surge Protector Production in Turkey
- ✓ 2021 Opening of the Gaziantep Regional Directorate

HASANOĞLAN FACTORY



İSTANBUL BRANCH



İZMİR BRANCH



GAZİANTEP BRANCH



RADSAN CENTER

CONTENTS

LIGHTNING PROTECTION

Need of Protection and Radsan Protection Concept	4 - 7
Aircraft Warning Lamps	8 - 10
Lightning and Lightning Protection Basics	11
Ese Lightning Arresters	12 - 15
Testers and Counters	16
Smart Coding	17
Application Examples	18 - 22
ESE Lightning Arrester Installation Equipments	23 - 25
ESE Lightning Arrester Installation Equipments	26 - 34
Mesh Method and Installation Equipments	35 - 47
Stretch Wire Method	48 - 51
Down Conductors	52
Down Conductor Installation Equipments	53 - 80

A.G. SURGE ARRESTER SERIES

A.G. Parafudr	81 - 86
Technical Principles	87 - 102
T1+2 Class	103 - 127
T1 Class	128 - 139
T2 Class	140 - 147
T2+3 Class	148 - 153
T3 Class	154 - 155
DC Class	156 - 161
PV Class	162 - 169
Data SPDs	170 - 175

EARTHING

Smart Coding	179
Conductor Specs	180
Conductors Hot Dip Galvanized Steel Conductors Copper Conductors	181 - 188
Clemens	189 - 201
Electrodes Hot Dip Galvanized Steel Electrodes Copper Electrodes Earthing Plates	202 - 211
Earthing Rod Connectors	212 - 211
Rem	212 - 214
Earthing Points	215 - 217
Bars	218 - 222
Earthing Drums	223
Static Earthing Pit	224
Earthing Pit	225
Earthing Measurement Devices	226
CADWELD	227 - 236

CABLE LUGS

Secure Connection - Secure Service	239
SKP Cable Lugs DIN 46235 Series Standard Series Standard Long Series Economical Series Aluminum Series Bimetal Series	240 - 246
Butt Connectors DIN Series TSE Series Ekonomik Series	247
Compression Tips	248

LIGHTNING PROTECTION



LIGHTNING

HOW IS LIGHTNING FORMED?



Under normal conditions, there is a charge balance between the earth and the atmosphere. The formation of storm clouds disrupts this balance, causing polarization. Lightning and thunder occur when the disrupted charge balance is restored.

Ninety percent of lightning strikes are negative lightning strikes from the cloud to the ground. In this type of lightning, the lower regions of the cloud have a negative charge. This charge charges the earth and objects on it with a positive charge. The positive charge on the earth is more concentrated in metal objects, pointed objects, and well-grounded objects.

The required electric field strength for lightning to form is 0.5-10 kV/cm. When the electric field increases sufficiently, a leader current begins to flow from the cloud to the ground. This current and charge cause a corona effect on objects on the ground. One of the upward currents created by these objects catches the leader current and carries it to the ground.

CHARACTERISTICS OF LIGHTNING

- The formation of the leading edge occurs step by step. Lightning travels 10-100 meters with each step.
- The waiting time between steps is 30-90 microseconds.
- The average speed of lightning is 50,000 km/s.
- The amount of electrical charge discharged in a lightning event is 10-20 A.s (1 A.s = 1 coulomb).
- Lightning protection standards assume that the peak value (100 kA) of the lightning reaches 90% within 10 microseconds, and the decay time is 350 microseconds.
- Current/time graph of lightning obtained experimentally in the laboratory:

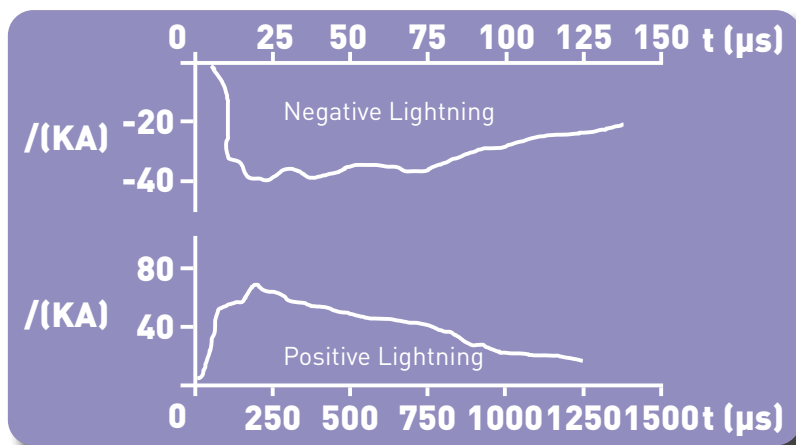

NECESSITY OF PROTECTION

Lightning is a natural disaster like earthquakes, tornadoes, and floods. Unlike other disasters, it does not cause damage to large areas, but it causes significant problems where it strikes. Unlike other disasters, it is not rare; millions of lightning strikes occur every day. Lightning strikes cause damage to people, animals, buildings, and devices. This damage is classified into four different categories:

- Loss of life and injury: directly threatens people and animals.
- Material losses: fires in buildings and malfunctions in electrical devices we use.
- Service losses: electricity, water, and gas distribution networks, services provided over the internet.
- Cultural losses: Damage to historical artifacts

To protect yourself from the wrath of lightning, it is essential to understand the disaster and act consciously. People should protect themselves in open areas and take necessary precautions for their structures.

RISK ANALYSIS MANAGEMENT and PROTECTION

In order to provide conscious protection, it is first necessary to thoroughly analyze the structure to be protected, determine the measures to be taken against the risk, and take the appropriate measures.

The analysis of the structure and related engineering work must be carried out in accordance with TS EN 62305. The lightning protection level "YKS" is calculated using the calculation method given in this standard and the NFC 17-102 standard. YKS is defined by levels ranging from one to four. Level 1 represents the highest risk level, while Level 4 indicates the lowest risk level. The appropriate protection system is determined based on the structure's YKS level.

To implement the calculated and designed lightning protection system, high-quality products and skilled labor are required. Products compliant with the TS EN 62561 standard are considered high-quality products. Unfortunately, there is no standard for skilled labor in our country. Companies' SMM certificates, ISO management systems, engineering staff, and expertise should serve as evaluation criteria.

RADSAN PROTECTION CONCEPT

The most advanced technologies and safest products should be used for true security.

With the experience we have gained since 1953, we believe that there are four basic rules for true protection.



1. EARLY WARNING:

The best way to protect yourself from natural disasters is to receive advance warning. Thanks to the first and only lightning warning system in Turkey, which we have established, people can be warned one hour in advance, minimizing loss of life and property damage.



2. CATCH THE LIGHTNING:

An external lightning protection system is designed to attract lightning strikes. This allows lightning to be conducted to the ground via a controlled path.

Designing a correct, durable system prevents potential fires, loss of life, injury, and material losses.



3. GROUNDING:

Lightning, which is a very powerful electrical phenomenon, cannot be neutralized.

The only way to avoid damage is to ground it.

Therefore, GROUNDING is the basis of protection.



4. PROTECT ELECTRONIC SYSTEMS:

Lightning is a high-voltage event, and even if it is properly grounded, today's sensitive electronic systems can be damaged. Special protection methods should be applied for televisions, computers, smart buildings, advanced technology automation systems, and communication systems in homes.

LIGHTNING PROTECTION

CATCH THE LIGHTNING

GROUNDING

LIGHTNING ROD SYSTEM



CAGE SYSTEM

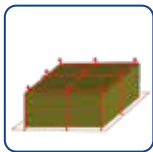

LIGHTNING PROTECTION AND EARTHING INSTALLATION PRODUCTS

A.G. PARAFUDR SİSTEMİ

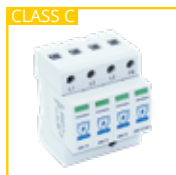

GROUNDING SYSTEM



AIRCRAFT WARNING LAMPS



RWL.01

SINGLE: Single aircraft warning in one lamp

2 in 1: Dual aircraft warning in one lamp

AIRCRAFT WARNING LIGHT

TEKLI

WORKING VOLTAGE	48-250 V AC / DC
	12-36 V AC / DC
	12/24/48 V DC
FLASH DURATION	1 Hz.
TEST RANGE	Max. 15 minute
ELECTRICAL POWER	Max. 4 watt
MODE	<ul style="list-style-type: none"> • DAYTIME (24 hours) CONTINUOUS LIGHT • DAYTIME CONTINUOUS FLASH (FLASHES) <ul style="list-style-type: none"> • CONTINUOUS LIGHT IN THE DARK • FLASH IN THE DARK (FLASHES ON AND OFF)
ALARM OUTPUT	Dry Contact
NC	No Power
UPPER PART	Clear Glass, Clear Plastic
LOWER PART	Aluminum, ABS Plastic
SIZE	Ø110 mm, H:220/160 mm
POLE DIAMETER	42 mm, 1 ^{1/4} "

LED FEATURES

LED NO	4 Power Led
POWER (WATT)	3 W
WAVELENGTH	620 - 630nm
LIGHTING	min. 50 lumen / LED
TERMS OF USE	50.000 clock

Please request a quote for different types.



UÇAK İKAZ LAMBALARI / AIRCRAFT WARNING LAMPS



İKİLİ UÇAK İKAZ LAMBASI

UÇAK İKAZ LAMBASI

2 in 1 İKİLİ UÇAK İKAZ LAMBASI

WORKING VOLTAGE	48-250 V AC / DC
	12-36 V AC / DC
	12/24/48 V DC
FLASH DURATION	1 Hz.
TEST RANGE	Max. 15 minute
ELECTRICAL POWER	Max. 4 watt
MODE	<ul style="list-style-type: none"> • DAYTIME (24 hours) CONTINUOUS LIGHT • DAYTIME CONTINUOUS FLASH (FLASHES) <ul style="list-style-type: none"> • CONTINUOUS LIGHT IN THE DARK • FLASH IN THE DARK (FLASHES ON AND OFF)
ALARM OUTPUT	Dry Contact
NC	LED Failure
UPPER PART	Güç Yok
LOWER PART	Şeffaf Cam, Şeffaf Plastik
SIZE	Aluminum, ABS Plastic
POLE DIAMETER	Ø110 mm, H:220/160 mm
POLE DIAMETER	42 mm, 1 ^{1/4} "

LED FEATURES

LED NO	4 Power Led
POWER (WATT)	3 W
WAVELENGTH	620 - 630nm
LIGHTING	min. 50 lumen / LED
TERMS OF USE	50.000 clock

Please request a quote for different types.



Solar Panel Power Supply / RSWL.01

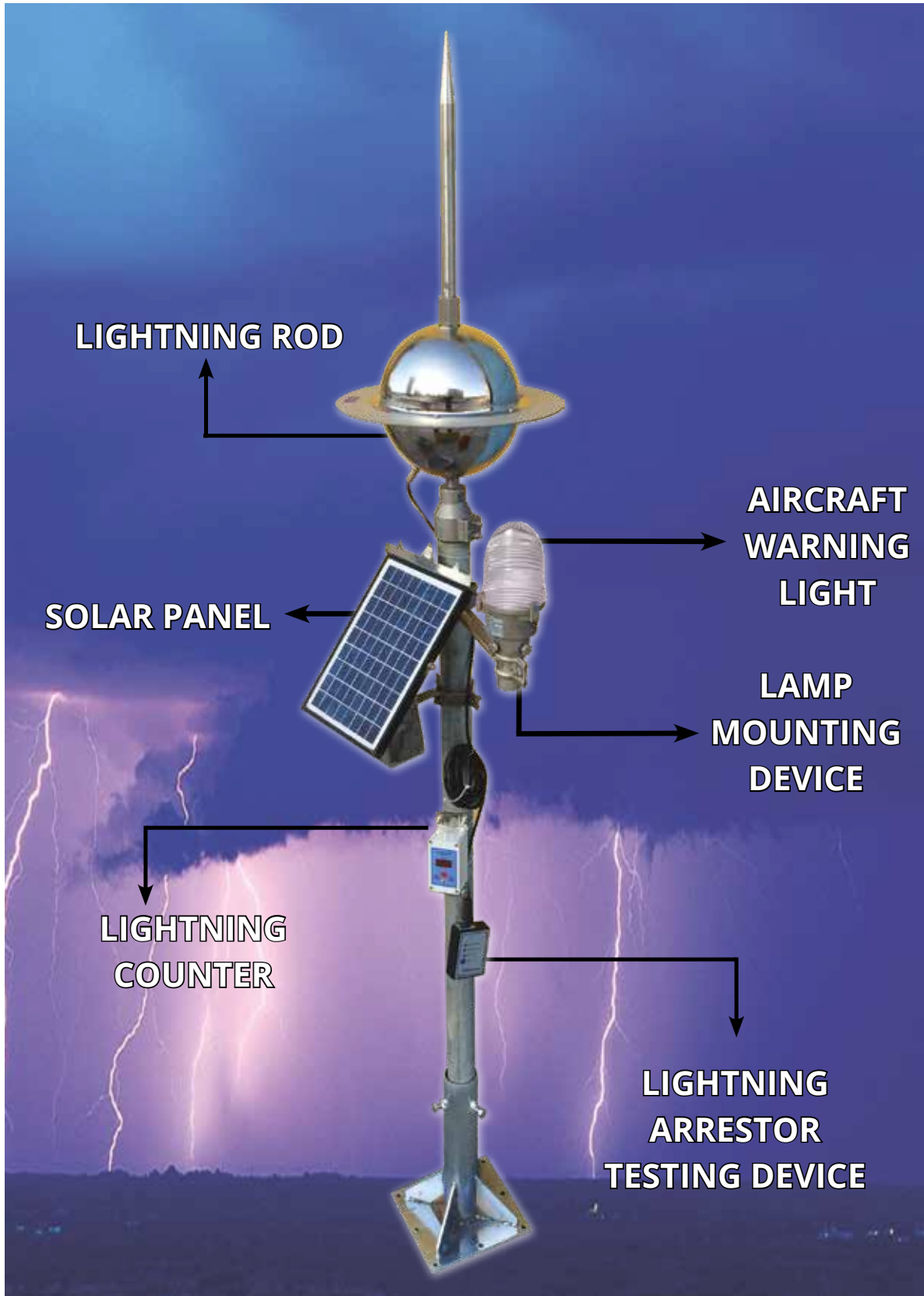

LIGHTNING PROTECTION

WHAT IS AN ACTIVE LIGHTNING ROD?

No technology has yet been developed that can prevent lightning from forming.

Active lightning rod technology has been developed to capture lightning approaching a structure and conduct it to the ground via a safe path.

Active lightning protection begins capturing lightning earlier than other objects within its protection radius, thereby capturing the lightning.

This time is called the “early warning time,” expressed in microseconds, and determines the protection radius of the lightning protection system.

ACTIVE LIGHTNING PROTECTION RADIUS

Table of Maximum Protection Radius Possible According to NFC 17-102:

Protection Level	I	II	III	IV
Protection Radius, $\Delta t=60 \mu s$	79m	87m	97m	107m

In laboratory environments, larger protection radii are obtained, but relevant standards do not accept protection radii larger than those in the table above for safety reasons.



!!! Please be cautious of companies that promise a large protection radius.

Do not be deceived. !!!

ACTIVE LIGHTNING ROD TESTS

Active lightning rods are designed and manufactured in accordance with TSE 13709 French standard NFC 17-102. To comply with the standards, a lightning rod must successfully pass the following tests in order:

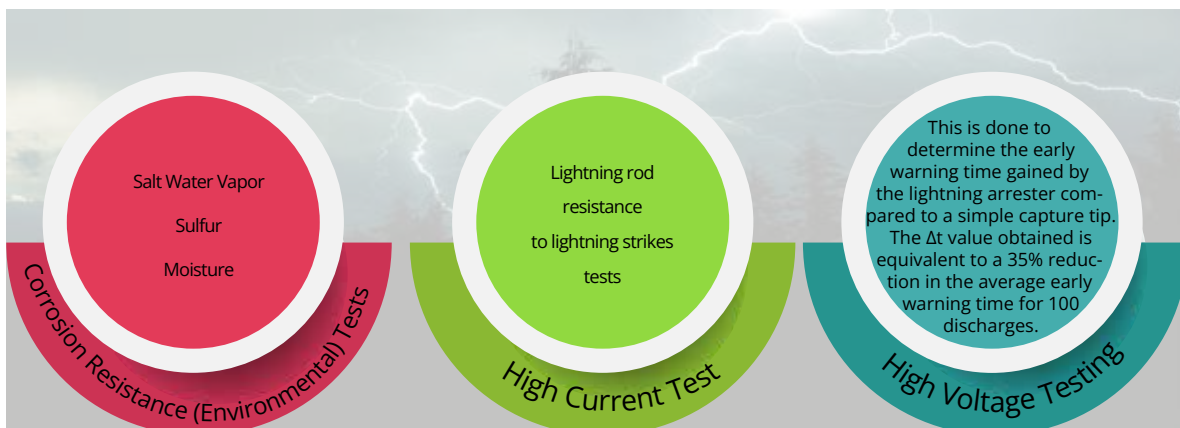

PREVECTRON

TESTED WITH REAL LIGHTNING, THE ONLY LIGHTNING ROD



Real Lightning Test
Performed by Triggering
Lightning with a Rocket



Advanced Technology, NFC 17-102: Compliant with 2011 version!

The ion generator charges using the electric field in the atmospheric area. Thanks to the detection system, the ion generator activates immediately before a lightning discharge and captures the lightning by ionizing the air.

		h(m) Distance from the roof of the building to the lightning rod					
		h(m)	2	3	4	5	10
Protection Level 1	Protection Semi-diameter	S 6.60	31	47	63	79	79
		S 4.50	27	41	55	68	69
		S 3.40	23	36	46	58	59
		TS 3.40	23	36	46	58	59
		TS 2.25	17	24	34	42	44
Protection Level 2	Protection Semi-diameter	h(m)	2	3	4	5	10
		S 6.60	34	52	68	86	88
		S 4.50	30	45	60	76	77
		S 3.40	26	39	52	65	67
		TS 3.40	26	39	52	65	67
TS 2.25	19	29	39	49	51		
Protection Level 3	Protection Semi-diameter	h(m)	2	3	4	5	10
		S 6.60	39	58	78	97	99
		S 4.50	34	52	69	86	88
		S 3.40	30	45	60	75	77
		TS 3.40	30	45	60	75	77
TS 2.25	23	34	46	57	61		
Protection Level 4	Protection Semi-diameter	h(m)	2	3	4	5	10
		S 6.60	43	64	85	107	109
		S 4.50	38	57	76	95	98
		S 3.40	33	50	67	84	87
		TS 3.40	33	50	67	84	87
TS 2.25	26	39	52	65	69		

Counters



Classic Counter
Displays the number of
lightning strikes



Advanced Counter
Lightning Count,
Date, and Lightning
Strength

TESLA

Ultra-High Performance

As a result of lightning strikes applied with the high voltage test system, the early current dissipation feature was determined as $\Delta T = 81 \mu s$. It is 35% higher than the highest level set by international standards.

High Strength

It can withstand lightning strikes of 100 kA applied with a high current test system. Successfully completed tests for resistance to corrosive environments. Successfully tested to withstand extreme weather conditions. Vibration resistant.

IP65

It has high resistance to water and dust. It can be used safely in very rainy and humid regions.

Ultra-High Quality

It has been certified to comply with all national (TS 13709) and international (NFC 17-102:2011) standards. It is produced under a European patent and controlled according to the highest quality standards.

Testable

With the tester, you can test at any time and see that the lightning rod is in working condition. Please keep in mind that lightning rods may get damaged by lightning strikes. Therefore they need to be tested regularly

Long Warranty

Working warranty is 2 years. The operating warranty can be extended with an additional warranty package. There is a 15-year stainless warranty.

Reliable

Each Tesla is tested with the 6-step quality control principle. Tesla is designed and manufactured with Radsan's long years of knowledge and experience. Radsan has produced more than 600.000 lightning rods in 23 years and they are working successfully in more than 100 countries under different conditions.

Complementary Products



Test Device



Aviation Lamp



Counter



ÖZELLİKLER

Model	RADSAN
Kod	TESLA-ST
Early Triggerring Time	60 μs
Test Performance	81 μs
Current Withstand 10/350 μs	100kA
Corrosion Resistance TS 9258 / EN ISO 6988	High Strength
Protection Class (Dust / Water) TS 3033 / EN 60529	IP 65
Working Temperature TS EN 60068-2-1 / TS EN 60068-2-2	-20°C / +60°C
Testable	Yes
Material	Stainless Steel + Aluminium
Pipe Connection	2" Galvanized Pipe
Product Weight	5,6 kg
Diameter x Height	Ø395x806 cm
Package Information	Weight 6,8 kg 57 x 15 x 14.5 cm
Warranty Period	2 Years Functional 15 Years Pysical Deformation

Licon Insulated Conductor



KINETIC

Ideal Performance

As a result of lightning strikes applied with the high voltage test system, the early current dissipation feature was determined as $\Delta T=60$

High Strength

It can withstand lightning strikes of 200 KA applied with a high current test system. It has two times higher strength than the highest level determined by international standards. Resistance to corrosive environments, extreme weather condition withstanding, vibration tests successfully completed.

IP65

It has high resistance to water and dust. It can be used safely in very rainy and humid areas.

High Quality

It has been certified to comply with all national (TS 13709) and international (NFC 17-102:2011) standards.

Testable

With the tester, you can test at any time and see that the lightning rod is in working condition. Please keep in mind that lightning rods may get damaged by lightning strikes. Therefore they need to be tested regularly

Long Warranty

Working warranty is 2 years. The operating warranty can be extended with an additional warranty package. There is a 15-year stainless warranty.

Reliable

Each Kinetic is tested with the 6-step quality control principle. Kinetic Pro is designed and manufactured with Radsan's long years of knowledge and experience. Radsan has produced more than 600.000 lightning rods in 23 years and they are working successfully in more than 100 countries under different conditions.

Complementary Products



ÖZELLİKLER

Model	RADSAN
Kod	KINETIC
Early Triggerring Time	60 μ s
Test Performance	61 μ s
Current Withstand 10/350 μ s	200kA
Corrosion Resistance TS 9258 / EN ISO 6988	High Strength
Protection Class (Dust / Water) TS 3033 / EN 60529	IP 65
Working Temperature TS EN 60068-2-1 / TS EN 60068-2-2	-20°C / +60°C
Testable	Yes
Material	Aluminium
Pipe Connection	2" Galvanized Pipe
Product Weight	840 gr
Diameter x Height	11,5 x 44 cm
Package Information	Weight 1.3 kg 13 x 14 x 55 cm
Warranty Period	2 Years Functional 15 Years Pysical Deformation

Licon Insulated Conductor



KINETIC PRO

High Performance

As a result of lightning strikes applied with the high voltage test system, the early current dissipation feature was determined as $\Delta T = 68 \mu s$. It is 13% higher than the highest level set by international standards.

High Strength

It can withstand lightning strikes of 200 kA applied with a high current test system. It has two times higher strength than the highest level determined by international standards. Successfully completed tests for resistance to corrosive environments. Successfully tested to withstand extreme weather conditions. Vibration resistant.

IP65

It has high resistance to water and dust. It can be used safely in very rainy and humid regions.

High Quality

It has been certified to comply with all national (TS 13709) and international (NFC 17-102:2011) standards.

Testable

With the tester, you can test at any time and see that the lightning rod is in working condition. Please keep in mind that lightning rods may get damaged by lightning strikes. Therefore they need to be tested regularly.

Long Warranty

Working warranty is 2 years. The operating warranty can be extended with an additional warranty package. There is a 15-year stainless warranty.

Reliable

Each Kinetic Pro is tested with the 6-step quality control principle. Kinetic Pro is designed and manufactured with Radsan's long years of knowledge and experience. Radsan has produced more than 600.000 lightning rods in 23 years and they are working successfully in more than 100 countries under different conditions.



ÖZELLİKLER

Model	RADSAN
Kod	KINETIC-PRO
Early Triggerring Time	60 μs
Test Performance	68 μs
Current Withstand 10/350 μs	200kA
Corrosion Resistance TS 9258 / EN ISO 6988	High Strength
Protection Class (Dust / Water) TS 3033 / EN 60529	IP 65
Working Temperature TS EN 60068-2-1 / TS EN 60068-2-2	-20°C / +60°C
Testable	Yes
Material	Aluminium
Pipe Connection	2" Galvanized Pipe
Product Weight	1,9 kg
Diameter x Height	14x52 cm
Package Information	Weight 2.4 kg 57 x 15 x 14.5 cm
Warranty Period	2 Years Functional 15 Years Pyshical Deformation

Complementary Products



Licon Insulated Conductor

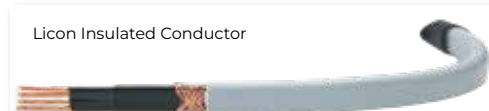

LIGHTNING ROD TEST DEVICE



TS.TC



RAD.TC



INDELEC

Testers test the operability status of lightning rods.

Factors such as lightning, corrosive effects of the external atmosphere, vibration can cause lightning arresters to malfunction. operability status of lightning rods.

Factors such as lightning, corrosive effects of the external atmosphere, vibration can cause lightning arresters to be checked at least once a year.

LIGHTNING COUNTERS



Lightning Strike Counters count the lightning strikes on down conductors, They can detect lightning strikes between 300A and 100 kA.

SMART CODING

Please use the following letter and number Codes to determine the combination of the metal desired product , the coat-ing and the type of bolt-nut group

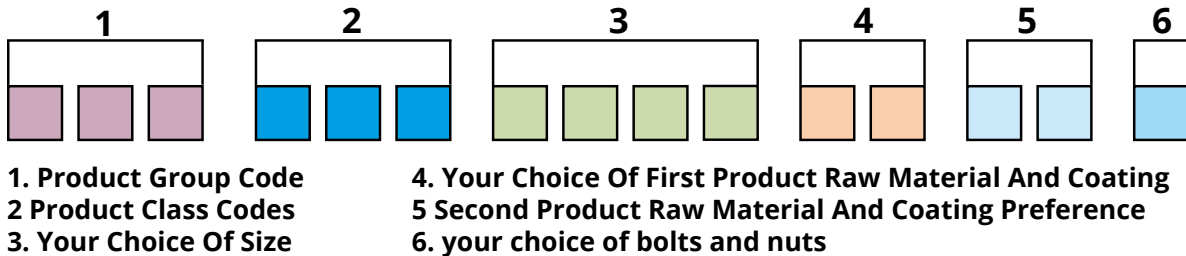

RAW MATERIAL, COATING AND BOLT SELECTION TABLE



RAW MATERIAL		COATING		BOLT	
Code	Explication	Code	Explication	Code	Explication
D	Iron And Steel	1	Electro Galvanized	DC	Galvanized
B	Copper	2	Hot Galvanized	NC	Stainless
N	Stainless	3	Electro Copper	SC	Brass
A	Aluminum	4	Electro Tin		
S	Brass	5	Nickel		
F	Bronze	6	Black isolations		
G	Cast Iron	7	Yellow-green isolation		
P	Plastic				
C	Concrete				

Sample Encodings

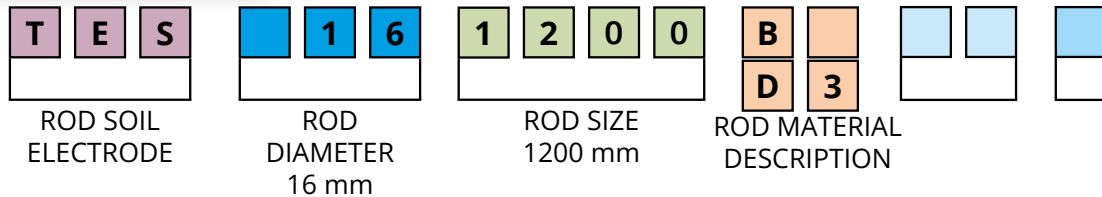

10 µm. Bakır Kaplama/ Coating thickness

Code	Material/Coating	Dia.	Lenght
TES.16.1000	D1-D3-B-N-D2	16 mm	1000 mm
TES.16.1200	D1-D3-B-N-D2	16 mm	1200 mm

Screw Type Conductor Clips

Kod Code	Casing Material/Kaplama Material/Coating	Civata Bolt	İletken Kesit Cross Section
IK.113.04	(D1+A)-(D1+B)-(D1+D1)-(D2+A)(D2+B)(D2+D2)-(N+A)-(N+B)-(N+N)	DC-NC	1x50mm ²
IK.113.05	(D1+A)-(D1+B)-(D1+D1)-(D2+A)(D2+B)(D2+D2)-(N+A)-(N+B)-(N+N)	DC-NC	1x70mm ²
IK.113.06	(D1+A)-(D1+B)-(D1+D1)-(D2+A)(D2+B)(D2+D2)-(N+A)-(N+B)-(N+N)	DC-NC	1x95mm ²



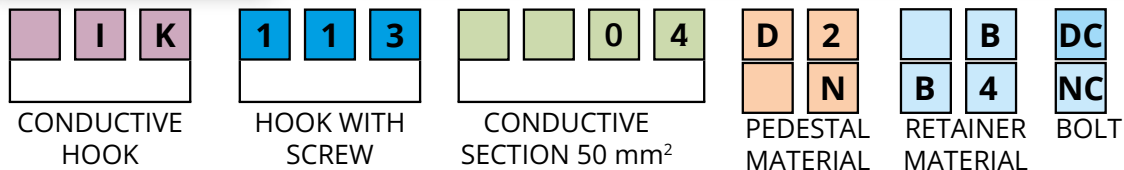

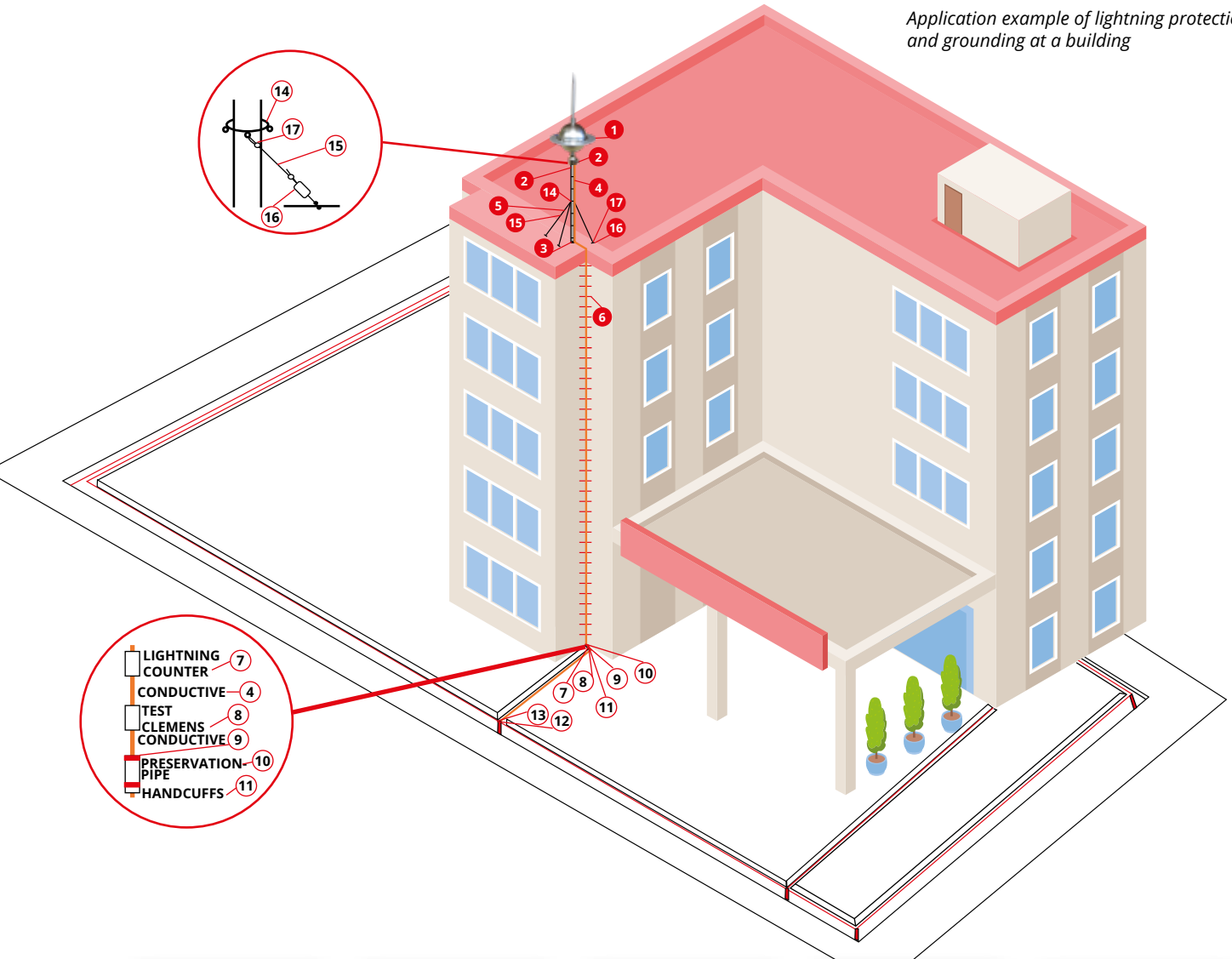

IK.113.04.D2.B.DC SCREW CONDUCTOR CROWN, FOR 50mm² CONDUCTOR, HOT DIP GALVANIZED COATED PEDAL, COPPER HOLDER, GALVANIZED
IK.113.06.N.B4.NC SCREWED CONDUCTOR CROWN, FOR 95mm² CONDUCTOR, STAINLESS STEEL PAPER, TIN COATED COPPER HOLDER, STAINLESS BOLT

APPLICATION EXAMPLE OF LIGHTNING PROTECTION AND GROUNDING AT A BUILDING

Application example of lightning protection and grounding at a building



-  LIGHTNING COUNTER 7
-  CONDUCTIVE TEST CLEMENS CONDUCTIVE 8
-  PRESERVATION PIPE 10
-  HANDCUFFS 11

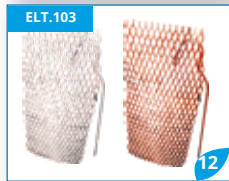
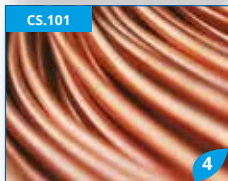

APPLICATION EXAMPLE OF LIGHTNING PROTECTION AND GROUNDING AT A GAS STATION

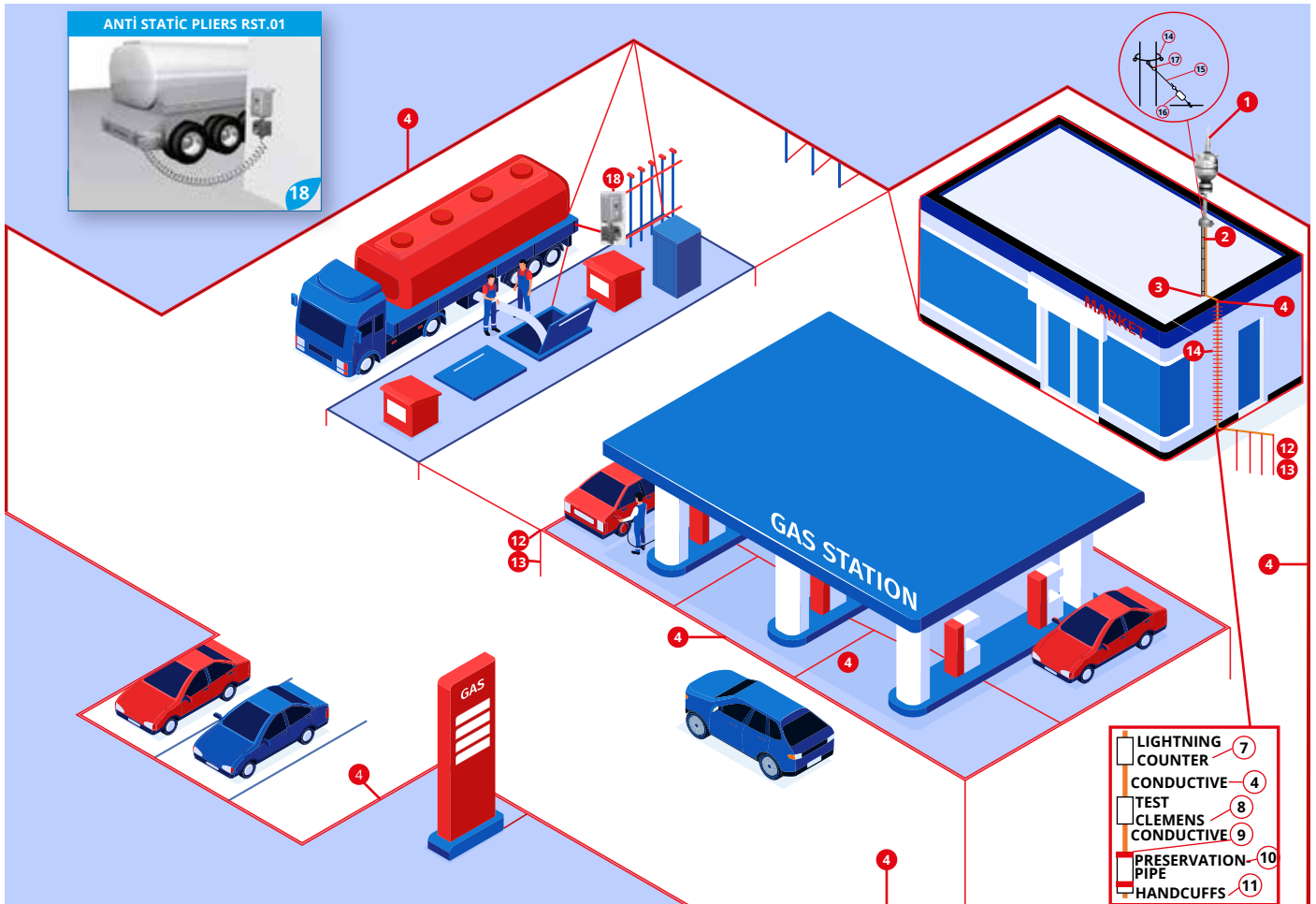

Application example of lightning protection and grounding at a gas station



APPLICATION EXAMPLE OF LIGHTNING PROTECTION AND GROUNDING AT A LATTICE TOWER

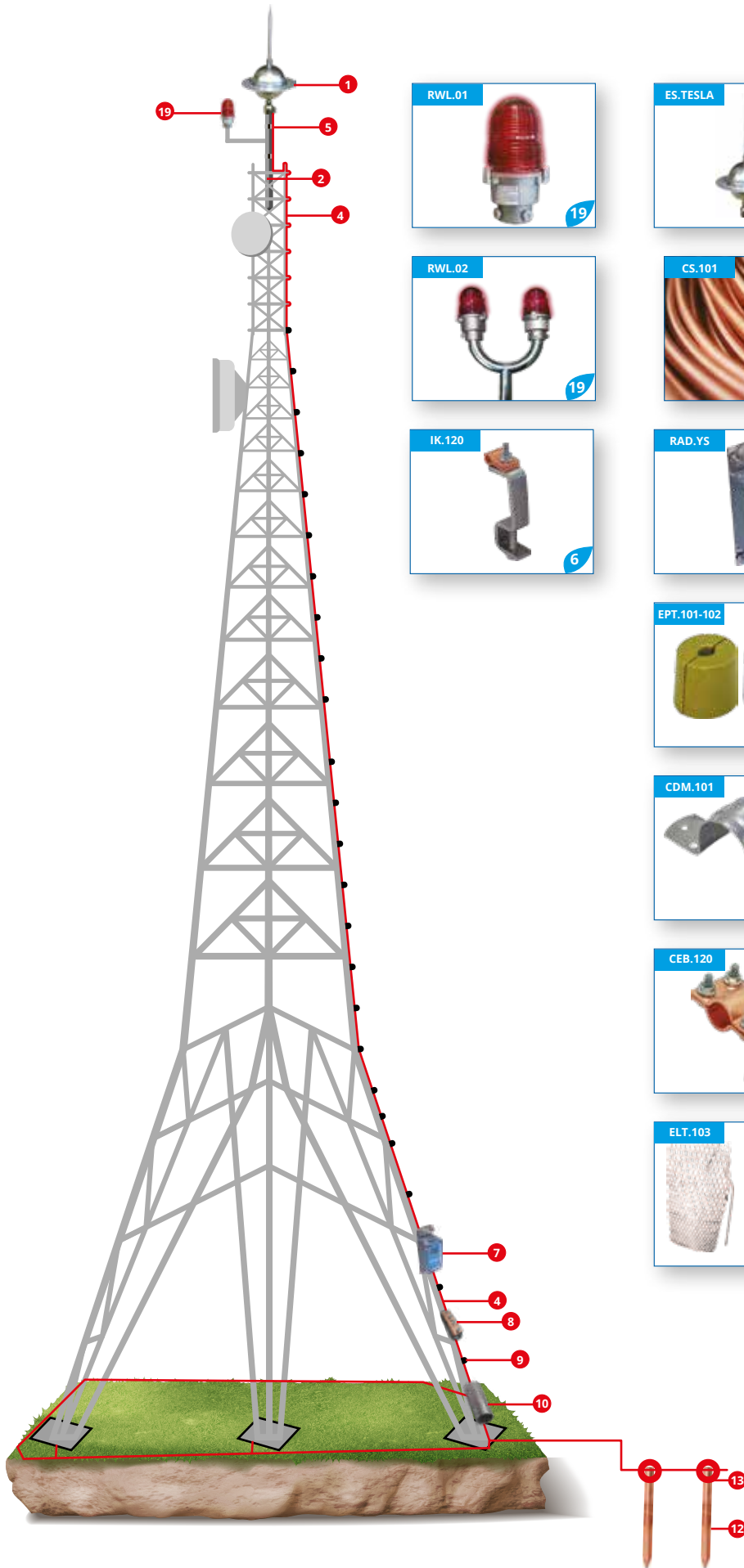

Application example of lightning protection and grounding at a lattice tower

APPLICATION EXAMPLE OF LIGHTNING PROTECTION AND GROUNDING AT A MONOPOLE MAST

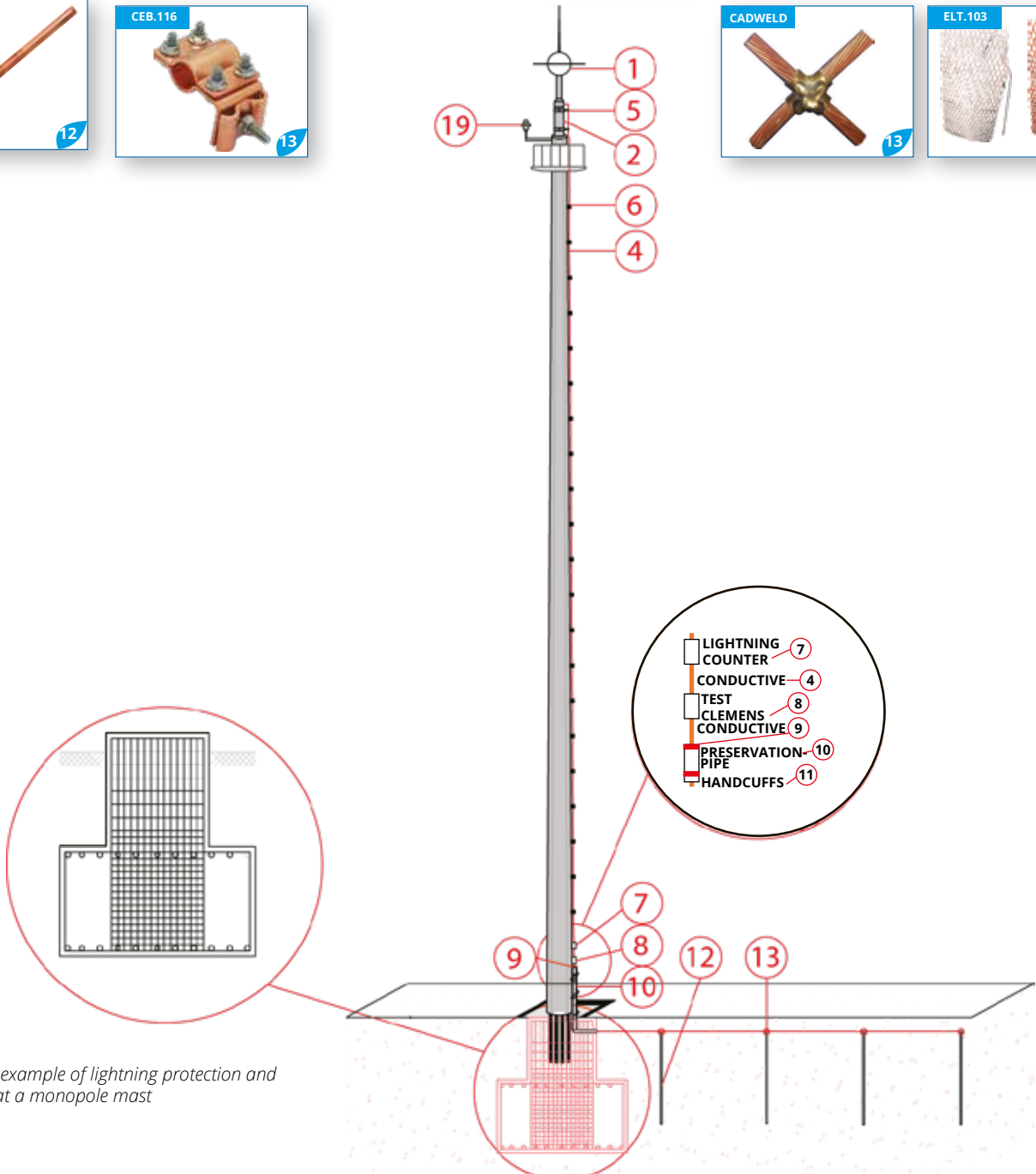

Application example of lightning protection and grounding at a monopole mast

APPLICATION EXAMPLE OF LIGHTNING PROTECTION AND GROUNDING AT A MAST

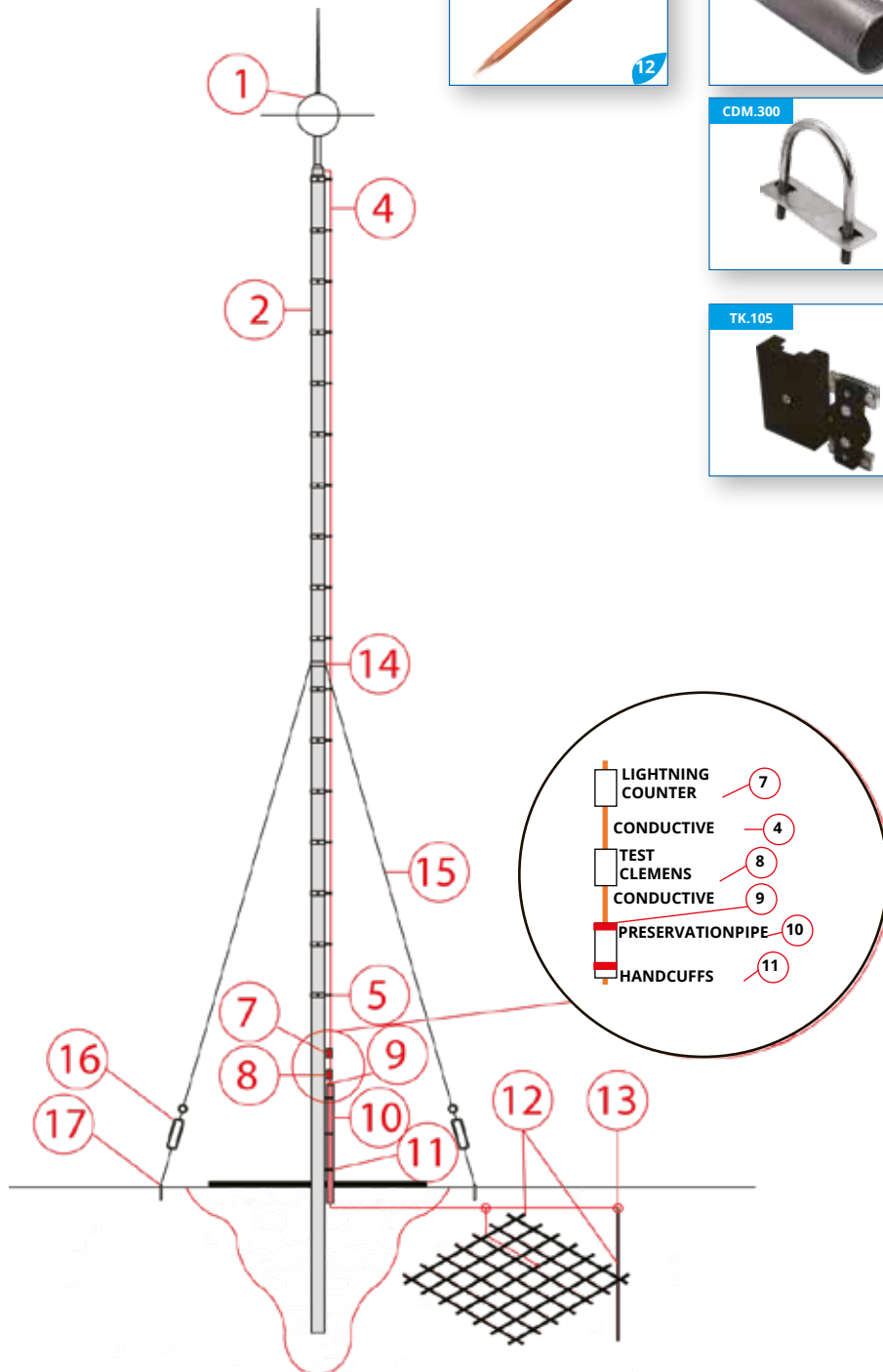

MASTS

Polygon Mast



Code	Material / Coating	Height (mm)
PLG.10	D2	10
PLG.12	D2	12
PLG.14	D2	14
PLG.15	D2	15
PLG.15	D2	16
PLG.18	D2	18
PLG.20	D2	20
PLG.25	D2	25

Fold Over, Short Mast

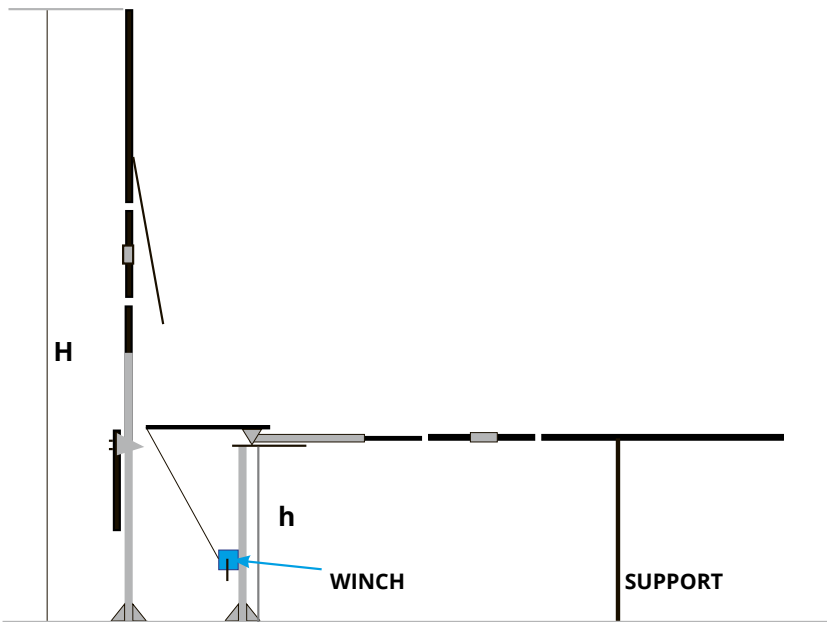

Please add the number corresponding to the "bending"

Code	Material	$\Sigma H(m)$	Folding Height (h), m				
			1,75	2	2,25	2,5	3
FOM.14	D2-A	14				X	X
FOM.12		12			X	X	X
FOM.10		10		X	X	X	X
FOM.08		8	X	X	X	X	X
FOM.06		6	X	X	X	X	X
FOM.04		4	X	X	X	X	X

MAIN MATERIAL
A=Aluminium, B=Copper, D=Iron-Steel,
F=Bronze, G=Gray Cast Iron,
N=Stainless, P=Plastic, S=Brass

COATINGS
1=Electrogalvanizing, 2=Hot Dip Galvanizing, 3=Electrodeposited Copper,
4=Electrodeposited Tin, 5=Electrodeposited Chromium-Nickel,
6=Black Insulation, 7=Yellow-Green Insulation

SCREW NUT
DC=Galvanizing,
NC=Stainless,
SC=Brass

MASTS

Portable Mast

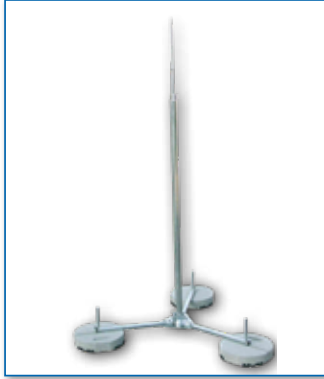

Code	Material Coating	Length (m)	Material / Dia. (mm)								Total Length	
			N/D 289	N/D 250	N/D 242	N/D 234	A 80	A 65	A 40	A 16		A 10
SSM.106.01	D1-D2-N-A	3				1				1	1	3
SSM.106.02		3						1	1	1		3
SSM.106.03	D1-D2-N-A	4				2				1	1	4
SSM.106.04		4						2	1	1		4
SSM.106.05	D1-D2-N-A	5				3				1	1	5
SSM.106.06		5						3	1	1		5
SSM.106.07	D1-D2-N-A	6			2,5	1,5				1	1	6
SSM.106.08		6						4	1	1		6
SSM.106.09	D1-D2-N-A	7			2,5	2,5				1	1	7
SSM.106.10		7						5	1	1		7
SSM.106.11	D1-D2-N-A	8			3,5	2,5				1	1	8
SSM.106.12		8						5,5	1,5	1		8
SSM.106.13	D1-D2-N-A	9		3	2	2				1	1	9
SSM.106.14		9						3,5	3	1,5	1	9
SSM.106.15	D1-D2-N-A	10	4				3	2			1	10
SSM.106.16	D1-D2-N-A	11	4				3	3			1	11
SSM.106.17	D1-D2-N-A	12	4				4	3			1	12
SSM.106.18	D1-D2-N-A	13	5				4	3			1	13
SSM.106.19	D1-D2-N-A	14	5				5	3			1	14

MAIN MATERIAL

A=Aluminium, B=Copper, D=Iron-Steel,
F=Bronze, G=Gray Cast Iron,
N=Stainless, P=Plastic, S=Brass

COATINGS

1=Electrogalvanizing, 2=Hot Dip Galvanizing, 3=Electrodeposited Copper,
4=Electrodeposited Tin, 5=Electrodeposited Chromium-Nickel,
6=Black Insulation, 7=Yellow-Green Insulation

SCREW NUT

DC=Galvanizing,
NC=Stainless,
SC=Brass

LIGHTNING MASTS FOR E.S.E AND AIR ROD (ALTERNATIVE TO POLYGON MASTS.) LLM SERIES LIGHTNING POSTS

Flanged Mast

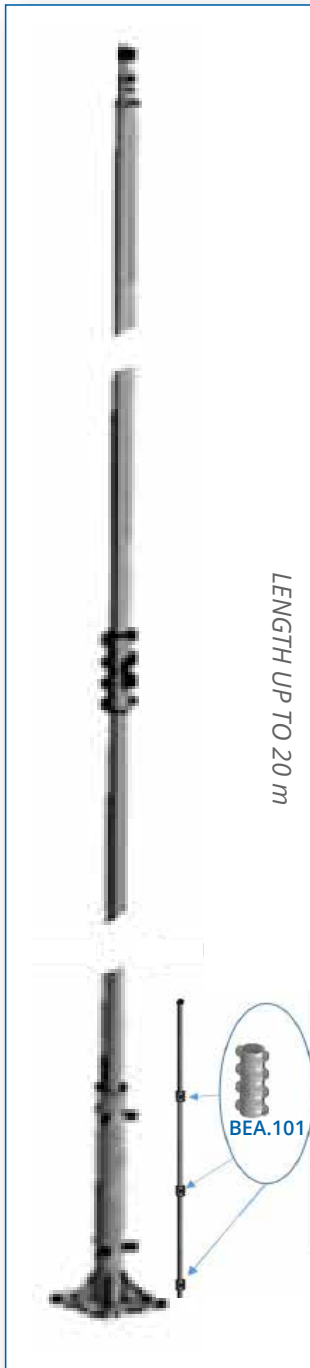

Code	Material	Mast Dia. (mm)			ΣL	Lente Support Wire	
		60	76	89	m		
LLM.1.06	Galvanized Steel	6(3+3)			6		
LLM.2.06			6(3+3)				
LLM.3.06				6(3+3)			
LLM.1.07		1	6		7		
LLM.2.07		1		6			
LLM.3.07		1+6					
LLM.4.07			1+6				
LLM.5.07				1+6			
LLM.1.08			2	6		8	
LLM.2.08		2		6			
LLM.3.08			2	6			
LLM.4.08		2+6					
LLM.5.08			2+6				
LLM.6.08				2+6			
LLM.1.09			3	6		9	
LLM.2.09		3		6			
LLM.3.09			3	6			
LLM.4.09		3+6					
LLM.5.09			3+6				
LLM.6.09				3+6			
LLM.1.10		4	6		10		
LLM.2.10	4		6				
LLM.3.10		4	6				
LLM.4.10	4+6						
LLM.5.10		4+6					
LLM.6.10			4+6				

Lightning rod masts combined with clamps, transportation length may be approximately 3 or 4 m

LIGHTNING ROD INSTALLATION MATERIALS

Lightning Arrester (ESE) Mast



Code	Material / Coating	Dia. (inch)	Lenght
CD.101.05	D2 - N	1.5"	6000 mm
CD.101.06	D2 - N	2"	6000 mm
CD.101.07	D2 - N	2.5"	6000 mm

Mast Joint



Code	Material / Coating	Dia. (inch)	Lenght
BEA.101.01	D2 - N	2"	300 mm
BEA.101.02	D2 - N	2.5"	300 mm

MAIN MATERIAL

A=Aluminium, B=Copper, D=Iron-Steel,
F=Bronze, G=Gray Cast Iron,
N=Stainless, P=Plastic, S=Brass

COATINGS

1=Electrogalvanizing, 2=Hot Dip Galvanizing, 3=Electrodeposited Copper,
4=Electrodeposited Tin, 5=Electrodeposited Chromium-Nickel,
6=Black Insulation, 7=Yellow-Green Insulation

SCREW NUT

DC=Galvanizing,
NC=Stainless,
SC=Brass

LIGHTNING ROD INSTALLATION MATERIALS

Adapter Between E.S.E. and Mast



Code	Material / Coating	Dia. (inch)
PDA.104.01	A	2"

For Tesla-ST and Petex Lightning Arresters

For French Type Lightning Arrester



Code	Material / Coating	Description	Dia. (inch)
PDA.102.01	D1 - D2	Adaptör Adapter	2"
PDA.102.02	D1 - D2	Adaptör Adapter	2"½
PDA.102.03	D1 - D2	Adaptör Adapter	3"

For French Type Lightning Arrester



Code	Material / Coating	Description	Dia. (inch)
PDA.103.01	D1 - D2	Adaptör Adapter	2"
PDA.103.02	D1 - D2	Adaptör Adapter	2"½
PDA.103.03	D1 - D2	Adaptör Adapter	3"

LIGHTNING ROD INSTALLATION MATERIALS

Mast Holder For Flat Surfaces



Kod Code	Material / Coating	Pipe Dia. (inch)
CDT.201.05	D1-D2-N	2"
CDT.201.06	D1-D2-N	2"½
CDT.201.07	D1-D2-N	3"

Mast Holder For Flat Surfaces, Corner Type



Code	Material / Coating	Pipe Dia. (inch)
CDT.301.05	D1-D2-N	2"
CDT.301.06	D1-D2-N	2"½
CDT.301.07	D1-D2-N	3"

Mast Holder For Walls



Code	Material / Coating	Pipe Dia. (inch)
CDT.401.02-07	D1-D2-N	1" - 3"

MAIN MATERIAL

A=Aluminium, B=Copper, D=Iron-Steel,
F=Bronze, G=Gray Cast Iron,
N=Stainless, P=Plastic, S=Brass

COATINGS

1=Electrogalvanizing, 2=Hot Dip Galvanizing, 3=Electrodeposited Copper,
4=Electrodeposited Tin, 5=Electrodeposited Chromium-Nickel,
6=Black Insulation, 7=Yellow-Green Insulation

SCREW NUT

DC=Galvanizing,
NC=Stainless,
SC=Brass

LIGHTNING ROD INSTALLATION MATERIALS

Mast Holder, Rotatable



Code	Material / Coating	Pipe Dia. (inch)
CDT.402.05	D1-D2-N	2"
CDT.402.06	D1-D2-N	2"½
CDT.402.07	D1-D2-N	3"

Mast Clamp For Wall



Code	Material / Coating	Pipe Dia. (inch)
CDT.101.05	D1-D2-N	2"
CDT.101.06	D1-D2-N	2"½
CDT.101.07	D1-D2-N	3"

U Bolt With Bar



Code	Material / Coating	Pipe Dia. (inch)	Nut
CDM.300.00	D1-D2-N	½"	DC-NC
CDM.300.01	D1-D2-N	¾"	DC-NC
CDM.300.02	D1-D2-N	1"	DC-NC
CDM.300.03	D1-D2-N	1" ¼	DC-NC
CDM.300.04	D1-D2-N	1" ½	DC-NC
CDM.300.05	D1-D2-N	2"	DC-NC
CDM.300.06	D1-D2-N	2"½	DC-NC
CDM.300.07	D1-D2-N	3"	DC-NC

LIGHTNING ROD INSTALLATION MATERIALS

Mast / Plone Clamp “Adjustable Type”



Code	Material / Coating	Pipe Dia. (inch)
CDS.100.00	D1-D2-N	½"↔3"

Type U Stud with Pedestal



Code	Material / Coating	Pipe Dia. (inch)
CDS.100.04	D1-D2-N	1" - 3"

Mast Clamp For Wall



Code	Material / Coating	Pipe Dia. (inch)
CDM.101.00	D1-D2-N	½"
CDM.101.01	D1-D2-N	¾"
CDM.101.02	D1-D2-N	1"
CDM.101.03	D1-D2-N	1¼"
CDM.101.04	D1-D2-N	1½"
CDM.101.05	D1-D2-N	2"
CDM.101.06	D1-D2-N	2½"
CDM.101.07	D1-D2-N	3"

MAIN MATERIAL

A=Aluminium, B=Copper, D=Iron-Steel, F=Bronze, G=Gray Cast Iron, N=Stainless, P=Plastic, S=Brass

COATINGS

1=Electrogalvanizing, 2=Hot Dip Galvanizing, 3=Electrodeposited Copper, 4=Electrodeposited Tin, 5=Electrodeposited Chromium-Nickel, 6=Black Insulation, 7=Yellow-Green Insulation

SCREW NUT

DC=Galvanizing, NC=Stainless, SC=Brass

LIGHTNING ROD INSTALLATION MATERIALS

Conductor Holder for Mast



Code	Material / Coated	Bolt Dia.	Cross-Section
IK.122.20.04	(D1+B)-(D1+D1)-(D2+B)-(D2+D2)-(N+B)-(N+N)	DC-NC 2"	1x50mm ²
IK.122.20.05	(D1+B)-(D1+D1)-(D2+B)-(D2+D2)-(N+B)-(N+N)	DC-NC 2"	1x70mm ²
IK.122.20.06	(D1+B)-(D1+D1)-(D2+B)-(D2+D2)-(N+B)-(N+N)	DC-NC 2"	1x95mm ²
IK.122.20.24	(D1+B)-(D1+D1)-(D2+B)-(D2+D2)-(N+B)-(N+N)	DC-NC 2"	2x50mm ²
IK.122.20.25	(D1+B)-(D1+D1)-(D2+B)-(D2+D2)-(N+B)-(N+N)	DC-NC 2"	2x70mm ²
IK.122.20.26	(D1+B)-(D1+D1)-(D2+B)-(D2+D2)-(N+B)-(N+N)	DC-NC 2"	2x95mm ²
IK.122.20.31	(D1+B)-(D1+D1)-(D2+B)-(D2+D2)-(N+B)-(N+N)	DC-NC 2"	20x3-25x5 mm
IK.122.20.32	(D1+B)-(D1+D1)-(D2+B)-(D2+D2)-(N+B)-(N+N)	DC-NC 2"	30x2-30x5 mm
IK.122.20.33	(D1+B)-(D1+D1)-(D2+B)-(D2+D2)-(N+B)-(N+N)	DC-NC 2"	40x3-40x5 mm
IK.122.25.04	(D1+B)-(D1+D1)-(D2+B)-(D2+D2)-(N+B)-(N+N)	DC-NC 2" ¹ / ₂	1x50mm ²
IK.122.25.05	(D1+B)-(D1+D1)-(D2+B)-(D2+D2)-(N+B)-(N+N)	DC-NC 2" ¹ / ₂	1x70mm ²
IK.122.25.06	(D1+B)-(D1+D1)-(D2+B)-(D2+D2)-(N+B)-(N+N)	DC-NC 2" ¹ / ₂	1x95mm ²
IK.122.25.24	(D1+B)-(D1+D1)-(D2+B)-(D2+D2)-(N+B)-(N+N)	DC-NC 2" ¹ / ₂	2x50mm ²
IK.122.25.25	(D1+B)-(D1+D1)-(D2+B)-(D2+D2)-(N+B)-(N+N)	DC-NC 2" ¹ / ₂	2x70mm ²
IK.122.25.26	(D1+B)-(D1+D1)-(D2+B)-(D2+D2)-(N+B)-(N+N)	DC-NC 2" ¹ / ₂	2x95mm ²
IK.122.25.31	(D1+B)-(D1+D1)-(D2+B)-(D2+D2)-(N+B)-(N+N)	DC-NC 2" ¹ / ₂	20x3-25x5 mm
IK.122.25.32	(D1+B)-(D1+D1)-(D2+B)-(D2+D2)-(N+B)-(N+N)	DC-NC 2" ¹ / ₂	30x2-30x5 mm
IK.122.25.33	(D1+B)-(D1+D1)-(D2+B)-(D2+D2)-(N+B)-(N+N)	DC-NC 2" ¹ / ₂	40x3-40x5 mm
IK.122.30.04	(D1+B)-(D1+D1)-(D2+B)-(D2+D2)-(N+B)-(N+N)	DC-NC 3"	1x50mm ²
IK.122.30.05	(D1+B)-(D1+D1)-(D2+B)-(D2+D2)-(N+B)-(N+N)	DC-NC 3"	1x70mm ²
IK.122.30.06	(D1+B)-(D1+D1)-(D2+B)-(D2+D2)-(N+B)-(N+N)	DC-NC 3"	1x95mm ²
IK.122.30.24	(D1+B)-(D1+D1)-(D2+B)-(D2+D2)-(N+B)-(N+N)	DC-NC 3"	2x50mm ²
IK.122.30.25	(D1+B)-(D1+D1)-(D2+B)-(D2+D2)-(N+B)-(N+N)	DC-NC 3"	2x70mm ²
IK.122.30.26	(D1+B)-(D1+D1)-(D2+B)-(D2+D2)-(N+B)-(N+N)	DC-NC 3"	2x95mm ²
IK.122.30.31	(D1+B)-(D1+D1)-(D2+B)-(D2+D2)-(N+B)-(N+N)	DC-NC 3"	20x3-25x5 mm
IK.122.30.32	(D1+B)-(D1+D1)-(D2+B)-(D2+D2)-(N+B)-(N+N)	DC-NC 3"	30x2-30x5 mm
IK.122.30.33	(D1+B)-(D1+D1)-(D2+B)-(D2+D2)-(N+B)-(N+N)	DC-NC 3"	40x3-40x5 mm

MAIN MATERIAL
A=Aluminium, B=Copper, D=Iron-Steel,
F=Bronze, G=Gray Cast Iron,
N=Stainless, P=Plastic, S=Brass

COATINGS
1=Electrogalvanizing, 2=Hot Dip Galvanizing, 3=Electrodeposited Copper,
4=Electrodeposited Tin, 5=Electrodeposited Chromium-Nickel,
6=Black Insulation, 7=Yellow-Green Insulation

SCREW NUT
DC=Galvanizing,
NC=Stainless,
SC=Brass

LIGHTNING ROD INSTALLATION MATERIALS

Conductor Holder for Mast, Isolated



Code	Material / Coating	Bolt	Mast Conductor Dia. (inch)	Cross Section
IKP.122.20.24	(D1+ B)-(D2+ B)-(N+ B) (D1+D1)-(D2+D2)-(N+N)	DC-NC	2"	2x50mm ²
IKP.122.20.25	(D1+ B)-(D2+ B)-(N+ B) (D1+D1)-(D2+D2)-(N+N)	DC-NC	2"	2x70mm ²
IKP.122.20.26	(D1+ B)-(D2+ B)-(N+ B) (D1+D1)-(D2+D2)-(N+N)	DC-NC	2"	2x95mm ²
IKP.122.20.31	(D1+ B)-(D2+ B)-(N+ B) (D1+D1)-(D2+D2)-(N+N)	DC-NC	2"	25x3mm
IKP.122.20.32	(D1+ B)-(D2+ B)-(N+ B) (D1+D1)-(D2+D2)-(N+N)	DC-NC	2"	30x3mm
IKP.122.20.33	(D1+ B)-(D2+ B)-(N+ B) (D1+D1)-(D2+D2)-(N+N)	DC-NC	2"	40x3mm
IKP.122.25.24	(D1+ B)-(D2+ B)-(N+ B) (D1+D1)-(D2+D2)-(N+N)	DC-NC	2" ¹ / ₂	2x50mm ²
IKP.122.25.25	(D1+ B)-(D2+ B)-(N+ B) (D1+D1)-(D2+D2)-(N+N)	DC-NC	2" ¹ / ₂	2x70mm ²
IKP.122.25.26	(D1+ B)-(D2+ B)-(N+ B) (D1+D1)-(D2+D2)-(N+N)	DC-NC	2" ¹ / ₂	2x95mm ²
IKP.122.25.31	(D1+ B)-(D2+ B)-(N+ B) (D1+D1)-(D2+D2)-(N+N)	DC-NC	2" ¹ / ₂	25x3mm
IKP.122.25.32	(D1+ B)-(D2+ B)-(N+ B) (D1+D1)-(D2+D2)-(N+N)	DC-NC	2" ¹ / ₂	30x3mm
IKP.122.30.24	(D1+ B)-(D2+ B)-(N+ B) (D1+D1)-(D2+D2)-(N+N)	DC-NC	3"	2x50mm ²
IKP.122.30.25	(D1+ B)-(D2+ B)-(N+ B) (D1+D1)-(D2+D2)-(N+N)	DC-NC	3"	2x70mm ²
IKP.122.30.26	(D1+ B)-(D2+ B)-(N+ B) (D1+D1)-(D2+D2)-(N+N)	DC-NC	3"	2x95mm ²
IKP.122.30.31	(D1+ B)-(D2+ B)-(N+ B) (D1+D1)-(D2+D2)-(N+N)	DC-NC	3"	25x3mm
IKP.122.30.32	(D1+ B)-(D2+ B)-(N+ B) (D1+D1)-(D2+D2)-(N+N)	DC-NC	3"	30x3mm

MAIN MATERIAL

A=Aluminium, B=Copper, D=Iron-Steel,
F=Bronze, G=Gray Cast Iron,
N=Stainless, P=Plastic, S=Brass

COATINGS

1=Electrogalvanizing, 2=Hot Dip Galvanizing, 3=Electrodeposited Copper,
4=Electrodeposited Tin, 5=Electrodeposited Chromium-Nickel,
6=Black Insulation, 7=Yellow-Green Insulation

SCREW NUT

DC=Galvanizing,
NC=Stainless,
SC=Brass

LIGHTNING ROD INSTALLATION MATERIALS

Clamp For Stretch Wire



Code	Material / Coating	Pipe Dia. (inch)
GE.105.05	D1-D2	2"
GE.105.06	D1-D2	2" ¹ / ₂
GE.105.07	D1-D2	3"

Stretch Wire



Code	Material / Coating	Dia.
GE.104.01	D2 - (D2 + P)	Ø6 mm
GE.104.02	D2 - (D2 + P)	Ø8 mm
GE.104.06	D2 - (D2 + P)	Ø10 mm
GE.104.07	D2 - (D2 + P)	Ø12 mm

Turnbuckle



Code	Material / Coating	Thread Dia.	Leght
GE.101.01	D2	M6	108 mm
GE.101.02	D2	M8	108 mm
GE.101.03	D2	M10	125 mm
GE.101.04	D2	M12	125 mm
GE.101.05	D2	M16	125 mm

LIGHTNING ROD INSTALLATION MATERIALS

Stretch Wire Stake

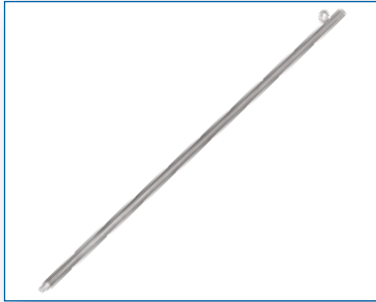

Code	Material / Coating	Leght
GE.102.01	D1-D2-N	Ø16mm - 100cm

Stretch Wire Clamp



Code	Material / Coating	Wire Dia.
GE.103.01	D2	Ø6 mm
GE.103.02	D2	Ø8 mm
GE.103.03	D2	Ø10 mm
GE.103.04	D2	Ø12 mm

Cringle



Code	Material / Coating	Dia.
RDN.101.01	D2	Ø6 mm
RDN.101.02	D2	Ø8 mm
RDN.101.03	D2	Ø10 mm
RDN.101.04	D2	Ø12 mm

MAIN MATERIAL

A=Aluminium, B=Copper, D=Iron-Steel,
F=Bronze, G=Gray Cast Iron,
N=Stainless, P=Plastic, S=Brass

COATINGS

1=Electrogalvanizing, 2=Hot Dip Galvanizing, 3=Electrodeposited Copper,
4=Electrodeposited Tin, 5=Electrodeposited Chromium-Nickel,
6=Black Insulation, 7=Yellow-Green Insulation

SCREW NUT

DC=Galvanizing,
NC=Stainless,
SC=Brass

CLASSICAL METHODS



MESH METHOD

Protection Level	ROD					Mesh Size (m)	Conductor Distance (m)
	Height (m)	20	30	45	60		
I	Angles	25	x	x	x	5 x 5	10
II		35	25	x	x	10 x 10	15
III		45	35	25	x	15 x 15	20
IV		55	45	35	25	20 x 20	25

MAIN MATERIAL
A=Aluminium, B=Copper, D=Iron-Steel,
F=Bronze, G=Gray Cast Iron,
N=Stainless, P=Plastic, S=Brass

COATINGS
1=Electrogalvanizing, 2=Hot Dip Galvanizing, 3=Electrodeposited Copper,
4=Electrodeposited Tin, 5=Electrodeposited Chromium-Nickel,
6=Black Insulation, 7=Yellow-Green Insulation

SCREW NUT
DC=Galvanizing,
NC=Stainless,
SC=Brass

MESH METHOD INSTALLATION EQUIPMENTS

Lightning Rod

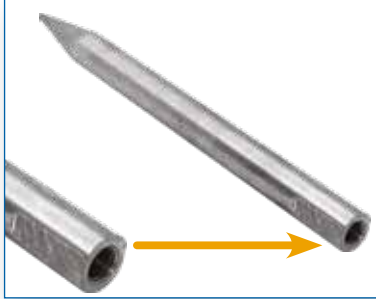

Code	Material / Coating	Dia.	Lenght
FC.416.400	A-B-B5-D1-D2-D5-N	ø16 mm.	400 mm.
FC.416.500	A-B-B5-D1-D2-D5-N	ø16 mm.	500 mm.
FC.416.600	A-B-B5-D1-D2-D5-N	ø16 mm.	600 mm.
FC.416.800	A-B-B5-D1-D2-D5-N	ø16 mm.	800 mm.
FC.420.400	A-B-B5-D1-D2-D5-N	ø20 mm.	400 mm.
FC.420.500	A-B-B5-D1-D2-D5-N	ø20 mm.	500 mm.
FC.420.600	A-B-B5-D1-D2-D5-N	ø20 mm.	600 mm.
FC.420.800	A-B-B5-D1-D2-D5-N	ø20 mm.	800 mm.

Lightning Rod, Long



Code	Material / Coating	Dia.	Lenght
FC.410.1000	A-B-B5-D1-D2-D5-N	Ø10	1000 mm
FC.416.1000	A-B-B5-D1-D2-D5-N	Ø16	1000 mm
FC.416.1250	A-B-B5-D1-D2-D5-N	Ø16	1250 mm
FC.416.1500	A-B-B5-D1-D2-D5-N	Ø16	1500 mm
FC.416.2000	A-B-B5-D1-D2-D5-N	Ø16	2000 mm
FC.416.3000	A-B-B5-D1-D2-D5-N	Ø16	3000 mm
FC.420.1000	A-B-B5-D1-D2-D5-N	Ø20	1000 mm
FC.420.1250	A-B-B5-D1-D2-D5-N	Ø20	1250 mm
FC.420.1500	A-B-B5-D1-D2-D5-N	Ø20	1500 mm
FC.420.2000	A-B-B5-D1-D2-D5-N	Ø20	2000 mm
FC.420.3000	A-B-B5-D1-D2-D5-N	Ø20	3000 mm

Lightning Rod "Mushroom Shaped"



Code	Material / Coating
FC.501.01	B5-D5-N

MAIN MATERIAL

A=Aluminium, B=Copper, D=Iron-Steel,
F=Bronze, G=Gray Cast Iron,
N=Stainless, P=Plastic, S=Brass

COATINGS

1=Electrogalvanizing, 2=Hot Dip Galvanizing, 3=Electrodeposited Copper,
4=Electrodeposited Tin, 5=Electrodeposited Chromium-Nickel,
6=Black Insulation, 7=Yellow-Green Insulation

SCREW NUT

DC=Galvanizing,
NC=Stainless,
SC=Brass

MESH METHOD INSTALLATION EQUIPMENTS

Lightning Rod With Multiple Points



Code	Material / Coating	Dia.
FC.616.01	S5	16 mm
FC.616.02	S5	20 mm

Catching Tip "Extension Bar"



Code	Material / Coating	Dia.	Lenght
FYB.16.500	D5 - S5	16 mm	500 mm
FYB.16.1000	D5 - S5	16 mm	1000 mm
FYB.16.1500	D5 - S5	16 mm	1500 mm
FYB.20.500	D5 - S5	20 mm	500 mm
FYB.20.1000	D5 - S5	20 mm	1000 mm
FYB.20.1500	D5 - S5	20 mm	1500 mm

Lightning Rod with Cadweld Joint



Code	Material / Coating	Dia.	Lenght
ER.116.600	B-B5-D5-N	16 mm	600 mm
ER.116.800	B-B5-D5-N	16 mm	800 mm
ER.120.600	B-B5-D5-N	20 mm	600 mm
ER.120.800	B-B5-D5-N	20 mm	800 mm

Lightning Rod Holder



Code	Material / Coating	Connection Female
ERB.302.01	D1-D2-N	M12

MAIN MATERIAL
A=Aluminium, B=Copper, D=Iron-Steel,
F=Bronze, G=Gray Cast Iron,
N=Stainless, P=Plastic, S=Brass

COATINGS
1=Electrogalvanizing, 2=Hot Dip Galvanizing, 3=Electrodeposited Copper,
4=Electrodeposited Tin, 5=Electrodeposited Chromium-Nickel,
6=Black Insulation, 7=Yellow-Green Insulation

SCREW NUT
DC=Galvanizing,
NC=Stainless,
SC=Brass

MESH METHOD INSTALLATION EQUIPMENTS

Lightning Rod Holder "Slope Adjustable"



Code	Material / Coating
ERB.303.01	D1-D2-N

Lightning Rod Holder "Concrete"



Code	Material / Coating	Weight
FT.500	C	9270 gr

Lightning Rod Holder "Rod Diameter Adjustable"

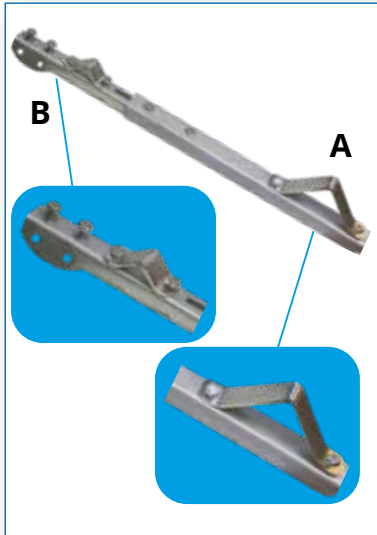

Code	Material / Coating	A- Dia.	B- Rod Dia.
FTS.106.10	D1-D2-N	1" - 3" inç	16 -20 mm

MAIN MATERIAL

A=Aluminium, B=Copper, D=Iron-Steel,
F=Bronze, G=Gray Cast Iron,
N=Stainless, P=Plastic, S=Brass

COATINGS

1=Electrogalvanizing, 2=Hot Dip Galvanizing, 3=Electrodeposited Copper,
4=Electrodeposited Tin, 5=Electrodeposited Chromium-Nickel,
6=Black Insulation, 7=Yellow-Green Insulation

SCREW NUT

DC=Galvanizing,
NC=Stainless,
SC=Brass

MESH METHOD INSTALLATION EQUIPMENTS

Lightning Rod Holder for Walls



Code	Material / Coating	Size
FT.502	D1-D2-N	MAX. 100 cm

Lightning Rod Holder for Walls "Isolated"

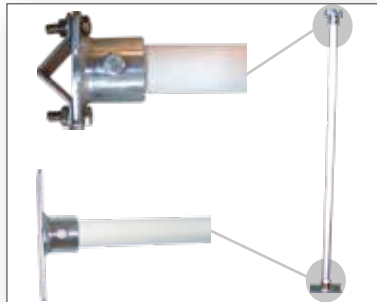

Code	Material / Coating	Lenght
FT.503	(P+D1) - (P+D2) - (P+N)	MAX. 100 cm

Lightning Rod Holder "Plus Type"



Code	Material / Coating	Civata Bolt	Cross Section
FT.101.01	S-S4	NC-SC	50 mm ²
FT.101.02	S-S4	NC-SC	70 mm ²
FT.101.03	S-S4	NC-SC	95 mm ²

MESH METHOD INSTALLATION EQUIPMENTS

Lightning Rod Holder "Block Type"



Code	Material / Coating	Bolt	Cross Section
FT.103.01	(B+S)-B4+S	NC-SC	50 mm ²
FT.103.02	(B+S)-B4+S	NC-SC	70 mm ²

Base for Plus&Block Type Lightning Rod Holder



Code	Material / Coating	Thread
FTS.103.01	D1-D2-N	M12

Base for Plus&Block Type Lightning Rod Holder



Code	Material / Coating	Thread
FTS.105.01	D1-D2-N	M12

MAIN MATERIAL

A=Aluminium, B=Copper, D=Iron-Steel,
F=Bronze, G=Gray Cast Iron,
N=Stainless, P=Plastic, S=Brass

COATINGS

1=Electrogalvanizing, 2=Hot Dip Galvanizing, 3=Electrodeposited Copper,
4=Electrodeposited Tin, 5=Electrodeposited Chromium-Nickel,
6=Black Insulation, 7=Yellow-Green Insulation

SCREW NUT

DC=Galvanizing,
NC=Stainless,
SC=Brass

MESH METHOD INSTALLATION EQUIPMENTS

Plastic Base for Plus&Block Type Lightning Rod Holder "Can be glued"



Code	Material/Coating	Bolt
IPK.201.01	P	M8

Lightning Rod Holder "Screw Type"



Code	Material/Coating	Bolt	Cross Section
FT.102.01	(D1+D1)-(D2+A)-(D1+B)-(D2+B)-(N+N)	DC-NC	50 mm ²
FT.102.02	(D1+D1)-(D2+A)-(D1+B)-(D2+B)-(N+N)	DC-NC	70 mm ²
FT.102.03	(D1+D1)-(D2+A)-(D1+B)-(D2+B)-(N+N)	DC-NC	95 mm ²
FT.102.04	(D1+D1)-(D2+A)-(D1+B)-(D2+B)-(N+N)	DC-NC	120mm ²

Lightning Rod Holder "Mast Hat"



Code	Material/Coating	Mast Diameter (inch)
FTS.108.01	D1-D2-N	2"
FTS.108.02	D1-D2-N	2.5"
FTS.108.03	D1-D2-N	3"

MESH METHOD INSTALLATION EQUIPMENTS

Lightning Rod Holder for Mast Coupling



Code	Material / Coating	Mast Diameter (inch)
FTS.111.01	D1-D2-N	2"
FTS.111.02	D1-D2-N	2 1/2"
FTS.111.03	D1-D2-N	3"

Lightning Rod Holder For Flat Surfaces



Code	Material / Coating	Bolt	Cond. Size	Thread
FT.201.01	(D1+B)-(D1+D1) (D2+B)-(D2+D2)-(N+N)	DC-NC	50 mm ²	M12
FT.201.02	(D1+B)-(D1+D1) (D2+B)-(D2+D2)-(N+N)	DC-NC	70 mm ²	M12
FT.201.03	(D1+B)-(D1+D1) (D2+B)-(D2+D2)-(N+N)	DC-NC	95 mm ²	M12

Lightning Rod Holder For Flat Surfaces



Code	Material / Coating	Bolt	Cond. Size	Thread
FT.202.01	(D1+B)-(D1+D1) (D2+B)-(D2+D2)-(N+N)	DC-NC	50 mm ²	M12
FT.202.02	(D1+B)-(D1+D1) (D2+B)-(D2+D2)-(N+N)	DC-NC	70 mm ²	M12
FT.202.03	(D1+B)-(D1+D1) (D2+B)-(D2+D2)-(N+N)	DC-NC	95 mm ²	M12

MAIN MATERIAL

A=Aluminium, B=Copper, D=Iron-Steel,
F=Bronze, G=Gray Cast Iron,
N=Stainless, P=Plastic, S=Brass

COATINGS

1=Electrogalvanizing, 2=Hot Dip Galvanizing, 3=Electrodeposited Copper,
4=Electrodeposited Tin, 5=Electrodeposited Chromium-Nickel,
6=Black Insulation, 7=Yellow-Green Insulation

SCREW NUT

DC=Galvanizing,
NC=Stainless,
SC=Brass

MESH METHOD INSTALLATION EQUIPMENTS

Lightning Rod Holder For Flat Surfaces



Code	Material / Coating	Bolt	Cond. Size	Thread
FT.205.01	(D1+B)-(D1+D1) (D2+B)-(D2+D2)-(N+N)	DC-NC	20x3 - 20x5 mm	M12
FT.205.02		DC-NC	25x3 - 25x5 mm	M12
FT.205.03		DC-NC	30x3 - 30x5 mm	M12
FT.205.04		DC-NC	40x3 - 40x5 mm	M12

Lightning Rod Holder For Flat Surfaces



Code	Material / Coating	Bolt	Cond. Size	Thread
FT.210.01	(D1+F)-(D1+S)-(D2+F) (D2+S)-(N+F)-(N+S)	DC-NC	20x3 mm	M12
FT.210.02	(D1+F)-(D1+S)-(D2+F) (D2+S)-(N+F)-(N+S)	DC-NC	25x3 mm	M12
FT.210.03	(D1+F)-(D1+S)-(D2+F) (D2+S)-(N+F)-(N+S)	DC-NC	30x3 mm	M12

Lightning Rod Holder "Slope Adjustable"



Code	Material / Coating	Bolt	Cond. Size	Thread
FT.301.01	(D1+B)-(D1+D1) (D2+B)-(D2+D2)-(N+N)	DC-NC	2x50/ 2x70 mm ²	M12
FT.301.02	(D1+B)-(D1+D1) (D2+B)-(D2+D2)-(N+N)	DC-NC	2x95 mm ²	
FT.301.03	(D1+B)-(D1+D1) (D2+B)-(D2+D2)-(N+N)	DC-NC	2x120 mm ²	

MAIN MATERIAL

A=Aluminium, B=Copper, D=Iron-Steel,
F=Bronze, G=Gray Cast Iron,
N=Stainless, P=Plastic, S=Brass

COATINGS

1=Electrogalvanizing, 2=Hot Dip Galvanizing, 3=Electrodeposited Copper,
4=Electrodeposited Tin, 5=Electrodeposited Chromium-Nickel,
6=Black Insulation, 7=Yellow-Green Insulation

SCREW NUT

DC=Galvanizing,
NC=Stainless,
SC=Brass

MESH METHOD INSTALLATION EQUIPMENTS

Lightning Rod Holder "Slope Adjustable"



Code	Material / Coating	Bolt	Cond. Size	Thread
FT.303.01	(D1+B)-(D1+D1) (D2+B)-(D2+D2)-(N+N)	DC-NC	2x50 mm ² 2x70 mm ²	M12
FT.303.02	(D1+B)-(D1+D1) (D2+B)-(D2+D2)-(N+N)	DC-NC	2x95 mm ²	
FT.303.03	(D1+B)-(D1+D1) (D2+B)-(D2+D2)-(N+N)	DC-NC	2x120 mm ²	

Lightning Rod Holder "Slope Adjustable"

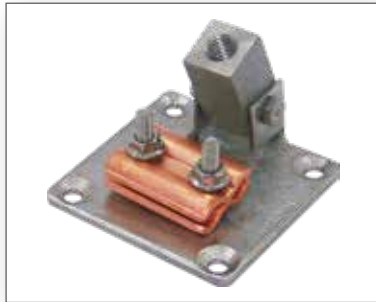

Code	Material / Coating	Bolt	Cond. Size	Thread
FT.306.01	(D1+B)-(D1+D1) (D2+B)-(D2+D2)-(N+N)	DC-NC	2x50 mm ²	M12
FT.306.02	(D1+B)-(D1+D1) (D2+B)-(D2+D2)-(N+N)	DC-NC	2x70 mm ²	
FT.306.03	(D1+B)-(D1+D1) (D2+B)-(D2+D2)-(N+N)	DC-NC	2x95 mm ²	

Lightning Rod Holder "Slope Adjustable"



Code	Material / Coating	Bolt	Cond. Size	Thread
FT.308.01	(D1+B)-(D1+D1) (D2+B)-(D2+D2)-(N+N)	DC-NC	2x50 mm ² 2x70 mm ²	M12
FT.308.02	(D1+B)-(D1+D1) (D2+B)-(D2+D2)-(N+N)	DC-NC	2x95 mm ²	
FT.308.03	(D1+B)-(D1+D1) (D2+B)-(D2+D2)-(N+N)	DC-NC	2x120 mm ²	

MAIN MATERIAL

A=Aluminium, B=Copper, D=Iron-Steel,
F=Bronze, G=Gray Cast Iron,
N=Stainless, P=Plastic, S=Brass

COATINGS

1=Electrogalvanizing, 2=Hot Dip Galvanizing, 3=Electrodeposited Copper,
4=Electrodeposited Tin, 5=Electrodeposited Chromium-Nickel,
6=Black Insulation, 7=Yellow-Green Insulation

SCREW NUT

DC=Galvanizing,
NC=Stainless,
SC=Brass

MESH METHOD INSTALLATION EQUIPMENTS

Lightning Rod Holder For Walls and Chimneys



Code	Material / Coating	Bolt	Cond. Size	Thread
FT.402.01	(D1+B)-(D2+B)-(D1+D1) (D2+D2)-(N+N)	DC-NC	2x50 mm ²	M12
FT.402.02	(D1+B)-(D2+B)-(D1+D1) (D2+D2)-(N+N)	DC-NC	2x70 mm ²	
FT.402.03	(D1+B)-(D2+B)-(D1+D1) (D2+D2)-(N+N)	DC-NC	2x95 mm ²	

Lightning Rod Holder For Clamp Roofs



Code	Material / Coating	Bolt	Cond. Size	Thread
FT.307.01	(B+B)-(D1+B)-(D1+D1) (D2+B)-(D2+D2)-(N+N)	DC-NC	2x50 mm ² 2x70 mm ²	M12
FT.307.02	(B+B)-(D1+B)-(D1+D1) (D2+B)-(D2+D2)-(N+N)	DC-NC	2x95 mm ²	M12
FT.307.01	(B+B)-(D1+B)-(D1+D1) (D2+B)-(D2+D2)-(N+N)	DC-NC	2x120 mm ²	M12

Lightning Rod Holder For Clamp Roofs



Code	Material / Coating	Bolt	Cross Section
FT.204.01	(D1+A)-(D1+B)-(D2+A)-(D2+B) (D1+D1)-(D2+D2)-(N+N)	DC-NC	2x50 mm ² 2x70 mm ²
FT.204.02	(D1+A)-(D1+B)-(D2+A)-(D2+B) (D1+D1)-(D2+D2)-(N+N)	DC-NC	2x95 mm ²
FT.204.03	(D1+A)-(D1+B)-(D2+A)-(D2+B) (D1+D1)-(D2+D2)-(N+N)	DC-NC	2x120 mm ²

MAIN MATERIAL

A=Aluminium, B=Copper, D=Iron-Steel,
F=Bronze, G=Gray Cast Iron,
N=Stainless, P=Plastic, S=Brass

COATINGS

1=Electrogalvanizing, 2=Hot Dip Galvanizing, 3=Electrodeposited Copper,
4=Electrodeposited Tin, 5=Electrodeposited Chromium-Nickel,
6=Black Insulation, 7=Yellow-Green Insulation

SCREW NUT

DC=Galvanizing,
NC=Stainless,
SC=Brass

MESH METHOD INSTALLATION EQUIPMENTS

Lightning Rod Holder For Roof Ridges



Code	Material / Coating	Bolt	Cross Section
FT-312.01	(D1+A)-(D1+B)-(D2+A) (D2+B)-(D1+D1) (D2+D2)-(N+N)	DC-NC	2x50 mm ²
FT-312.02		DC-NC	2x70 mm ²
FT-312.03		DC-NC	2x95 mm ²
FT-312.04		DC-NC	20x3 mm
FT-312.05		DC-NC	30x3 mm
FT-312.06		DC-NC	40x3 mm

Lightning Rod Holder For Roof Ridges



Code	Material / Coating	Bolt	Cross Section
FT.207.01	B - D1 - D2 - N	DC-NC	2x50 mm ²
FT.207.02			2x70 mm ²
FT.207.03		DC-NC	2x120 mm ²

Lightning Rod Holder For Roof Tiles



Code	Material / Coating	Bolt	Cross Section
FT.209.01	B - D1 - D2 - N	DC-NC	2x50 mm ²
FT.209.02			2x70 mm ²
FT.209.03		DC-NC	2x120 mm ²

MAIN MATERIAL

A=Aluminium, B=Copper, D=Iron-Steel,
F=Bronze, G=Gray Cast Iron,
N=Stainless, P=Plastic, S=Brass

COATINGS

1=Electrogalvanizing, 2=Hot Dip Galvanizing, 3=Electrodeposited Copper,
4=Electrodeposited Tin, 5=Electrodeposited Chromium-Nickel,
6=Black Insulation, 7=Yellow-Green Insulation

SCREW NUT

DC=Galvanizing,
NC=Stainless,
SC=Brass

MESH METHOD INSTALLATION EQUIPMENTS

Lightning Rod Holder For Roof Ridges



Code	Material / Coating	Bolt	Thread
FT.206.01	D1 - D2 - N	DC-NC	M12

Lightning Rod Holder For Roof Ridges "Robust"



Code	Material / Coating	Bolt	Thread
FT.214.01	D1 - D2 - N	DC-NC	M12

Lightning Rod Holder For Roof Tiles

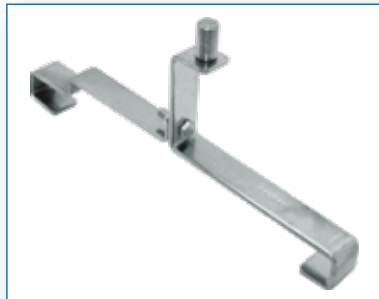

Code	Material / Coating	Bolt	Thread
FT.208.01	D1 - D2 - N	DC-NC	M12

MAIN MATERIAL
 A=Aluminium, B=Copper, D=Iron-Steel,
 F=Bronze, G=Gray Cast Iron,
 N=Stainless, P=Plastic, S=Brass

COATINGS
 1=Electrogalvanizing, 2=Hot Dip Galvanizing, 3=Electrodeposited Copper,
 4=Electrodeposited Tin, 5=Electrodeposited Chromium-Nickel,
 6=Black Insulation, 7=Yellow-Green Insulation

SCREW NUT
 DC=Galvanizing,
 NC=Stainless,
 SC=Brass

STRETCH WIRE METHOD

STRETCH WIRE CONDUCTOR METHOD CATENARY WIRES

This is a protected volume creating method defined by rolling sphere and angle method under a stretched conductor. The "s" critical space ($s=ki.(kc/km)$) between the object to be protected and the stretch conductors due to the sagging should be calculated carefully.

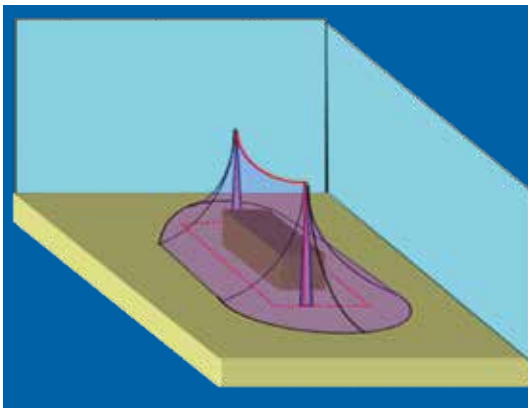

Protection Volume of Stretched Wire Technique

Stretch Wire Techniques

At the applications which are hard to use air rods, stretch wire technique is preferred for economical and easy applications

SWT is applied to additional devices (cooling and ventilation equipment etc.) on the roofs of large commercial buildings and small warehouses and tanks containing inflammable, detonating or combustible materials.

The Lightning Protection Standard EN/IEC 62305 published in 2006 specifically defines the protection of certain structures by an installation insulated from the building. These structures mainly include the explosive material warehouses.

The application is performed by non-isolated conductors stretched on the Masts having a distance from the structure same as the 'S' separation distance calculated according to the EN/IEC 62305-3/6.3. Similarly, the approximation distance of the wire to the structure should be calculated according to the EN/IEC 62305-3/6.3 by considering the sagging (deflection) of the wire stretched on the structure, and any extension and shortening due to the seasonal temperature differences that may affect this distance should also be taken into account.

Given the uncertainties that may be encountered during the calculation of the "S" separation distance, we can calculate the separation distance by a different approach and examine the result. The different values for the 'k' factors to be used in the calculation of the "S" separation distance can lead us to different conclusions. This causes us to undertake a major risk.

STRETCH WIRE METHOD

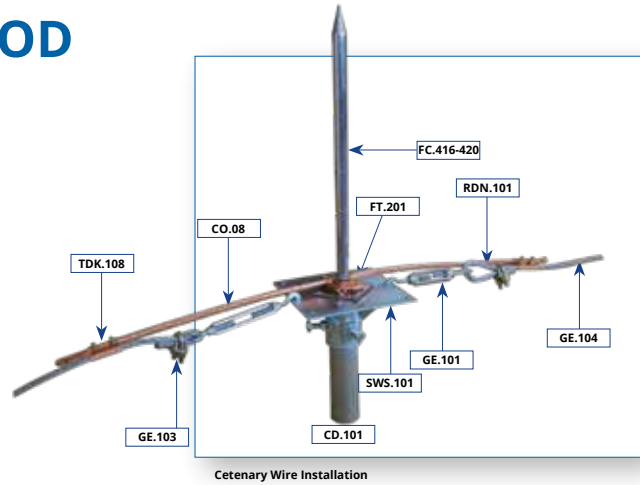

Mast Cap

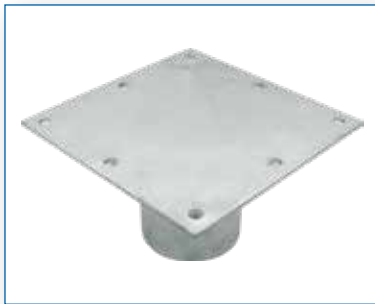

Code	Material / Coating	Dia. (inch)
SWS.101.06	D1-D2-N	2"
SWS.101.07	D1-D2-N	2"½
SWS.101.08	D1-D2-N	3"
SWS.101.09	D1-D2-N	4"
SWS.101.10	D1-D2-N	5"

Mast



Code	Material / Coating	Dia. (inch)	Length
CD.101.01	D2	½"	6000 mm
CD.101.02	D2	¾"	6000 mm
CD.101.03	D2	1"	6000 mm
CD.101.04	D2	1"¼	6000 mm
CD.101.15	D2	1.5"	6000 mm
CD.101.06	D2	2"	6000 mm
CD.101.07	D2	2"½	6000 mm
CD.101.08	D2	3"	6000 mm
CD.101.09	D2	4"	6000 mm
CD.101.10	D2	5"	6000 mm

Insulated Mast Clamp



Code	Material / Coating	Bolt	Mast Dia. (inch)	Conductor Cross Section
IKP.122.20.24	(D1+ B)-(D2+ B)-(N+ B) (D1+D1)-(D2+D2)-(N+N)	DC-NC	2	2x50mm ²
IKP.122.20.25		DC-NC	2	2x70mm ²
IKP.122.20.26		DC-NC	2	2x95mm ²
IKP.122.20.31		DC-NC	2	25x3mm
IKP.122.20.32		DC-NC	2	30x3mm
IKP.122.20.33		DC-NC	2	40x3mm
IKP.122.25.24		DC-NC	2"½	2x50mm ²
IKP.122.25.25		DC-NC	2"½	2x70mm ²
IKP.122.25.26		DC-NC	2"½	2x95mm ²
IKP.122.25.31		DC-NC	2"½	25x3mm
IKP.122.25.32		DC-NC	2"½	30x3mm
IKP.122.30.24		DC-NC	3"	2x50mm ²
IKP.122.30.25		DC-NC	3"	2x70mm ²
IKP.122.30.26		DC-NC	3"	2x95mm ²
IKP.122.30.31		DC-NC	3"	25x3mm
IKP.122.30.32		DC-NC	3"	30x3mm

MAIN MATERIAL

A=Aluminium, B=Copper, D=Iron-Steel, F=Bronze, G=Gray Cast Iron, N=Stainless, P=Plastic, S=Brass

COATINGS

1=Electrogalvanizing, 2=Hot Dip Galvanizing, 3=Electrodeposited Copper, 4=Electrodeposited Tin, 5=Electrodeposited Chromium-Nickel, 6=Black Insulation, 7=Yellow-Green Insulation

SCREW NUT

DC=Galvanizing, NC=Stainless, SC=Brass

STRETCH WIRE METHOD

Lightning Rod



Code	Material / Coating	Dia.	Lenght
FCL.110.1000	A	10 mm	1000 mm

Lightning Rod Adapter



Code	Material / Coating	Description
FCA.110.02	A - B4 - D2 - N	Ø50 / 2" /M12 Adaptor
FCA.110.03	A - B4 - D2 - N	Ø50 / ¾" /M12 Adaptor

Insulated Mast



Code	Material / Coating	Dia.	Lenght
PKB.50.3000	Polyester PVC Kapli	50 mm	3000 mm
PKB.50.4500	PVC Coating Polyester	50 mm	4500 mm

Concrete Base for Insulated Mast



Code	Material / Coating	Description
PKA.002.01	D2+C - N+C	
PKA.002.02	N - N+C	Ø20

MAIN MATERIAL

A=Aluminium, B=Copper, D=Iron-Steel, F=Bronze, G=Gray Cast Iron, N=Stainless, P=Plastic, S=Brass

COATINGS

1=Electrogalvanizing, 2=Hot Dip Galvanizing, 3=Electrodeposited Copper, 4=Electrodeposited Tin, 5=Electrodeposited Chromium-Nickel, 6=Black Insulation, 7=Yellow-Green Insulation

SCREW NUT

DC=Galvanizing, NC=Stainless, SC=Brass

STRETCH WIRE METHOD

Hanger



Code	Material / Coating	Thread	Cross Section
FCA.210.10	D1-D2-N	M10	
FCA.210.100.04	D1-D2-N		50 mm ²
FCA.210.100.06	D1-D2-N		95 mm ²

Aluminium Conductor For Stretch Wire



Code	Material / Coating	Cross Section	Weight (kg/m)
ALS-08.08	A	50 mm ²	0,137
ALS-08.09	A	70 mm ²	0,186

Stranded Aluminium Conductor For Stretch Wire



	Code	Definition	Dia.	Section	Copper Equivalence	Weight (km/kg)
Pure Aluminium	ALO-100.03	Pansy	8,34	42,49 mm ²	26,72	116,4
	ALO-100.04	Popy	9,36	53,48 mm ²	33,63	146,4
	ALO-100.05	Aster	10,5	67,14 mm ²	42,99	184,4
	ALO-100.06	Phlox	11,79	84,91 mm ²	53,4	232,5
Steel Core Aluminium	ALCO-100.02	Sparrow	8,01	39,19 mm ²	21,1	135,7
	ALCO-100.03	Robin	9	49,48 mm ²	26,7	171,4
	ALCO-100.04	Rawen	10,11	62,44 mm ²	33,7	216,2
	ALCO-100.05	Quail	11,34	78,55 mm ²	42,3	272.1
	ALCO-100.06	Pigecon	12,75	99,3 mm ²	53,5	343,9

Stranded Galvanized Steel Conductor For Stretch Wire



Code	Material Coating	Conductor Size	Cross Section	Wire No x Wire Diameter n (Ea.) x Ø(mm)	(Kg/m)
MH-08.06	D2	8 mm	35 mm ²	19 x 1,67	0,285
MH-08.08	D2	9,15 mm	50 mm ²	19 x 1,83	0,395
MH-08.09	D2	11,05 mm	70 mm ²	19 x 2,21	0,580
MH-08.10	D2	12,6 mm	96 mm ²	19 x 2,54	0,760

MAIN MATERIAL
A=Aluminium, B=Copper, D=Iron-Steel,
F=Bronze, G=Gray Cast Iron,
N=Stainless, P=Plastic, S=Brass









COATINGS
1=Electrogalvanizing, 2=Hot Dip Galvanizing, 3=Electrodeposited Copper,
4=Electrodeposited Tin, 5=Electrodeposited Chromium-Nickel,
6=Black Insulation, 7=Yellow-Green Insulation

SCREW NUT
DC=Galvanizing,
NC=Stainless,
SC=Brass

DOWN CONDUCTORS

CONDUCTORS

The down conductor Casing Material and cross-section selection should be made in accordance with the following standards.

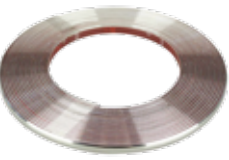
	TS EN 62305 Çizelge 6	TS EN 62561-2	NFC 17-102:2011	
	Bakır	Kalay Kaplı Bakır	Alüminyum	Sıcak daldırılmış galvanizli çelik
Round	50 mm ²	-	50 mm ²	
		-		
	CS-101.08		ALS-08.08	GD-101.08
Tressed	50 mm ² . Her telin çapı en az 1,7mm.			
		-		
	CO-101.08			MH-08.08
Strip	25x2 mm.		25x3	20x2,5
			-	
	CBR-100.08	CBR-100.08.B4		CG.101.08
Coating thickness	-	en az 1 µm.	-	en az 50 µm.

Expansion Piece



Flexible Conductor For Expansion

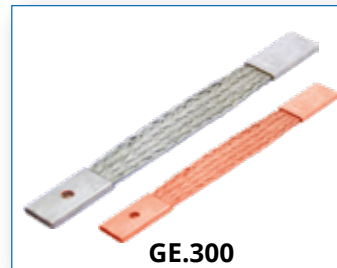

In mesh method applications, seasonal temperature differences cause conductors to lengthen and shorten.

This situation damages the installation. Expansion elements for a healthy and long-lasting installation should be used.

DOWN CONDUCTORS

ISOLATED LIGHTNING PROTECTION

Low Impedance Down Conductor



AT FIRST GLANCE - LICON™

- ✓ Special insulation suitable for lightning current
- ✓ Very low impedance,
- ✓ High strength
- ✓ Longevity
- ✓ Easy to Apply

Cable Cross-Section

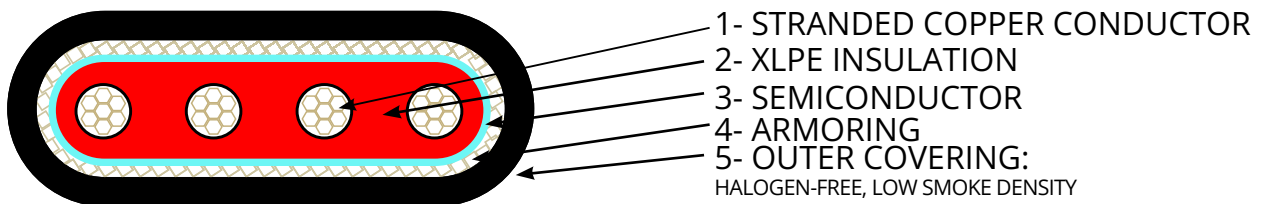

- It is used to minimize the effects of lightning in structures with flammable, explosive and sensitive electronic systems.
- Thanks to its special structure and insulation, it controls the lightning current and does not allow any side-flash effect.
- Thanks to its flat and paintable structure, it prevents visual pollution in buildings.
- Provides ease of installation.

The Advantage of Licon Cable Impedance

50 m	50 mm ² (Ω) Copper Conductor	LICON (Ω)	Advantage over 50 mm ²
Z (50 Hz)	0,03440	0,02940	1,2
Z (100 Hz)	0,06150	0,03250	1,9
Z (500 Hz)	0,29520	0,08560	3,4
Z (1 k Hz)	0,58960	0,16420	3,6
Z (100 k Hz)	58,93620	16,17920	3,6
Z (500 k Hz)	294,68130	80,89600	3,6
Z (1 Mhz)	589,36270	161,79200	3,6
Z (2 Mhz)	1,178,72550	323,58400	3,6

DOWN CONDUCTORS

ISOLATED LIGHTNING PROTECTION

Special Insulated Landing Conductor



- ✓ Special insulation suitable for lightning current
- ✓ High strength
- ✓ Longevity

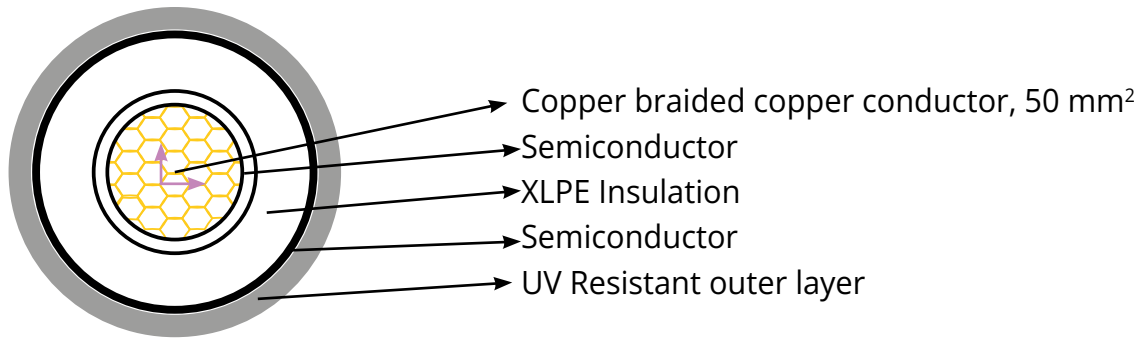

Both conductors were tested with 150 kA according to TS EN 62561.



Copper Bonded Aluminium Conductor



ALS.08.A3

It is used as an alternative to solid copper or solid aluminum conductors as down conductors.

It is used in the area from the catch terminals to the test terminal.

It is not suitable for use in grounding installations.

ADVANTAGES:

- 1. Lightweight:** Lighter than solid copper conductor. Weight: 0.17 kg/m
- 2. Easy to work with:** It is softer than solid copper conductors, making it easier and faster to work with.
- 3. Long-lasting:** The copper coating on the outer surface prevents atmospheric corrosion.
- 4. Economic:** According to Bakır, it is three times lighter and the unit price of the material is much cheaper.

CABLE CONNECTION TERMINALS

REF NO	DESCRIPTION
TKLF.35.01	Tin Plated Copper Terminal, M10
TKLF.35.02	Tin Plated Copper Terminal, 2 X M10
TKLR.50.01	Stainless Steel M10 - Tin Plated Copper Terminal, M10
TKLR.50.02	Tin Plated Copper Terminal, Ø8 mm
TKLF.201.24	Test Clamp, FLF.35 // 2 x 50 mm ²



For FLF.35 Cable

RANK NO	REF NO	DESCRIPTION	BOLT
1	IKFF.113	P+(D1-D2-N-A)	DC-NC
2	IKFF.111	P+(D1-D2-N-A)	DC-NC
3	IKFF.122	P+(D1-D2-N-A)	DC-NC
4	IKFF.109	P+(D1-D2-N-A)	DC-NC
5	IKFF.133	P+(D1-D2-N-A)	DC-NC



For FLF.50 Cable

RANK NO	REF NO	DESCRIPTION	BOLT
1	IKFR.113	P+(D1-D2-N-A)	DC-NC
2	IKFR.111	P+(D1-D2-N-A)	DC-NC
3	IKFR.122	P+(D1-D2-N-A)	DC-NC
4	IKFR.109	P+(D1-D2-N-A)	DC-NC
5	IKFR.133	P+(D1-D2-N-A)	DC-NC



MAIN MATERIAL
 A=Aluminium, B=Copper, D=Iron-Steel,
 F=Bronze, G=Gray Cast Iron,
 N=Stainless, P=Plastic, S=Brass

COATINGS
 1=Electrogalvanizing, 2=Hot Dip Galvanizing, 3=Electrodeposited Copper,
 4=Electrodeposited Tin, 5=Electrodeposited Chromium-Nickel,
 6=Black Insulation, 7=Yellow-Green Insulation

SCREW NUT
 DC=Galvanizing,
 NC=Stainless,
 SC=Brass

INSTALLATION EQUIPMENTS

Single Conductor Clips



Code	Material	Cross-section
IK.101.01	A-B-B4-D1-D2-N	1x16 mm ²
IK.101.02	A-B-B4-D1-D2-N	1x25 mm ²
IK.101.03	A-B-B4-D1-D2-N	1x35 mm ²
IK.101.04	A-B-B4-D1-D2-N	1x50 mm ²
IK.101.05	A-B-B4-D1-D2-N	1x70 mm ²
IK.101.06	A-B-B4-D1-D2-N	1x95 mm ²
IK.101.07	A-B-B4-D1-D2-N	1x120 mm ²
IK.101.08	A-B-B4-D1-D2-N	1x150 mm ²
IK.101.09	A-B-B4-D1-D2-N	1x185 mm ²
IK.101.10	A-B-B4-D1-D2-N	1x240 mm ²



Code	Material	Cross-section
IK.103.01	A-B-B4-D1-D2-N	1x16 mm ²
IK.103.02	A-B-B4-D1-D2-N	1x25 mm ²
IK.103.03	A-B-B4-D1-D2-N	1x35 mm ²
IK.103.04	A-B-B4-D1-D2-N	1x50 mm ²
IK.103.05	A-B-B4-D1-D2-N	1x70 mm ²
IK.103.06	A-B-B4-D1-D2-N	1x95 mm ²
IK.103.07	A-B-B4-D1-D2-N	1x120 mm ²
IK.103.08	A-B-B4-D1-D2-N	1x150 mm ²
IK.103.09	A-B-B4-D1-D2-N	1x185 mm ²
IK.103.10	A-B-B4-D1-D2-N	1x240 mm ²



Code	Material	Cross-section
IK.104.01	A-B-B4-D1-D2-N	1x16 mm ²
IK.104.02	A-B-B4-D1-D2-N	1x25 mm ²
IK.104.03	A-B-B4-D1-D2-N	1x35 mm ²
IK.104.04	A-B-B4-D1-D2-N	1x50 mm ²
IK.104.05	A-B-B4-D1-D2-N	1x70 mm ²
IK.104.06	A-B-B4-D1-D2-N	1x95 mm ²
IK.104.07	A-B-B4-D1-D2-N	1x120 mm ²
IK.104.08	A-B-B4-D1-D2-N	1x150 mm ²
IK.104.09	A-B-B4-D1-D2-N	1x185 mm ²
IK.104.10	A-B-B4-D1-D2-N	1x240 mm ²

MAIN MATERIAL

A=Aluminium, B=Copper, D=Iron-Steel,
F=Bronze, G=Gray Cast Iron,
N=Stainless, P=Plastic, S=Brass

COATINGS

1=Electrogalvanizing, 2=Hot Dip Galvanizing, 3=Electrodeposited Copper,
4=Electrodeposited Tin, 5=Electrodeposited Chromium-Nickel,
6=Black Insulation, 7=Yellow-Green Insulation

SCREW NUT

DC=Galvanizing,
NC=Stainless,
SC=Brass

INSTALLATION EQUIPMENTS

Single Conductor Clips

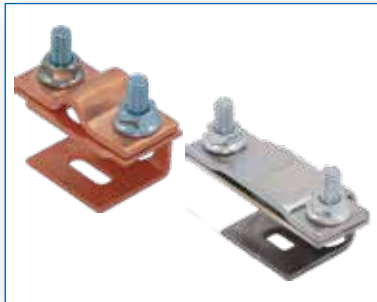

Code	Material	Cross-section	Bolt
IK.109.01	(B+B) (D1+D1) (D2+D2) (N+N)	16mm ²	DC-NC-SC
IK.109.02		25mm ²	DC-NC-SC
IK.109.03		35mm ²	DC-NC-SC
IK.109.04		50mm ²	DC-NC-SC
IK.109.05		70mm ²	DC-NC-SC
IK.109.06		95mm ²	DC-NC-SC
IK.109.07		120mm ²	DC-NC-SC
IK.109.08		150mm ²	DC-NC-SC
IK.109.09		185mm ²	DC-NC-SC
IK.109.10		240mm ²	DC-NC-SC
IK.109.31		20x3mm - 25x5mm	DC-NC-SC
IK.109.32		30x3mm - 30x5mm	DC-NC-SC
IK.109.33		40x3mm - 40x5mm	DC-NC-SC
IK.109.34		50x3mm - 50x5mm	DC-NC-SC



Code	Material	Cross-section	Bolt
IK.102.00	A-B-B4-D1-D2-N	1x10 mm ²	DC-NC
IK.102.01		1x16 mm ²	DC-NC
IK.102.02		1x25 mm ²	DC-NC
IK.102.03		1x35 mm ²	DC-NC
IK.102.04		1x50 mm ²	DC-NC
IK.102.05		1x70 mm ²	DC-NC
IK.102.06		1x95 mm ²	DC-NC
IK.102.07		1x120 mm ²	DC-NC
IK.102.08		1x150 mm ²	DC-NC
IK.102.09		1x185 mm ²	DC-NC
IK.102.10		1x240 mm ²	DC-NC



Code	Material	Cross-section	Bolt
IK.105.31	A-B-B4-D1-D2-N	20x3 - 25x3 mm	DC-NC
IK.105.32		30x3 - 30x5 mm	DC-NC
IK.105.33		40x3 - 40x5 mm	DC-NC
IK.105.34		50x3 - 50x5 mm	DC-NC

INSTALLATION EQUIPMENTS

Conductor Clips



Code	Material	Bolt	Cross-section
IK.107.04	(D1+B)-(D1+D1)-(D2+B) (D2+D2)-(N+B)-(N+N)	DC-NC	1x50 ² mm ²
IK.107.05	(D1+B)-(D1+D1)-(D2+B) (D2+D2)-(N+B)-(N+N)	DC-NC	1x70 ² mm ²
IK.107.06	(D1+B)-(D1+D1)-(D2+B) (D2+D2)-(N+B)-(N+N)	DC-NC	1x95 ² mm ²
IK.107.07	(D1+B)-(D1+D1)-(D2+B) (D2+D2)-(N+B)-(N+N)	DC-NC	1x120 ² mm ²



Code	Material	Bolt	Cross-section
IK.107.24	(D1+B)-(D1+D1)-(D2+B) (D2+D2)-(N+B)-(N+N)	DC-NC	2x50mm ²
IK.107.25	(D1+B)-(D1+D1)-(D2+B) (D2+D2)-(N+B)-(N+N)	DC-NC	2x70mm ²
IK.107.26	(D1+B)-(D1+D1)-(D2+B) (D2+D2)-(N+B)-(N+N)	DC-NC	2x95mm ²
IK.107.27	(D1+B)-(D1+D1)-(D2+B) (D2+D2)-(N+B)-(N+N)	DC-NC	2x120mm ²



Code	Material	Bolt	Cross-section
IK.107.31	(D1+B)-(D1+D1)-(D2+B) (D2+D2)-(N+B)-(N+N)	DC-NC	20x3 - 25x5 mm
IK.107.32	(D1+B)-(D1+D1)-(D2+B) (D2+D2)-(N+B)-(N+N)	DC-NC	30x2 - 30x5 mm
IK.107.33	(D1+B)-(D1+D1)-(D2+B) (D2+D2)-(N+B)-(N+N)	DC-NC	40x3 - 40x5 mm

MAIN MATERIAL

A=Aluminium, B=Copper, D=Iron-Steel,
F=Bronze, G=Gray Cast Iron,
N=Stainless, P=Plastic, S=Brass

COATINGS

1=Electrogalvanizing, 2=Hot Dip Galvanizing, 3=Electrodeposited Copper,
4=Electrodeposited Tin, 5=Electrodeposited Chromium-Nickel,
6=Black Insulation, 7=Yellow-Green Insulation

SCREW NUT

DC=Galvanizing,
NC=Stainless,
SC=Brass

INSTALLATION EQUIPMENTS

Conductor Clips



Code	Material	Bolt	Cross-section
IK.108.04	(B+D1)-(D1+D1)-(B+D2) (D2+D2)-(N+N)	DC-NC	1x50mm ²
IK.108.05	(B+D1)-(D1+D1)-(B+D2) (D2+D2)-(N+N)	DC-NC	1x70mm ²
IK.108.06	(B+D1)-(D1+D1)-(B+D2) (D2+D2)-(N+N)	DC-NC	1x95mm ²
IK.108.07	(B+D1)-(D1+D1)-(B+D2) (D2+D2)-(N+N)	DC-NC	1x120mm ²



Code	Material	Bolt	Cross-section
IK.108.24	(B+D1)-(D1+D1)-(B+D2) (D2+D2)-(N+N)	DC-NC	2x50mm ²
IK.108.25	(B+D1)-(D1+D1)-(B+D2) (D2+D2)-(N+N)	DC-NC	2x70mm ²
IK.108.26	(B+D1)-(D1+D1)-(B+D2) (D2+D2)-(N+N)	DC-NC	2x95mm ²
IK.108.27	(B+D1)-(D1+D1)-(B+D2) (D2+D2)-(N+N)	DC-NC	2x120mm ²



Code	Material	Bolt	Cross-section
IK.108.31	(B+D1)-(D1+D1)-(B+D2) (D2+D2)-(N+N)	DC-NC	20x3-25x5 mm
IK.108.32	(B+D1)-(D1+D1)-(B+D2) (D2+D2)-(N+N)	DC-NC	30x2-30x5 mm
IK.108.33	(B+D1)-(D1+D1)-(B+D2) (D2+D2)-(N+N)	DC-NC	40x3-40x5 mm

MAIN MATERIAL
 A=Aluminium, B=Copper, D=Iron-Steel,
 F=Bronze, G=Gray Cast Iron,
 N=Stainless, P=Plastic, S=Brass

COATINGS
 1=Electrogalvanizing, 2=Hot Dip Galvanizing, 3=Electrodeposited Copper,
 4=Electrodeposited Tin, 5=Electrodeposited Chromium-Nickel,
 6=Black Insulation, 7=Yellow-Green Insulation

SCREW NUT
 DC=Galvanizing,
 NC=Stainless,
 SC=Brass

INSTALLATION EQUIPMENTS

Conductor Clips

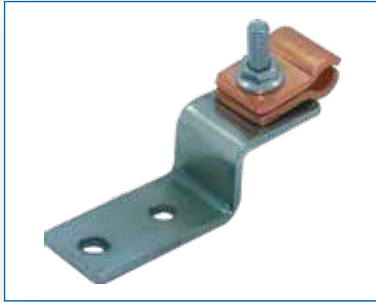

Code	Material	Bolt	Cross-section
IK.111.02	(D1+B)-(D1+D1)-(D2+B) (D2+D2)-(N+B)-(N+N)	DC-NC	1x25mm ²
IK.111.03	(D1+B)-(D1+D1)-(D2+B) (D2+D2)-(N+B)-(N+N)	DC-NC	1x35mm ²
IK.111.04	(D1+B)-(D1+D1)-(D2+B) (D2+D2)-(N+B)-(N+N)	DC-NC	1x50mm ²
IK.111.05	(D1+B)-(D1+D1)-(D2+B) (D2+D2)-(N+B)-(N+N)	DC-NC	1x70mm ²
IK.111.06	(D1+B)-(D1+D1)-(D2+B) (D2+D2)-(N+B)-(N+N)	DC-NC	1x95mm ²
IK.111.07	(D1+B)-(D1+D1)-(D2+B) (D2+D2)-(N+B)-(N+N)	DC-NC	1x120mm ²



Code	Material	Bolt	Cross-section
IK.111.21	(D1+B)-(D1+D1)-(D2+B) (D2+D2)-(N+B)-(N+N)	DC-NC	2x16mm ²
IK.111.24	(D1+B)-(D1+D1)-(D2+B) (D2+D2)-(N+B)-(N+N)	DC-NC	2x50mm ²
IK.111.25	(D1+B)-(D1+D1)-(D2+B) (D2+D2)-(N+B)-(N+N)	DC-NC	2x70mm ²
IK.111.26	(D1+B)-(D1+D1)-(D2+B) (D2+D2)-(N+B)-(N+N)	DC-NC	2x95mm ²



Code	Material	Bolt	Cross-section
IK.111.31	(D1+B)-(D1+D1)-(D2+B) (D2+D2)-(N+B)-(N+N)	DC-NC	20x3-25x5 mm
IK.111.32	(D1+B)-(D1+D1)-(D2+B) (D2+D2)-(N+B)-(N+N)	DC-NC	30x2-30x5 mm
IK.111.33	(D1+B)-(D1+D1)-(D2+B) (D2+D2)-(N+B)-(N+N)	DC-NC	40x3-40x5 mm

MAIN MATERIAL

A=Aluminium, B=Copper, D=Iron-Steel,
F=Bronze, G=Gray Cast Iron,
N=Stainless, P=Plastic, S=Brass

COATINGS

1=Electrogalvanizing, 2=Hot Dip Galvanizing, 3=Electrodeposited Copper,
4=Electrodeposited Tin, 5=Electrodeposited Chromium-Nickel,
6=Black Insulation, 7=Yellow-Green Insulation

SCREW NUT

DC=Galvanizing,
NC=Stainless,
SC=Brass

INSTALLATION EQUIPMENTS

Conductor Clips



Code	Material	Bolt	Cross-section
IK.112.04	(D1+B)-(D1+D1)-(D2+B) (D2+D2)-(N+B)-(N+N)	DC-NC	1x50mm ²
IK.112.05	(D1+B)-(D1+D1)-(D2+B) (D2+D2)-(N+B)-(N+N)	DC-NC	1x70mm ²
IK.112.06	(D1+B)-(D1+D1)-(D2+B) (D2+D2)-(N+B)-(N+N)	DC-NC	1x95mm ²



Code	Material	Bolt	Cross-section
IK.112.24	(D1+B)-(D1+D1)-(D2+B) (D2+D2)-(N+B)-(N+N)	DC-NC	2x50mm ²
IK.112.25	(D1+B)-(D1+D1)-(D2+B) (D2+D2)-(N+B)-(N+N)	DC-NC	2x70mm ²
IK.112.26	(D1+B)-(D1+D1)-(D2+B) (D2+D2)-(N+B)-(N+N)	DC-NC	2x95mm ²



Code	Material	Bolt	Cross-section
IK.112.31	(D1+B)-(D1+D1)-(D2+B) (D2+D2)-(N+B)-(N+N)	DC-NC	20x3-25x3 mm
IK.112.32	(D1+B)-(D1+D1)-(D2+B) (D2+D2)-(N+B)-(N+N)	DC-NC	30x3-30x5 mm
IK.112.33	(D1+B)-(D1+D1)-(D2+B) (D2+D2)-(N+B)-(N+N)	DC-NC	40x3-40x4 mm

MAIN MATERIAL
A=Aluminium, B=Copper, D=Iron-Steel,
F=Bronze, G=Gray Cast Iron,
N=Stainless, P=Plastic, S=Brass

COATINGS
1=Electrogalvanizing, 2=Hot Dip Galvanizing, 3=Electrodeposited Copper,
4=Electrodeposited Tin, 5=Electrodeposited Chromium-Nickel,
6=Black Insulation, 7=Yellow-Green Insulation

SCREW NUT
DC=Galvanizing,
NC=Stainless,
SC=Brass

INSTALLATION EQUIPMENTS

Screw Type Conductor Clips



Code	Material	Bolt	Cross-section
IK.113.02	(D1+B)-(D1+D1)-(D2+B) (D2+D2)-(N+B)-(N+N)	DC-NC	1x25mm ²
IK.113.03	(D1+B)-(D1+D1)-(D2+B) (D2+D2)-(N+B)-(N+N)	DC-NC	1x35mm ²
IK.113.04	(D1+B)-(D1+D1)-(D2+B) (D2+D2)-(N+B)-(N+N)	DC-NC	1x50mm ²
IK.113.05	(D1+B)-(D1+D1)-(D2+B) (D2+D2)-(N+B)-(N+N)	DC-NC	1x70mm ²
IK.113.06	(D1+B)-(D1+D1)-(D2+B) (D2+D2)-(N+B)-(N+N)	DC-NC	1x95mm ²
IK.113.07	(D1+B)-(D1+D1)-(D2+B) (D2+D2)-(N+B)-(N+N)	DC-NC	1x120mm ²



Code	Material	Bolt	Cross-section
IK.113.24	(D1+B)-(D1+D1)-(D2+B) (D2+D2)-(N+B)-(N+N)	DC-NC	2x50mm ²
IK.113.25	(D1+B)-(D1+D1)-(D2+B) (D2+D2)-(N+B)-(N+N)	DC-NC	2x70mm ²
IK.113.26	(D1+B)-(D1+D1)-(D2+B) (D2+D2)-(N+B)-(N+N)	DC-NC	2x95mm ²
IK.113.27	(D1+B)-(D1+D1)-(D2+B) (D2+D2)-(N+B)-(N+N)	DC-NC	2x120mm ²



Kod Code	Casing Material/ Kaplama Material/Coating	Civata Bolt	İletken Kesit Cross Section
IK.113.31	(D1+B)-(D1+D1)-(D2+B) (D2+D2)-(N+B)-(N+N)	DC-NC	20x3-25x5 mm
IK.113.32	(D1+B)-(D1+D1)-(D2+B) (D2+D2)-(N+B)-(N+N)	DC-NC	30x2-30x5 mm
IK.113.33	(D1+B)-(D1+D1)-(D2+B) (D2+D2)-(N+B)-(N+N)	DC-NC	40x3-40x5 mm
IK.113.34	(D1+B)-(D1+D1)-(D2+B) (D2+D2)-(N+B)-(N+N)	DC-NC	50x3-50x5 mm

MAIN MATERIAL

A=Aluminium, B=Copper, D=Iron-Steel,
F=Bronze, G=Gray Cast Iron,
N=Stainless, P=Plastic, S=Brass

COATINGS

1=Electrogalvanizing, 2=Hot Dip Galvanizing, 3=Electrodeposited Copper,
4=Electrodeposited Tin, 5=Electrodeposited Chromium-Nickel,
6=Black Insulation, 7=Yellow-Green Insulation

SCREW NUT

DC=Galvanizing,
NC=Stainless,
SC=Brass

INSTALLATION EQUIPMENTS

Insulated Screw Type Conductor Clips



Code	Material	Bolt	Cross-section
IK.115.04	Special Stainless Alloy	DC-NC	1x50mm ²
IK.115.05		DC-NC	1x70mm ²
IK.115.06		DC-NC	1x95mm ²



Code	Material	Bolt	Cross-section
IK.115.24	Special Stainless Alloy	DC-NC	2x50mm ²
IK.115.25		DC-NC	2x70mm ²
IK.115.26		DC-NC	2x95mm ²



Code	Material	Bolt	Cross-section
IK.115.31	Special Stainless Alloy	DC-NC	20x3 - 25x5 mm
IK.115.32		DC-NC	30x2 - 30x5 mm
IK.115.33		DC-NC	40x3 - 40x5 mm

INSTALLATION EQUIPMENTS

Conductor Clip For Roof Ridges



Code	Material	Bolt	Cross-section
IK.116.04	(D1+B)-(D1+D1)-(D2+B) (D2+D2)-(N+B)-(N+N)	DC-NC	1x50mm ²
IK.116.05	(D1+B)-(D1+D1)-(D2+B) (D2+D2)-(N+B)-(N+N)	DC-NC	1x70mm ²
IK.116.06	(D1+B)-(D1+D1)-(D2+B) (D2+D2)-(N+B)-(N+N)	DC-NC	1x95mm ²
IK.116.07	(D1+B)-(D1+D1)-(D2+B) (D2+D2)-(N+B)-(N+N)	DC-NC	1x120mm ²



Code	Material	Bolt	Cross-section
IK.116.24	(D1+B)-(D1+D1)-(D2+B) (D2+D2)-(N+B)-(N+N)	DC-NC	2x50mm ²
IK.116.25	(D1+B)-(D1+D1)-(D2+B) (D2+D2)-(N+B)-(N+N)	DC-NC	2x70mm ²
IK.116.26	(D1+B)-(D1+D1)-(D2+B) (D2+D2)-(N+B)-(N+N)	DC-NC	2x95mm ²



Code	Material	Bolt	Cross-section
IK.116.31	(D1+B)-(D1+D1)-(D2+B) (D2+D2)-(N+B)-(N+N)	DC-NC	20x3-25x5 mm
IK.116.32	(D1+B)-(D1+D1)-(D2+B) (D2+D2)-(N+B)-(N+N)	DC-NC	30x2-30x5 mm
IK.116.33	(D1+B)-(D1+D1)-(D2+B) (D2+D2)-(N+B)-(N+N)	DC-NC	40x3-40x5 mm

MAIN MATERIAL

A=Aluminium, B=Copper, D=Iron-Steel,
F=Bronze, G=Gray Cast Iron,
N=Stainless, P=Plastic, S=Brass

COATINGS

1=Electrogalvanizing, 2=Hot Dip Galvanizing, 3=Electrodeposited Copper,
4=Electrodeposited Tin, 5=Electrodeposited Chromium-Nickel,
6=Black Insulation, 7=Yellow-Green Insulation

SCREW NUT

DC=Galvanizing,
NC=Stainless,
SC=Brass

INSTALLATION EQUIPMENTS

Conductor Clip For Roof Ridges



Code	Material	Bolt	Cross-section
IK.117.04	(D1+B)-(D1+D1)-(D2+B) (D2+D2)-(N+B)-(N+N)	DC-NC	1x50mm ²
IK.117.05	(D1+B)-(D1+D1)-(D2+B) (D2+D2)-(N+B)-(N+N)	DC-NC	1x70mm ²
IK.117.06	(D1+B)-(D1+D1)-(D2+B) (D2+D2)-(N+B)-(N+N)	DC-NC	1x95mm ²



Code	Material	Bolt	Cross-section
IK.117.24	(D1+B)-(D1+D1)-(D2+B) (D2+D2)-(N+B)-(N+N)	DC-NC	2x50mm ²
IK.117.25	(D1+B)-(D1+D1)-(D2+B) (D2+D2)-(N+B)-(N+N)	DC-NC	2x70mm ²
IK.117.26	(D1+B)-(D1+D1)-(D2+B) (D2+D2)-(N+B)-(N+N)	DC-NC	2x95mm ²



Code	Material	Bolt	Cross-section
IK.117.31	(D1+B)-(D1+D1)-(D2+B) (D2+D2)-(N+B)-(N+N)	DC-NC	20x3-25x5 mm
IK.117.32	(D1+B)-(D1+D1)-(D2+B) (D2+D2)-(N+B)-(N+N)	DC-NC	30x2-30x5 mm
IK.117.33	(D1+B)-(D1+D1)-(D2+B) (D2+D2)-(N+B)-(N+N)	DC-NC	40x3-40x5 mm

MAIN MATERIAL
A=Aluminium, B=Copper, D=Iron-Steel,
F=Bronze, G=Gray Cast Iron,
N=Stainless, P=Plastic, S=Brass

COATINGS
1=Electrogalvanizing, 2=Hot Dip Galvanizing, 3=Electrodeposited Copper,
4=Electrodeposited Tin, 5=Electrodeposited Chromium-Nickel,
6=Black Insulation, 7=Yellow-Green Insulation

SCREW NUT
DC=Galvanizing,
NC=Stainless,
SC=Brass

INSTALLATION EQUIPMENTS

Conductor Clip For Roof Tile



Code	Material	Bolt	Cross-section
IK.118.04	(D1+B)-(D1+D1)-(D2+B) (D2+D2)-(N+B)-(N+N)	DC-NC	1x50mm ²
IK.118.05	(D1+B)-(D1+D1)-(D2+B) (D2+D2)-(N+B)-(N+N)	DC-NC	1x70mm ²
IK.118.06	(D1+B)-(D1+D1)-(D2+B) (D2+D2)-(N+B)-(N+N)	DC-NC	1x95mm ²



Code	Material	Bolt	Cross-section
IK.118.24	(D1+B)-(D1+D1)-(D2+B) (D2+D2)-(N+B)-(N+N)	DC-NC	2x50mm ²
IK.118.25	(D1+B)-(D1+D1)-(D2+B) (D2+D2)-(N+B)-(N+N)	DC-NC	2x70mm ²
IK.118.26	(D1+B)-(D1+D1)-(D2+B) (D2+D2)-(N+B)-(N+N)	DC-NC	2x95mm ²



Code	Material	Bolt	Cross-section
IK.118.31	(D1+B)-(D1+D1)-(D2+B) (D2+D2)-(N+B)-(N+N)	DC-NC	20x3-25x5 mm
IK.118.32	(D1+B)-(D1+D1)-(D2+B) (D2+D2)-(N+B)-(N+N)	DC-NC	30x2-30x5 mm
IK.118.33	(D1+B)-(D1+D1)-(D2+B) (D2+D2)-(N+B)-(N+N)	DC-NC	40x3-40x5 mm

MAIN MATERIAL

A=Aluminium, B=Copper, D=Iron-Steel,
F=Bronze, G=Gray Cast Iron,
N=Stainless, P=Plastic, S=Brass

COATINGS

1=Electrogalvanizing, 2=Hot Dip Galvanizing, 3=Electrodeposited Copper,
4=Electrodeposited Tin, 5=Electrodeposited Chromium-Nickel,
6=Black Insulation, 7=Yellow-Green Insulation

SCREW NUT

DC=Galvanizing,
NC=Stainless,
SC=Brass

INSTALLATION EQUIPMENTS

Conductor Clip For Pylons



Code	Material	Bolt	Cross-section
IK.120.04	(D1+B)-(D1+D1)-(D2+B) (D2+D2)-(N+B)-(N+N)	DC-NC	1x50mm ²
IK.120.05	(D1+B)-(D1+D1)-(D2+B) (D2+D2)-(N+B)-(N+N)	DC-NC	1x70mm ²
IK.120.06	(D1+B)-(D1+D1)-(D2+B) (D2+D2)-(N+B)-(N+N)	DC-NC	1x95mm ²



Code	Material	Bolt	Cross-section
IK.120.24	(D1+B)-(D1+D1)-(D2+B) (D2+D2)-(N+B)-(N+N)	DC-NC	2x50mm ²
IK.120.25	(D1+B)-(D1+D1)-(D2+B) (D2+D2)-(N+B)-(N+N)	DC-NC	2x70mm ²
IK.120.26	(D1+B)-(D1+D1)-(D2+B) (D2+D2)-(N+B)-(N+N)	DC-NC	2x95mm ²



Code	Material	Bolt	Cross-section
IK.120.31	(D1+B)-(D1+D1)-(D2+B) (D2+D2)-(N+B)-(N+N)	DC-NC	20x3-25x5 mm
IK.120.32	(D1+B)-(D1+D1)-(D2+B) (D2+D2)-(N+B)-(N+N)	DC-NC	30x2-30x5 mm
IK.120.33	(D1+B)-(D1+D1)-(D2+B) (D2+D2)-(N+B)-(N+N)	DC-NC	40x3-40x5 mm

MAIN MATERIAL

A=Aluminium, B=Copper, D=Iron-Steel,
F=Bronze, G=Gray Cast Iron,
N=Stainless, P=Plastic, S=Brass

COATINGS

1=Electrogalvanizing, 2=Hot Dip Galvanizing, 3=Electrodeposited Copper,
4=Electrodeposited Tin, 5=Electrodeposited Chromium-Nickel,
6=Black Insulation, 7=Yellow-Green Insulation

SCREW NUT

DC=Galvanizing,
NC=Stainless,
SC=Brass

INSTALLATION EQUIPMENTS

Conductor Clip For Pylons, Long Offset

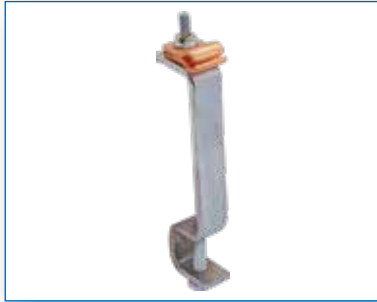

Code	Material	Bolt	Cross-section
IK.121.04	(D1+B)-(D1+D1)-(D2+B) (D2+D2)-(N+B)-(N+N)	DC-NC	1x50mm ²
IK.121.05	(D1+B)-(D1+D1)-(D2+B) (D2+D2)-(N+B)-(N+N)	DC-NC	1x70mm ²
IK.121.06	(D1+B)-(D1+D1)-(D2+B) (D2+D2)-(N+B)-(N+N)	DC-NC	1x95mm ²



Code	Material	Bolt	Cross-section
IK.121.24	(D1+B)-(D1+D1)-(D2+B) (D2+D2)-(N+B)-(N+N)	DC-NC	2x50mm ²
IK.121.25	(D1+B)-(D1+D1)-(D2+B) (D2+D2)-(N+B)-(N+N)	DC-NC	2x70mm ²
IK.121.26	(D1+B)-(D1+D1)-(D2+B) (D2+D2)-(N+B)-(N+N)	DC-NC	2x95mm ²



Code	Material	Bolt	Cross-section
IK.121.31	(D1+B)-(D1+D1)-(D2+B) (D2+D2)-(N+B)-(N+N)	DC-NC	20x3-25x5 mm
IK.121.32	(D1+B)-(D1+D1)-(D2+B) (D2+D2)-(N+B)-(N+N)	DC-NC	30x2-30x5 mm
IK.121.33	(D1+B)-(D1+D1)-(D2+B) (D2+D2)-(N+B)-(N+N)	DC-NC	40x3-40x5 mm

MAIN MATERIAL

A=Aluminium, B=Copper, D=Iron-Steel,
F=Bronze, G=Gray Cast Iron,
N=Stainless, P=Plastic, S=Brass

COATINGS

1=Electrogalvanizing, 2=Hot Dip Galvanizing, 3=Electrodeposited Copper,
4=Electrodeposited Tin, 5=Electrodeposited Chromium-Nickel,
6=Black Insulation, 7=Yellow-Green Insulation

SCREW NUT

DC=Galvanizing,
NC=Stainless,
SC=Brass

INSTALLATION EQUIPMENTS

Conductor Clip For Masts



Code	Material / Coated	Bolt Dia.	Cross-Section	
IK.122.20.04		DC-NC 2	1x50mm ²	
IK.122.20.05		DC-NC 2	1x70mm ²	
IK.122.20.06		DC-NC 2	1x95mm ²	
IK.122.20.24		DC-NC 2	2x50mm ²	
IK.122.20.25		DC-NC 2	2x70mm ²	
IK.122.20.26		DC-NC 2	2x95mm ²	
IK.122.20.31		DC-NC 2	20x3-25x5mm	
IK.122.20.32		DC-NC 2	30x2-30x5mm	
IK.122.20.33		DC-NC 2	40x3-40x5mm	
IK.122.25.04		(D1+B)-(D1+D1)-(D2+B) (D2+D2)-(N+B)-(N+N)	DC-NC 2" ¹ / ₂	1x50mm ²
IK.122.25.05			DC-NC 2" ¹ / ₂	1x70mm ²
IK.122.25.06			DC-NC 2" ¹ / ₂	1x95mm ²
IK.122.25.24	DC-NC 2" ¹ / ₂		2x50mm ²	
IK.122.25.25	DC-NC 2" ¹ / ₂		2x70mm ²	
IK.122.25.26	DC-NC 2" ¹ / ₂		2x95mm ²	
IK.122.25.31	DC-NC 2" ¹ / ₂		20x3-25x5 mm	
IK.122.25.32	DC-NC 2" ¹ / ₂		30x2-30x5mm	
IK.122.25.33	DC-NC 2" ¹ / ₂		40x3-40x5mm	
IK.122.30.04			DC-NC 3"	1x50mm ²
IK.122.30.05			DC-NC 3"	1x70mm ²
IK.122.30.06			DC-NC 3"	1x95mm ²
IK.122.30.24		DC-NC 3"	2x50mm ²	
IK.122.30.25		DC-NC 3"	2x70mm ²	
IK.122.30.26		DC-NC 3"	2x95mm ²	
IK.122.30.31		DC-NC 3"	20x3-25x5mm	
IK.122.30.32		DC-NC 3"	30x2-30x5mm	
IK.122.30.33		DC-NC 3"	40x3-40x5mm	

MAIN MATERIAL

A=Aluminium, B=Copper, D=Iron-Steel, F=Bronze, G=Gray Cast Iron, N=Stainless, P=Plastic, S=Brass

COATINGS

1=Electrogalvanizing, 2=Hot Dip Galvanizing, 3=Electrodeposited Copper, 4=Electrodeposited Tin, 5=Electrodeposited Chromium-Nickel, 6=Black Insulation, 7=Yellow-Green Insulation

SCREW NUT

DC=Galvanizing, NC=Stainless, SC=Brass

INSTALLATION EQUIPMENTS

Conductor Clip For Clamp Roofs



Code	Material/Coating	Bolt	Cross Section
IK.130.04	(D1+B)-(D1+D1)-(D2+B) (D2+D2)-(N+B)-(N+N)	DC-NC	1x50mm ²
IK.130.05	(D1+B)-(D1+D1)-(D2+B) (D2+D2)-(N+B)-(N+N)	DC-NC	1x70mm ²
IK.130.06	(D1+B)-(D1+D1)-(D2+B) (D2+D2)-(N+B)-(N+N)	DC-NC	1x95mm ²



Code	Material/Coating	Bolt	Cross Section
IK.130.24	(D1+B)-(D1+D1)-(D2+B) (D2+D2)-(N+B)-(N+N)	DC-NC	2x50mm ²
IK.130.25	(D1+B)-(D1+D1)-(D2+B) (D2+D2)-(N+B)-(N+N)	DC-NC	2x70mm ²
IK.130.26	(D1+B)-(D1+D1)-(D2+B)- (D2+D2)-(N+B)-(N+N)	DC-NC	2x95mm ²



Code	Material/Coating	Bolt	Cross Section
IK.130.31	(D1+B)-(D1+D1)-(D2+B) (D2+D2)-(N+B)-(N+N)	DC-NC	20x3-25x5 mm
IK.130.32	(D1+B)-(D1+D1)-(D2+B) (D2+D2)-(N+B)-(N+N)	DC-NC	30x2-30x5 mm
IK.130.33	(D1+B)-(D1+D1)-(D2+B) (D2+D2)-(N+B)-(N+N)	DC-NC	40x3-40x5 mm

MAIN MATERIAL

A=Aluminium, B=Copper, D=Iron-Steel,
F=Bronze, G=Gray Cast Iron,
N=Stainless, P=Plastic, S=Brass

COATINGS

1=Electrogalvanizing, 2=Hot Dip Galvanizing, 3=Electrodeposited Copper,
4=Electrodeposited Tin, 5=Electrodeposited Chromium-Nickel,
6=Black Insulation, 7=Yellow-Green Insulation

SCREW NUT

DC=Galvanizing,
NC=Stainless,
SC=Brass

INSTALLATION EQUIPMENTS

Conductor Clip For Clamp Roofs



Code	Material/Coating	Bolt	Cross Section
IK.131.04	(D1+B)-(D1+D1)-(D2+B) (D2+D2)-(N+B)-(N+N)	DC-NC	1x50mm ²
IK.131.05	(D1+B)-(D1+D1)-(D2+B) (D2+D2)-(N+B)-(N+N)	DC-NC	1x70mm ²
IK.131.06	(D1+B)-(D1+D1)-(D2+B) (D2+D2)-(N+B)-(N+N)	DC-NC	1x95mm ²



Code	Material/Coating	Bolt	Cross Section
IK.131.24	(D1+B)-(D1+D1)-(D2+B) (D2+D2)-(N+B)-(N+N)	DC-NC	2x50mm ²
IK.131.25	(D1+B)-(D1+D1)-(D2+B) (D2+D2)-(N+B)-(N+N)	DC-NC	2x70mm ²
IK.131.26	(D1+B)-(D1+D1)-(D2+B) (D2+D2)-(N+B)-(N+N)	DC-NC	2x95mm ²



Code	Material/Coating	Bolt	Cross Section
IK.131.31	(D1+B)-(D1+D1)-(D2+B) (D2+D2)-(N+B)-(N+N)	DC-NC	20x3-25x5 mm
IK.131.32	(D1+B)-(D1+D1)-(D2+B) (D2+D2)-(N+B)-(N+N)	DC-NC	30x2-30x5 mm
IK.131.33	(D1+B)-(D1+D1)-(D2+B) (D2+D2)-(N+B)-(N+N)	DC-NC	40x3-40x5 mm

MAIN MATERIAL
A=Aluminium, B=Copper, D=Iron-Steel,
F=Bronze, G=Gray Cast Iron,
N=Stainless, P=Plastic, S=Brass

COATINGS
1=Electrogalvanizing, 2=Hot Dip Galvanizing, 3=Electrodeposited Copper,
4=Electrodeposited Tin, 5=Electrodeposited Chromium-Nickel,
6=Black Insulation, 7=Yellow-Green Insulation

SCREW NUT
DC=Galvanizing,
NC=Stainless,
SC=Brass

INSTALLATION EQUIPMENTS

Conductor Clip For Gutters



Code	Material/Coating	Bolt	Cross Section
IK.133.04	(D1+B)-(D1+D1)-(D2+B) (D2+D2)-(N+B)-(N+N)	DC-NC	1x50mm ²
IK.133.05	(D1+B)-(D1+D1)-(D2+B) (D2+D2)-(N+B)-(N+N)	DC-NC	1x70mm ²
IK.133.06	(D1+B)-(D1+D1)-(D2+B) (D2+D2)-(N+B)-(N+N)	DC-NC	1x95mm ²



Code	Material/Coating	Bolt	Cross Section
IK.133.24	(D1+B)-(D1+D1)-(D2+B) (D2+D2)-(N+B)-(N+N)	DC-NC	2x50mm ²
IK.133.25	(D1+B)-(D1+D1)-(D2+B) (D2+D2)-(N+B)-(N+N)	DC-NC	2x70mm ²
IK.133.26	(D1+B)-(D1+D1)-(D2+B) (D2+D2)-(N+B)-(N+N)	DC-NC	2x95mm ²



Code	Material/Coating	Bolt	Cross Section
IK.133.31	(D1+B)-(D1+D1)-(D2+B) (D2+D2)-(N+B)-(N+N)	DC-NC	20x3-25x5 mm
IK.133.32	(D1+B)-(D1+D1)-(D2+B) (D2+D2)-(N+B)-(N+N)	DC-NC	30x2-30x5 mm
IK.133.33	(D1+B)-(D1+D1)-(D2+B)- (D2+D2)-(N+B)-(N+N)	DC-NC	40x3-40x5 mm

MAIN MATERIAL

A=Aluminium, B=Copper, D=Iron-Steel,
F=Bronze, G=Gray Cast Iron,
N=Stainless, P=Plastic, S=Brass

COATINGS

1=Electrogalvanizing, 2=Hot Dip Galvanizing, 3=Electrodeposited Copper,
4=Electrodeposited Tin, 5=Electrodeposited Chromium-Nickel,
6=Black Insulation, 7=Yellow-Green Insulation

SCREW NUT

DC=Galvanizing,
NC=Stainless,
SC=Brass

INSTALLATION EQUIPMENTS

Conductor Clip For Metallic Roofs



Code	Material/Coating	Bolt	Cross Section
IK.134.04	(D1+B)-(D1+D1)-(D2+B) (D2+D2)-(N+B)-(N+N)	DC-NC	1x50mm ²
IK.134.05	(D1+B)-(D1+D1)-(D2+B) (D2+D2)-(N+B)-(N+N)	DC-NC	1x70mm ²
IK.134.06	(D1+B)-(D1+D1)-(D2+B) (D2+D2)-(N+B)-(N+N)	DC-NC	1x95mm ²



Code	Material/Coating	Bolt	Cross Section
IK.134.24	(D1+B)-(D1+D1)-(D2+B) (D2+D2)-(N+B)-(N+N)	DC-NC	2x50mm ²
IK.134.25	(D1+B)-(D1+D1)-(D2+B) (D2+D2)-(N+B)-(N+N)	DC-NC	2x70mm ²
IK.134.26	(D1+B)-(D1+D1)-(D2+B) (D2+D2)-(N+B)-(N+N)	DC-NC	2x95mm ²



Code	Material/Coating	Bolt	Cross Section
IK.134.31	(D1+B)-(D1+D1)-(D2+B) (D2+D2)-(N+B)-(N+N)	DC-NC	20x3-25x5 mm
IK.134.32	(D1+B)-(D1+D1)-(D2+B) (D2+D2)-(N+B)-(N+N)	DC-NC	30x2-30x5 mm
IK.134.33	(D1+B)-(D1+D1)-(D2+B) (D2+D2)-(N+B)-(N+N)	DC-NC	40x3-40x5 mm

MAIN MATERIAL
A=Aluminium, B=Copper, D=Iron-Steel,
F=Bronze, G=Gray Cast Iron,
N=Stainless, P=Plastic, S=Brass

COATINGS
1=Electrogalvanizing, 2=Hot Dip Galvanizing, 3=Electrodeposited Copper,
4=Electrodeposited Tin, 5=Electrodeposited Chromium-Nickel,
6=Black Insulation, 7=Yellow-Green Insulation

SCREW NUT
DC=Galvanizing,
NC=Stainless,
SC=Brass

INSTALLATION EQUIPMENTS

Conductor Clip For Metallic Roofs

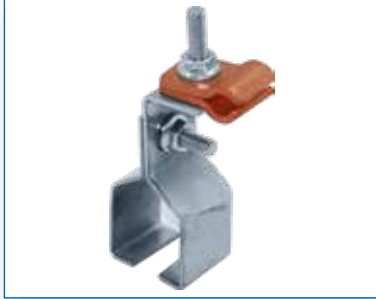

Code	Material/Coating	Bolt	Cross Section
IK.135.04	(D1+B)-(D1+D1)-(D2+B) (D2+D2)-(N+B)-(N+N)	DC-NC	1x50mm ²
IK.135.05	(D1+B)-(D1+D1)-(D2+B) (D2+D2)-(N+B)-(N+N)	DC-NC	1x70mm ²
IK.135.06	(D1+B)-(D1+D1)-(D2+B) (D2+D2)-(N+B)-(N+N)	DC-NC	1x95mm ²



Code	Material/Coating	Bolt	Cross Section
IK.135.24	(D1+B)-(D1+D1)-(D2+B) (D2+D2)-(N+B)-(N+N)	DC-NC	2x50mm ²
IK.135.25	(D1+B)-(D1+D1)-(D2+B) (D2+D2)-(N+B)-(N+N)	DC-NC	2x70mm ²
IK.135.26	(D1+B)-(D1+D1)-(D2+B) (D2+D2)-(N+B)-(N+N)	DC-NC	2x95mm ²



Code	Material/Coating	Bolt	Cross Section
IK.135.31	(D1+B)-(D1+D1)-(D2+B) (D2+D2)-(N+B)-(N+N)	DC-NC	20x3-25x5 mm
IK.135.32	(D1+B)-(D1+D1)-(D2+B) (D2+D2)-(N+B)-(N+N)	DC-NC	30x2-30x5 mm
IK.135.33	(D1+B)-(D1+D1)-(D2+B) (D2+D2)-(N+B)-(N+N)	DC-NC	40x3-40x5 mm

MAIN MATERIAL

A=Aluminium, B=Copper, D=Iron-Steel,
F=Bronze, G=Gray Cast Iron,
N=Stainless, P=Plastic, S=Brass

COATINGS

1=Electrogalvanizing, 2=Hot Dip Galvanizing, 3=Electrodeposited Copper,
4=Electrodeposited Tin, 5=Electrodeposited Chromium-Nickel,
6=Black Insulation, 7=Yellow-Green Insulation

SCREW NUT

DC=Galvanizing,
NC=Stainless,
SC=Brass

INSTALLATION EQUIPMENTS

Plastic Clips



Code	Material/Coating	Cross Section
IPK.206.01	P	6-10 mm



Code	Material/Coating	Cross Section
IPK.207.01	P	6-10 mm



Code	Material/Coating	Diameter	Cross Section
IPK.208.01	P	6-10mm	30x3 mm



Code	Material/Coating	Diameter
IPK.210.01	P	2x8 mm
IPK.210.02	P	2x10 mm

MAIN MATERIAL
 A=Aluminium, B=Copper, D=Iron-Steel,
 F=Bronze, G=Gray Cast Iron,
 N=Stainless, P=Plastic, S=Brass

COATINGS
 1=Electrogalvanizing, 2=Hot Dip Galvanizing, 3=Electrodeposited Copper,
 4=Electrodeposited Tin, 5=Electrodeposited Chromium-Nickel,
 6=Black Insulation, 7=Yellow-Green Insulation

SCREW NUT
 DC=Galvanizing,
 NC=Stainless,
 SC=Brass

INSTALLATION EQUIPMENTS

Plastic Clips



Code	Material/Coating	Diameter
IPK.211.01	P	1x8 mm
IPK.211.02	P	1x10 mm



Code	Material/Coating	Bolt
IPK.201.01	P	M8



Code	Material/Coating	Cross Section
IPK.301.01	P	1x8 mm
IPK.301.02	(P+C)	1x8 mm
IPK.301.03	P	1x10 mm
IPK.301.04	(P+C)	1x10 mm



Code	Material/Coating	Cross Section
IPK.302.01	(IPK-301.03)+1	20x3 mm
IPK.302.02	(IPK-301.03)+2	25x3 mm
IPK.302.03	(IPK-301.03)+3	30x3 mm
IPK.302.04	(IPK-301.03)+4	30x3.5 mm
IPK.302.05	(IPK-301.03)+5	40x4 mm
IPK.302.06	(IPK-301.03)+6	40x5 mm

MAIN MATERIAL

A=Aluminium, B=Copper, D=Iron-Steel,
F=Bronze, G=Gray Cast Iron,
N=Stainless, P=Plastic, S=Brass

COATINGS

1=Electrogalvanizing, 2=Hot Dip Galvanizing, 3=Electrodeposited Copper,
4=Electrodeposited Tin, 5=Electrodeposited Chromium-Nickel,
6=Black Insulation, 7=Yellow-Green Insulation

SCREW NUT

DC=Galvanizing,
NC=Stainless,
SC=Brass

INSTALLATION EQUIPMENTS

Plastic Clips



Code	Material/Coating	Size
IPK.303.00	P	100x100x100 mm
IPK.303.01	P+C	100x100x100 mm



Code	Material/Coating	Cond. Dia	Cross Section
ICK.100.01	P	8 mm	-
ICK.100.02	P+C	10 mm	-
ICK.100.03	P+C	2 mm	2x50mm ²

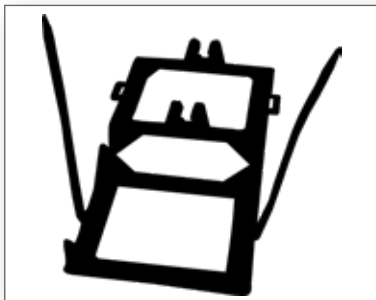

Code	Material/Coating	Size
ICK.103.01	P	8 mm
ICK.103.02	P	10 mm



Code	Material/Coating	Cross Section
ICK.104.01	P+C	1x50 mm ²
ICK.104.02	P+C	1x70 mm ²
ICK.104.31	P+C	25x3 mm
ICK.104.32	P+C	30X3 mm

MAIN MATERIAL
A=Aluminium, B=Copper, D=Iron-Steel,
F=Bronze, G=Gray Cast Iron,
N=Stainless, P=Plastic, S=Brass

COATINGS
1=Electrogalvanizing, 2=Hot Dip Galvanizing, 3=Electrodeposited Copper,
4=Electrodeposited Tin, 5=Electrodeposited Chromium-Nickel,
6=Black Insulation, 7=Yellow-Green Insulation

SCREW NUT
DC=Galvanizing,
NC=Stainless,
SC=Brass

INSTALLATION EQUIPMENTS

Test Clamp

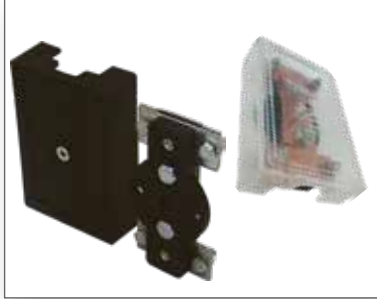

Code	Material/Coating	Bolt	Cross Section
TK.105.04	(P+B)-(P+B4) (P+D1)-(P+D2)-(P+N)	DC-NC	1x50 mm ²
TK.105.05	(P+B)-(P+B4) (P+D1)-(P+D2)-(P+N)	DC-NC	1x70 mm ²
TK.105.24	(P+B)-(P+B4) (P+D1)-(P+D2)-(P+N)	DC-NC	2x50 mm ²
TK.105.25	(P+B)-(P+B4) (P+D1)-(P+D2)-(P+N)	DC-NC	2x70 mm ²
TK.105.32	(P+B)-(P+B4) (P+D1)-(P+D2)-(P+N)	DC-NC	30x3-30x5 mm



Code	Material/Coating	Cross Section
TK.103.04	B-F-S	1x50 mm ²
TK.103.05	B-F-S	1x70 mm ²



Code	Material/Coating	Bolt	Cross Section
TK.104.04	D1-D2-N-S	DC-NC	1x50 mm ²
TK.104.05	D1-D2-N-S	DC-NC	1x70 mm ²
TK.104.06	D1-D2-N-S	DC-NC	1x95 mm ²

MAIN MATERIAL

A=Aluminium, B=Copper, D=Iron-Steel,
F=Bronze, G=Gray Cast Iron,
N=Stainless, P=Plastic, S=Brass

COATINGS

1=Electrogalvanizing, 2=Hot Dip Galvanizing, 3=Electrodeposited Copper,
4=Electrodeposited Tin, 5=Electrodeposited Chromium-Nickel,
6=Black Insulation, 7=Yellow-Green Insulation

SCREW NUT

DC=Galvanizing,
NC=Stainless,
SC=Brass

INSTALLATION EQUIPMENTS

Test Clamp



Code	Material/Coating	Bolt	Cross Section
TK.107.04	D1-D2-N-S	DC-NC	1x50 mm ²
TK.107.05	D1-D2-N-S	DC-NC	1x70 mm ²
TK.107.06	D1-D2-N-S	DC-NC	1x95 mm ²



Code	Material/Coating	Bolt	Cross Section
TK.202.24	(D1+B)-(D1+S)-(D1+F) (D2+S)-(D2+F)-(N+S)-(N+F)	DC-NC	2x50 mm ²
TK.202.25	(D1+B)-(D1+S)-(D1+F) (D2+S)-(D2+F)-(N+S)-(N+F)	DC-NC	2x70 mm ²
TK.202.26	(D1+B)-(D1+S)-(D1+F) (D2+S)-(D2+F)-(N+S)-(N+F)	DC-NC	2x95 mm ²
TK.202.31	(D1+B)-(D1+S)-(D1+F) (D2+S)-(D2+F)-(N+S)-(N+F)	DC-NC	20x3-25x5 mm
TK.202.32	(D1+B)-(D1+S)-(D1+F) (D2+S)-(D2+F)-(N+S)-(N+F)	DC-NC	30x3-30x5 mm
TK.202.33	(D1+B)-(D1+S)-(D1+F) (D2+S)-(D2+F)-(N+S)-(N+F)	DC-NC	40x3-40x5 mm

Protective Tube for Conductor



Code	Material/Coating	Pipe Dia (inch)	Pipe Length
KB.102.01	D1-D2-N	½"	3 m
KB.102.02	D1-D2-N	¾"	3 m
KB.102.03	D1-D2-N	1"	3 m
KB.102.04	D1-D2-N	1" ¼	3 m

INSTALLATION EQUIPMENTS

Clamp For Protective Tube



Code	Material / Coating	Pipe Dia. (inch)
CDM.101.05	D1-D2-N	2"
CDM.101.06	D1-D2-N	2"½
CDM.101.07	D1-D2-N	3"

Equipotential Bonding Piece For Metal Protective Tube



Code	Material/Coating	Pipe Dia
EPT.101.01	A-S-B	¾"
EPT.101.02	A-S-B	1"
EPT.101.03	A-S-B	1" ¼

Equipotential Bonding Piece For Metal Protective Tube



Code	Material/Coating	Pipe Dia
EPT.102.01	A-S-B	¾"
EPT.102.02	A-S-B	1"
EPT.102.03	A-S-B	1" ¼

MAIN MATERIAL

A=Aluminium, B=Copper, D=Iron-Steel, F=Bronze, G=Gray Cast Iron, N=Stainless, P=Plastic, S=Brass

COATINGS

1=Electrogalvanizing, 2=Hot Dip Galvanizing, 3=Electrodeposited Copper, 4=Electrodeposited Tin, 5=Electrodeposited Chromium-Nickel, 6=Black Insulation, 7=Yellow-Green Insulation

SCREW NUT

DC=Galvanizing, NC=Stainless, SC=Brass

A.G. PARAFUDR SERIES



All information in this section is provided for technical information purposes.
Radsan may make changes to the products.
This catalog may not be sufficient, especially for the design of advanced systems.
For technical support and updated information, please contact Radsan (444 62 11).

MAIN MATERIAL

A=Aluminium, B=Copper, D=Iron-Steel,
F=Bronze, G=Gray Cast Iron,
N=Stainless, P=Plastic, S=Brass

COATINGS

1=Electrogalvanizing, 2=Hot Dip Galvanizing, 3=Electrodeposited Copper,
4=Electrodeposited Tin, 5=Electrodeposited Chromium-Nickel,
6=Black Insulation, 7=Yellow-Green Insulation

SCREW NUT

DC=Galvanizing,
NC=Stainless,
SC=Brass

LOCAL DESIGN

DOMESTIC PRODUCTION

SUPERIOR PROTECTION

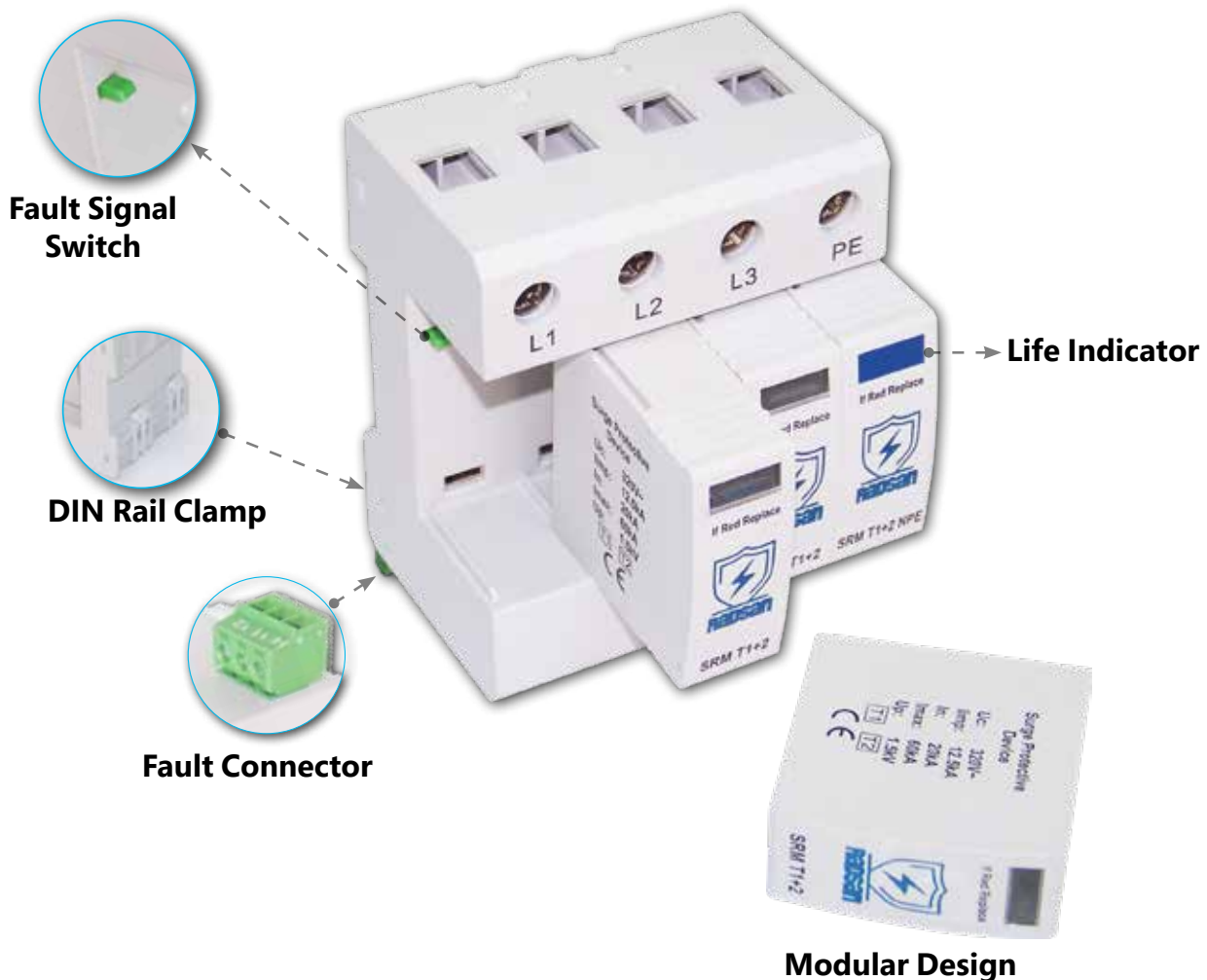

- Modular Design**
- Lifetime Indicator**
- Fault Signal Output**
- Compact Design**
- Space Saving**
- Vibration and Shock Resistance Capacity**
- Easy and Quick Installation**
- Easy Maintenance**
- Compliant with Standards**







LOCAL DESIGN





CERTIFICATES

Domestic Product Certificate

ASO YERLİ MALİ BELGESİ

Belgenin Veriliş Tarihi : 15.10.2021 Belgenin Geçerlilik Tarihi : 15.10.2022 Belge No : 2021107795306
 Çıktısı Çıkmış : RADSAN ELEKTROMEKANİK İNŞAAT ENERJİ MAKİNA TELEKOMÜNİKASYON BİLGİSİM SANAYİ VE TİCARET ANONİM ŞİRKETİ

Şirket Adresi: Hasanoglu Bahçelievler Mahallesi Atatürk Caddesi No:19 ELMADAĞ/ANKARA

Özellikler Vergi Kimlik No: 7340189515 TC Kimlik No: MERSİS No: 0734018951500014

Telefon: 312-8652240 E-posta: radsan@radsan.com.tr
 Faks: 312-8652592 Web Adresi: www.radsan.com.tr

Ticaret Sicil No: 32661 Dye Sicil No: 2391

Ürün Adı: A.G. PARAFUDR TİP 1+2
 Ürün Kodu (PRODCOM/GTIP): 27.12.10.40.00 /
 Teknik Özellikleri(Marka Adı, Modeli, Seri Numarası, Çim):
 Kapasite Raporunun Tarihi : 12.08.2020 No : 25246 Geçerlilik Süresi : 12.08.2022
 Sanayi Sicil Belgesinin Tarihi : 05.12.2012 No : 502463

Yerli Kalkınma Oranı : % 85,28

Özellikler Teknolojik Düzeyi (düşük/orta-düşük/orta-yüksek/yüksek/Parasitiz) : orta-yüksek

Diğer bilgi ve belgeler :

Bu belge Bilim, Sanayi ve Teknoloji Bakanlığı'nun 13.09.2014 tarih ve 29118 sayılı Resmi Gazetede yayımlanan "Yerli Mali Tebliği (SGM 2014/35)" ne istinaden ve TOBB tarafından hazırlanan "Yerli Mali Belgelerin Düzenlenmesi Uygulama Esaslarına" göre 15.10.2021 tarihinde düzenlenmiştir. Belgenin geçerlilik süresi verildiği tarihten itibaren bir yıl geçerlidir.

Düzenleyen Oda/Borsa
ANKARA SANAYİ ODASI





ASO YERLİ MALİ BELGESİ

Belgenin Veriliş Tarihi : 15.10.2021 Belgenin Geçerlilik Tarihi : 15.10.2022 Belge No : 2021107795307
 Çıktısı Çıkmış : RADSAN ELEKTROMEKANİK İNŞAAT ENERJİ MAKİNA TELEKOMÜNİKASYON BİLGİSİM SANAYİ VE TİCARET ANONİM ŞİRKETİ

Şirket Adresi: Hasanoglu Bahçelievler Mahallesi Atatürk Caddesi No:19 ELMADAĞ/ANKARA

Özellikler Vergi Kimlik No: 7340189515 TC Kimlik No: MERSİS No: 0734018951500014

Telefon: 312-8652240 E-posta: radsan@radsan.com.tr
 Faks: 312-8652592 Web Adresi: www.radsan.com.tr

Ticaret Sicil No: 32661 Dye Sicil No: 2391

Ürün Adı: A.G. PARAFUDR TİP 2
 Ürün Kodu (PRODCOM/GTIP): 27.12.10.40.00 /
 Teknik Özellikleri(Marka Adı, Modeli, Seri Numarası, Çim):
 Kapasite Raporunun Tarihi : 12.08.2020 No : 25246 Geçerlilik Süresi : 12.08.2022
 Sanayi Sicil Belgesinin Tarihi : 05.12.2012 No : 502463



Yerli Kalkınma Oranı : % 79,30

Özellikler Teknolojik Düzeyi (düşük/orta-düşük/orta-yüksek/yüksek/Parasitiz) : orta-yüksek

Diğer bilgi ve belgeler :

Bu belge Bilim, Sanayi ve Teknoloji Bakanlığı'nun 13.09.2014 tarih ve 29118 sayılı Resmi Gazetede yayımlanan "Yerli Mali Tebliği (SGM 2014/35)" ne istinaden ve TOBB tarafından hazırlanan "Yerli Mali Belgelerin Düzenlenmesi Uygulama Esaslarına" göre 15.10.2021 tarihinde düzenlenmiştir. Belgenin geçerlilik süresi verildiği tarihten itibaren bir yıl geçerlidir.

Düzenleyen Oda/Borsa
ANKARA SANAYİ ODASI

A.G. Parafudr Certificate EN 61643-11:2012

CERTIFICATE
No. B 107062 0001 Rev. 00

Holder of Certificate: **Radsan Elektromekanik A.Ş.**
1122 cadde 1434 sokak no:1 incek ois, yeminmahalle
06378 Ankara
TURKEY

Production Facility(ies): 080648

Certification Mark: 

Product: **Surge protection equipment (AC SPD)**

Model(s): **SRG T2 1+1, SRG T2 3+1, SRG T2 1P, SRG T2 2P, SRG T2 3P, SRG T2 4P**

Parameters: SPD type: Class II
 Maximum continuous operating voltage Uc: 320VAC
 Max discharge current Imax: 40kA
 Nominal discharge current In: 20kA
 Voltage protection level Up: 1.8kV
 Short circuit withstand Itc: 300A
 Number of ports: One port
 Mounting method: Fixed
 Degree of protection: IP20(after proper installation)
 Temperature range: Extended (-40°C to +70°C)

Tested according to: IEC 61643-11:2011
EN 61643-11:2012

The product was tested on a voluntary basis and complies with the essential requirements. The certification mark shown above can be affixed on the product. It is not permitted to alter the certification mark in any way. In addition the certification holder must not transfer the certificate to third parties. See also notes overleaf.

Test report no.: 041001804570018
Valid until: 2023-11-22

Date: 2020-02-11 (Boris Ouyang)

Page 1 of 1
TUV SUD Product Service GmbH - Certification Body - Rottenstraße 61 - 80339 Munich - Germany



CERTIFICATE
No. B 107062 0003 Rev. 00

Holder of Certificate: **Radsan Elektromekanik A.Ş.**
1122 cadde 1434 sokak no:1 incek ois, yeminmahalle
06378 Ankara
TURKEY

Certification Mark: 

Product: **Surge protection equipment
Surge protective device**

The product was tested on a voluntary basis and complies with the essential requirements. The certification mark shown above can be affixed on the product. It is not permitted to alter the certification mark in any way. In addition the certification holder must not transfer the certificate to third parties. See also notes overleaf.

Test report no.: 701281921401-00
Valid until: 2021-01-15

Date: 2020-02-19 (Jin Zhu)

Page 1 of 2
TUV SUD Product Service GmbH - Certification Body - Rottenstraße 61 - 80339 Munich - Germany



LIFE AND TEMPORARY IMPACTS

Over the past 50 years, rapid advances in technology and developments in electronic systems have significantly increased our daily comfort. Due to the growth of cities, electrical grids have developed and become highly complex. The increasing sensitivity of developing electronic systems and the growing complexity of power supply networks have made electronic systems susceptible to temporary surges. Disruptions in services such as communications, transportation, and healthcare cause significant problems in human life and comfort. Economic consequences are another aspect of the issue. Repair and replacement costs for malfunctioning equipment incur significant expenses. The cost arising from losses such as power outages, data loss, and production system downtime is much higher than the cost of malfunctioning electronic systems.



The need to protect electronic systems against transient surges is constantly increasing. The main reasons for this are:

1. The continuous increase in the use of electronic systems: data centers, computers, servers, etc.
2. Electronic equipment becoming much more sensitive with technological advances
3. The increase in negative factors such as overvoltage, switching, pollution, and noise in large and complex power grids in cities
4. The increase in lightning strikes due to climate change

TRANSIENT SURGES

What are sudden temporary overvoltages (surge voltages)?

Transient overvoltage is a short-term increase in the potential difference (voltage) measured between two or more conductors. In this context, the term "short-term" can range from microseconds (one millionth of a second) to several milliseconds (one thousandth of a second). The increase in voltage can range from a few volts to thousands of volts. For a power supply network, these conductors will be phase, neutral, and ground. For data, communication, and signal lines, these conductors will be lines and ground/shield.

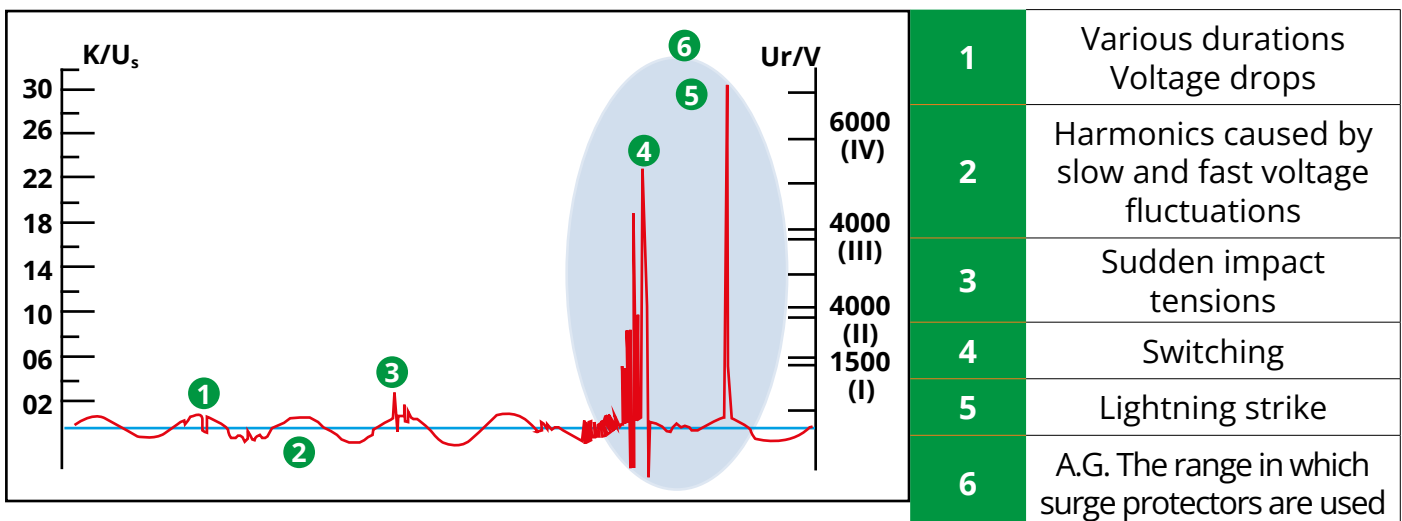

Sources of Transient Overvoltages

Transient overvoltages may occur due to lightning discharges (through resistive, inductive, or capacitive coupling) or as a result of electrical switching operations.

Approximately 35% of all transient overvoltages originate from outside the structure. Typical external sources include lightning, switching operations in the power supply network, electrical faults, and load variations caused by large motors in nearby industrial facilities.

The remaining 65% are generated within buildings and installations, originating from sources such as microwave ovens, laser printers and photocopiers, electric motors, electrical equipment, and even switching devices controlling lighting circuits.

Transient overvoltages caused by lightning and switching phenomena are classified into four distinct categories. Transient overvoltages caused by lightning and switching phenomena are classified into four distinct categories.

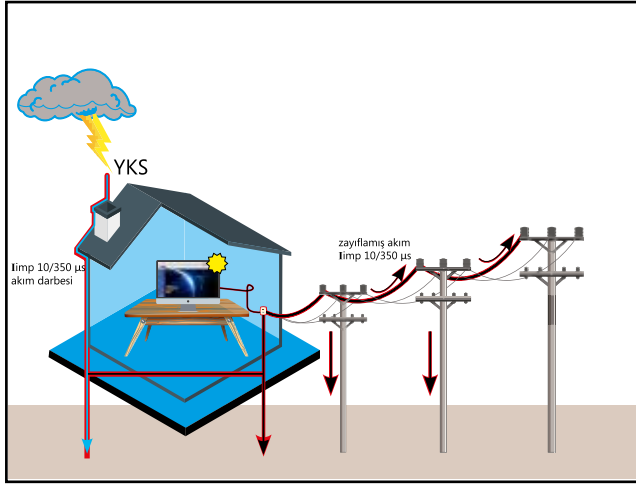

1- Direct Lightning Strike

Lightning is a tremendously powerful, still not fully resolved natural disaster that can reach hundreds of kiloamps, voltage and gigawatts of power. Lightning can cause major damage at the point it falls, but it can also damage an electrical system many kilometers away.

The primary effect of a direct lightning strike is to cause fires in buildings. In buildings equipped with external lightning protection systems, such as lightning rods or cage methods, the risk of fire is greatly reduced. Contrary to popular belief, external lightning protection systems do

not protect electrical systems. The second effect is the damage it causes to electrical systems. In our country's electrical systems, the potential difference between phases and ground is generally 220 V. Neutral and grounding are reference points at 0 volts. When lightning strikes a structure, the current flows to the ground and the electrical grid. Due to the resistance in the PE, the voltage in the PE conductor rises to thousands of volts, creating a large potential difference. This potential difference easily breaks the insulation between the equipment and the grid and ground. Thus, the lightning current flows through the equipment, causing it to malfunction.

2- Havai Hatlara Düşen Yıldırımın Yapıyı Etkilemesi

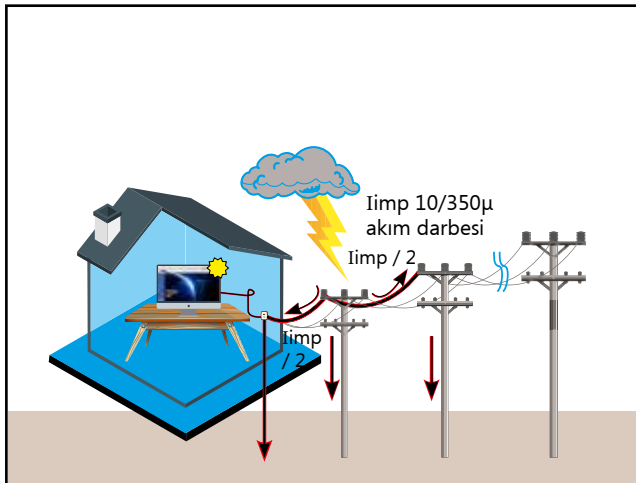

When lightning strikes the lines surrounding the structure and supplying it, the lightning current flows through the line to the structure and causes excessive voltage.

3- Indirect Lightning Strikes (Electromagnetic Effect)

The powerful electromagnetic field of lightning can cause excessive voltage in electrical systems. Similarly, lightning striking an external lightning protection system creates a surge in the closed circuits inside the building. It causes less damage than other sources, but highly sensitive electronic systems such as data lines can be affected by electromagnetic interference.

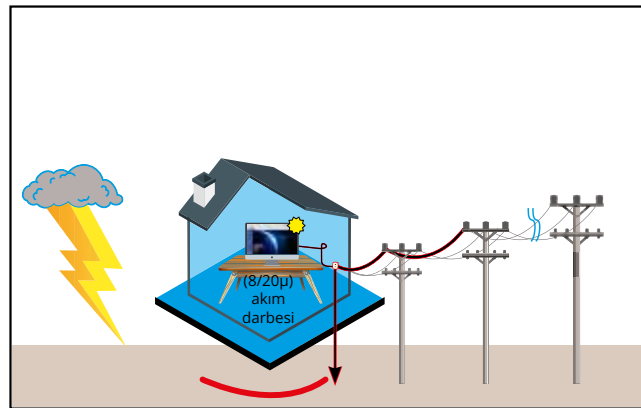
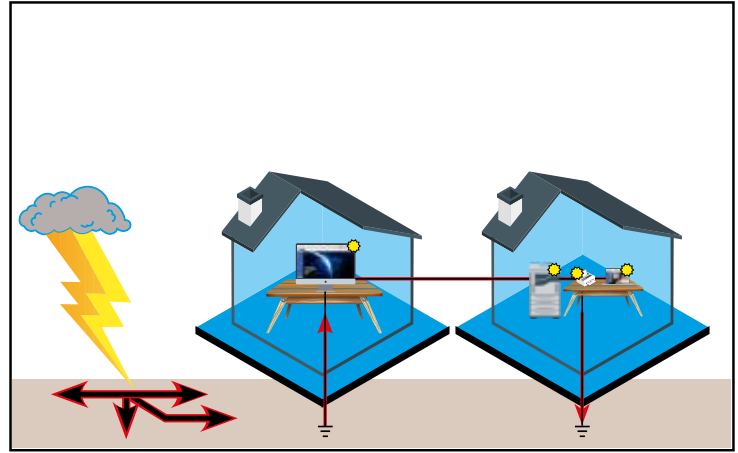
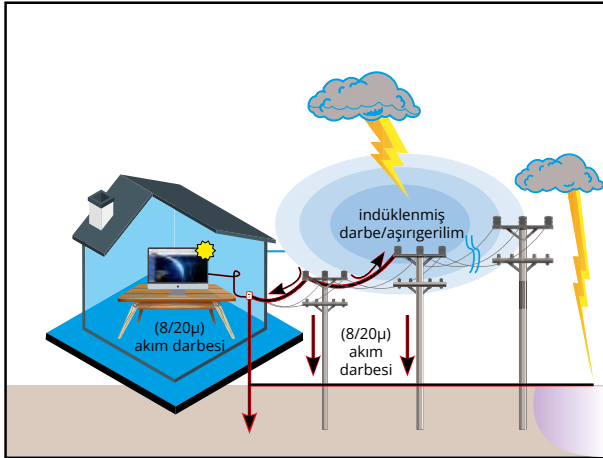

4- Switching

Switching operations occur frequently in almost every location where electrical energy is present. Therefore, transient overvoltages caused by switching events are very common and can be a significant source of interference. Current flowing through a conductor creates a magnetic field in which energy is stored. When the current is interrupted or turned off, the energy in the magnetic field is suddenly released, causing a high voltage transition. Switching equipment such as motors, transformers, arc furnaces, and welding equipment, as well as inductive loads during sudden load changes, cause sudden current changes, resulting in transient voltage surges.

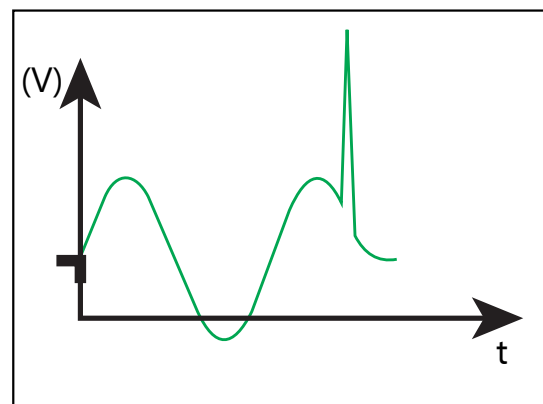
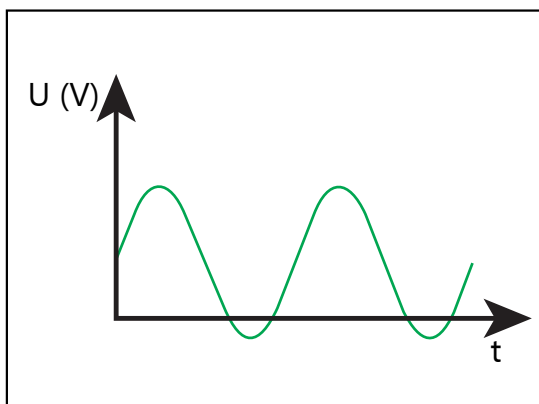

Current Pulses Wave Shapes

Standards such as the IEC EN 61643 series define the characteristics of lightning currents and voltages for testing A.G. surge arresters. These waveforms, determined through years of observation, measurement, and analysis, represent real events most accurately.

Transient waveforms have a rapidly rising edge and a longer tail. They are defined by their peak values, rise time, and decay time.

The following surge waveforms are common current and voltage waveforms used to test surge arresters for use in power, signal, and telecommunication lines.

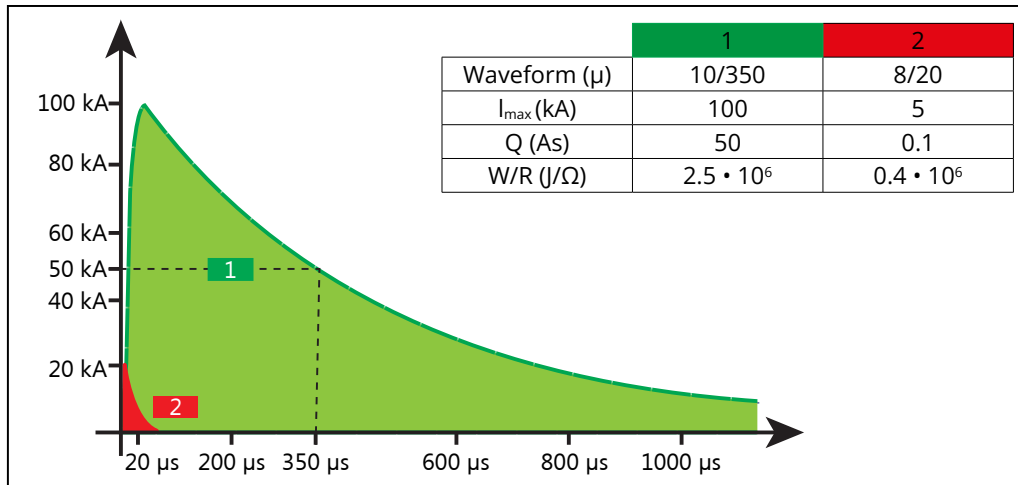

	Ascent time (from 10% to 90% of the highest value)	Peak Current	Half-life
10/350μs wave	10 μs	$I_{imp} = 100$ kA	350μs
8/20μs wave	8 μs	I_n or $I_{max} = 40$ kA	20μs

PRECAUTIONS REQUIRED TO PROTECT FROM TEMPORARY IMPACT

There are several techniques that can be used to minimize the lightning threat to electronic systems. Applying all of them, rather than using them as alternatives, will increase the chance of success.

IEC EN 62305-4 describes a range of measures to minimize the severity of transient overvoltages resulting from lightning and electrical switching:

- Grounding and making equipotential connections
- Electromagnetic shielding and line routing should be done
- Coordinated A.G. surge arrester application
- Improving lightning protection system
- Use of fiber optic cable (with insulation protection)

Protection of equipment against temporary overvoltages relies on the use of A.G. surge arresters and essentially consists of the following:

- Protecting equipment by grounding harmful energy
- Keeping the overvoltage coming to the equipment at a level compatible with the equipment
- Minimizing the effects of induction created by electromagnetic fields resulting from the flow of lightning currents

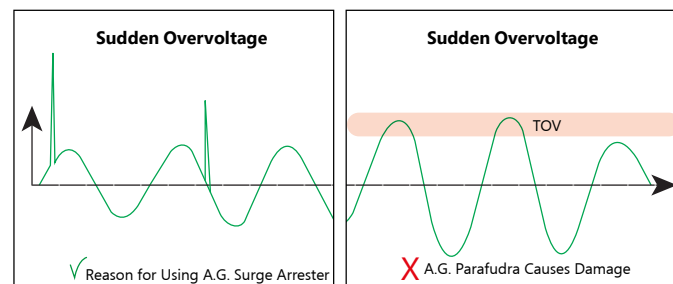

A.G. PARAFUDR HOW IT WORKS

Low voltage surge arresters are specifically designed to protect electrical systems and equipment from transient surges. Using components like varistors and GDTs, they both discharge the load and limit overvoltage to match the surge withstand voltage of the equipment they protect.

The operating principle of the A.G. surge arrester can be compared to that of a circuit breaker:

- In normal use (no overvoltage): Similar to an open circuit breaker. Active lines are isolated from ground.
- When there is an overvoltage, it becomes active by lowering its impedance within a few nanoseconds.

It discharges the lightning current to the ground by working like a closed circuit (circuit breaker closed).

- When the overvoltage is discharged, it automatically returns to its normal impedance (the circuit breaker is open).

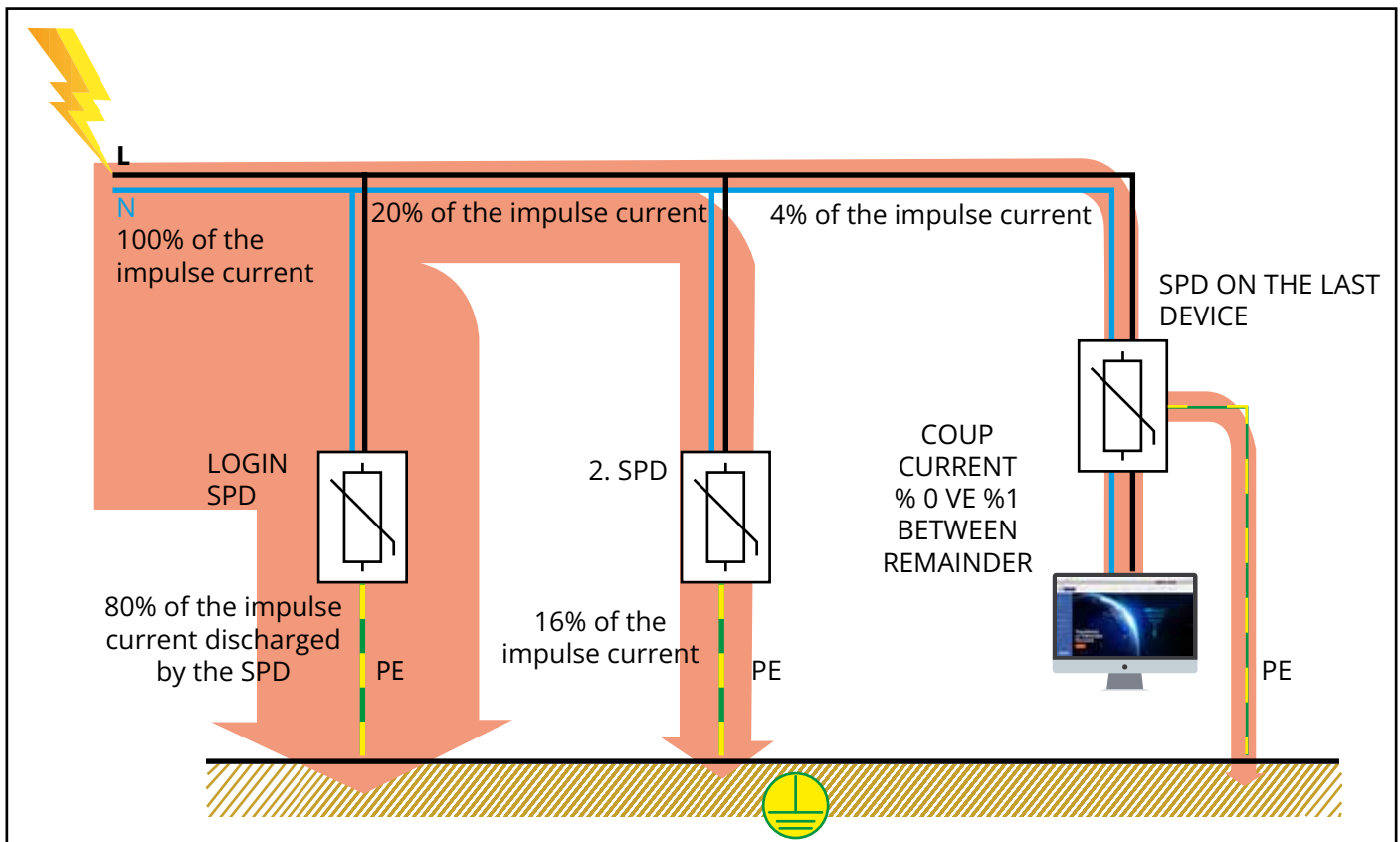
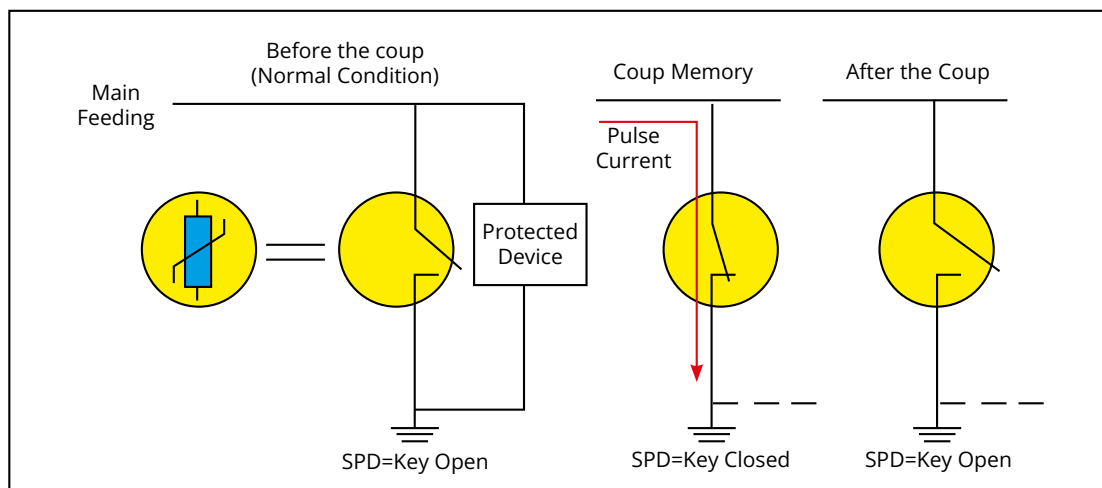

A.G. PARAFUDR VARIETIES

In general, A.G. surge protectors are divided into two classes: low-current power systems and data surge protectors.

For Power Systems A.G. Parafudrlar

1. Type 1 A.G. Surge Arresters are used to protect against direct lightning strikes due to their ability to divert large amounts of energy. They have a high lightning energy discharge capacity. They are tested with a discharge current having a 10/350 μ s waveform.

2. Type 1+2 A.G. Surge protectors are used to protect sensitive equipment at the system's input. They have the ability to divert large amounts of energy directly caused by lightning strikes and the sensitivity to protect electrical equipment directly supplied from the main panel from indirect lightning effects.

3. Type 2 A.G. Surge protectors provide protection against indirect lightning strikes. They protect by providing very fast and high protection against multiple discharges. They should be installed near the equipment to be protected. They are tested with a discharge current having an 8/20 μ s waveform.

Type 3 A.G. Surge Arresters are used to protect sensitive electronic devices. They are tested with a discharge current having a combined waveform (voltage 1.2/50 μ s; current 8/20 μ s).

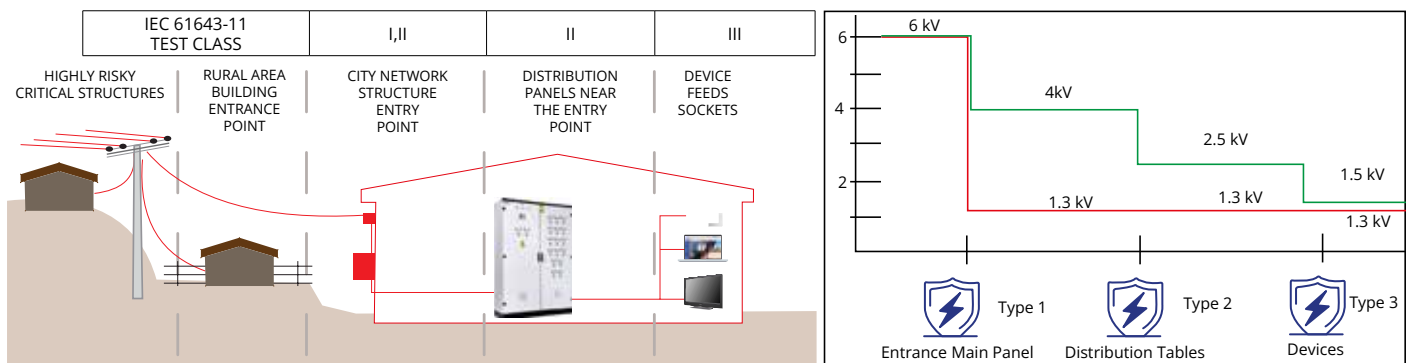

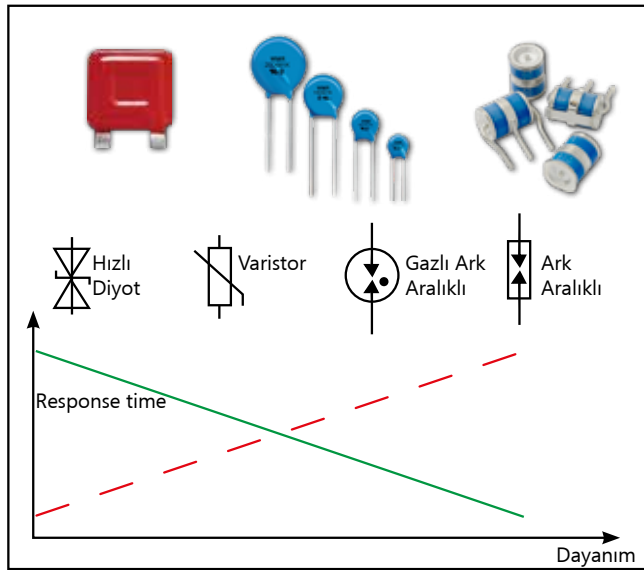

	Type 1	Type 1+2	Type 2	Type 3
Usage Area	To protect against overvoltages caused directly by lightning	For protection against direct and indirect lightning strikes	To protect against indirect lightning overvoltages and impacts caused by switching effects.	To protect sensitive equipment from indirect lightning and switching effects
Structure	Usually spark gaps or GDTs	Generalities varistor+spark gap	Usually varistors or varistor+spark gap	Varistors usually and diodes
Installation Location	The system is inserted into the panel.	It is installed if you have sensitive equipment at the entrance of the system.	It is installed in all electrical panels that supply power to sensitive equipment in the building.	Attached to the panel, end-use point (socket) or equipment.
Tests	10/350 μ s wave in the form with blows	Both 10/350 μ s and 8/20 μ s with pulses in waveform	With 8/20 μ s waveform pulses	voltage 1.2/50 μ s and current 8/20 μ s with pulses in the form of

A.G PARAFUDRDA TECHNOLOGIES USED

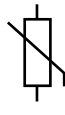
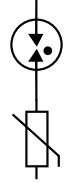
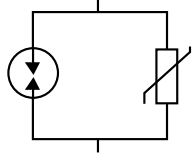
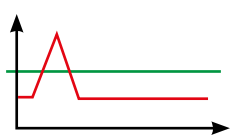
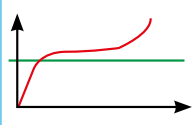
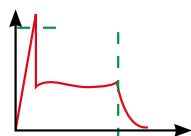
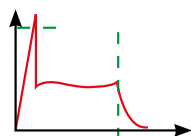

An A.G. surge arrester contains at least one non-linear component. The electrical resistance of this component varies depending on the voltage applied to it. Four types of components are typically used in the Radsan surge arrester group. Since each component has different advantages and disadvantages, combined-hybrid surge arresters have been developed by combining the advantages of both technologies to achieve the best results.

	GAS ARC INTERMITTENT	SPARK GAP	VARISTOR	SERIAL GDT & VARISTOR	PARALLEL GDT & VARISTOR
SYMBOL					
WORK MODE	VOLTAGE SWITCHING	VOLTAGE SWITCHING	VOLTAGE LIMITATION	VOLTAGE SWITCHING AND LIMITING	VOLTAGE SWITCHING AND LIMITING
WORK CURVE					
APPLICATION	TELECOM CORPORATION NETWORK	A.G. ŞEBEKE	A.G. NETWORK	A.G. NETWORK	A.G. NETWORK
PARAFUDR	TYPE 1 or TYPE 2	TYPE 1	TYPE 1 or TYPE 2	TYPE 1+TYPE 2	TYPE 1+TYPE 2

Spark Gap Used In A.G. Parafudrlar

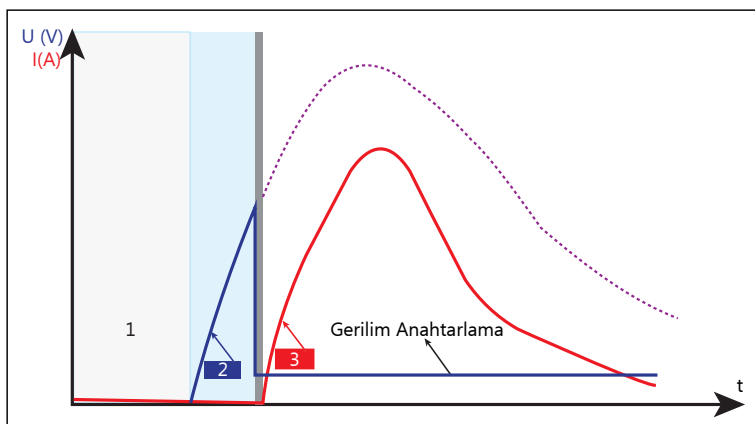

These are switching-class low-voltage surge arresters, designed to protect against high-amplitude surges and operating using the spark gap principle. They can easily withstand strong surges, but due to their somewhat long response times, they cannot protect against low-amplitude, weak surges. They are designed for the first stage of overvoltage protection.

The Spark gap consists of two specially positioned electrodes isolated from the external environment in closed capsules and from each other up to a certain voltage level. (1) Under normal conditions, no current flows between the two

electrodes due to Decoupling. e Spark gap consists of two specially positioned electrodes isolated from the external environment in closed capsules and from each other up to a certain voltage level. (1) Under normal conditions, e Spark gap consists of two specially positioned electrodes isolated from the external environment in closed capsules and from each other up to a certain voltage level. (1) Under normal conditions, no current flows between the two electrodes due to Decoupling. (2) During the pulse, the impedance of the spark gap Decelerates very quickly (100 Dec) to $0.1-1 \Omega$ due to the electric arc formed between the electrodes, and (3) current flows between the electrodes. When the impact ends, the arc is dampened and insulation begins again. The shape, materials and distance between the electrodes characterize the behavior of the arc gap, determining the protection level, discharge capability and other characteristics.

Gas Filled Arc Spaced Protectors (GDT)

They act as high-resistance insulators thanks to their gas-filled, closed capsule and arc. They are typically manufactured as closed capsules with metal electrodes on both sides and a cylindrical ceramic housing. They are typically filled with an inert gas mixture under low pressure. They have a short response time and high discharge damping capacity up to $I_{imp} = 100 \text{ kA}$ (10/350). They have small specific capacitances (very low pF) and high insulation resistances ($>1000 \text{ M}\Omega$). Gas discharge tubes have a long life and high stability.

Varistor Used A.G. Parafudrlar

Its name is derived from the combination of the English words "Variable resistor".

Varistors are voltage-dependent resistors. Because their impedance is controlled by voltage, surge arresters using varistors are called voltage-limiting surge arresters and have high impedance (greater than $1 \text{ M}\Omega$) in the absence of a pulse. These products have low resistance to high-amplitude pulses but a fast response time of ns. They are typically composed of 90% ZnO and 10% additives.

When an overvoltage occurs, the varistor's resistance (impedance) drops very quickly (in a few nanoseconds) to below 1Ω , allowing most of the current to be grounded. Once the surge dissipates, the varistor is isolated again and returns to normal operation.

An important feature of varistors is that a negligible amount of current always flows through them. This current is called leakage current, $I_{PE} = 100-200 \mu\text{A}$.

Silikon Bileşenlere Sahip Koruyucuları (Zener Diyotlar, Tristör, vb.)

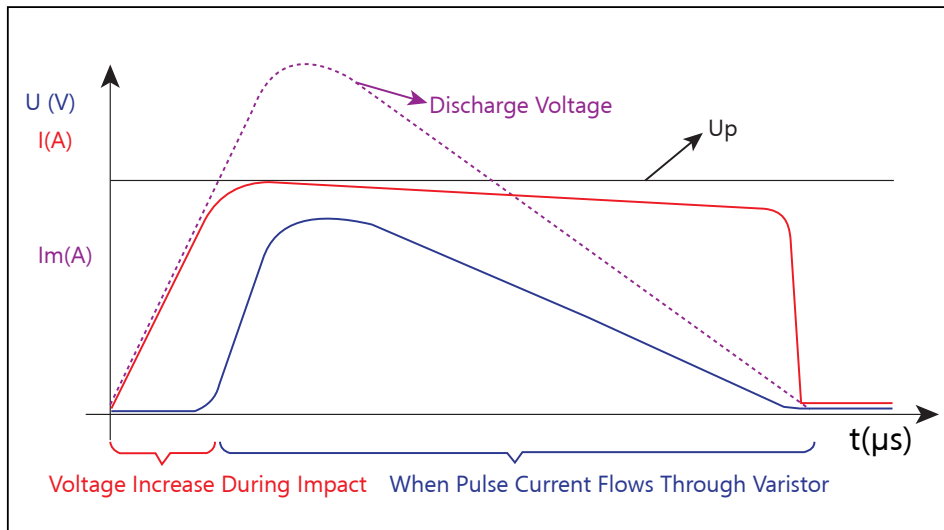

These diodes, thanks to their small size, short response time, and low protection level, are extremely suitable for protecting sensitive electronic circuits in data and telecommunications systems. They are used in low-voltage lines or electronic devices, but their discharge capacity is limited. They provide excellent protection when used in addition to varistor surge suppressors.

Comparison of Spark Gap and Varistors

	Varistor	Spark Gap / GDT	Diode
Power Capacity	It is less powerful than a spark gap. It provides protection against weaker pulses.	It is more powerful than a varistor. It provides protection against stronger surges.	It is less powerful than a varistor.
Reaction Time	Very fast, a few nanoseconds	It is usually slow but can be accelerated with an electronic device.	Very fast, a few nanoseconds
Type of Surge Arrester Used	Typically Type 1+2, Type 2, Type 3	Typically Type 1, Type 1+2, Type 2 neutral	Data surge arresters
Voltage Limiting	Low	High	Low
Service Life	The insulation efficiency constantly decreases. Also, every impact it is exposed to reduces its lifespan.	It has no lifespan. It becomes an open circuit until permanent damage occurs.	There is no service life.

A.G. PARAFUDR THE CHOICE

The correct selection and application of A.G. surge protectors requires first determining the characteristics of the structure or system to be protected. Once the structure to be protected has been defined, the technical specifications of the A.G. surge protectors to be used must be determined.

1- General Principles

- Power surge arresters should be used in power systems and data surge arresters should be used in data systems.

- **Power Systems:** Type 1 surge arresters are preferred in panels that may be affected by direct lightning strikes, Type 2 surge arresters are preferred in panels that may be affected by indirect lightning strikes or switching, and Type 3 surge arresters are preferred in device feeds.

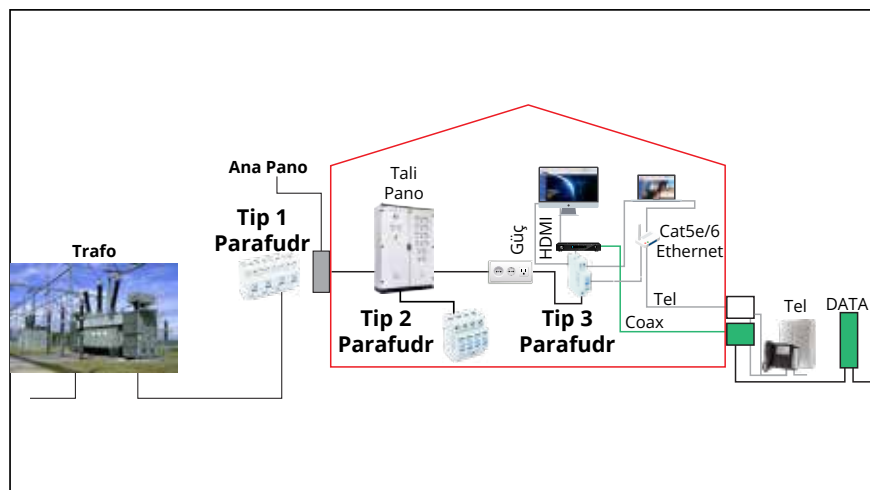

- **Data Systems:** relevant data surge arresters are used for systems such as automation, communication, cameras, sensors, etc.

cameras, sensors, etc.

When protecting a building's electrical system, the first level of protection is achieved by installing a Type 1 class low voltage surge arrester on the main panel at the system entrance. Due to the impact on wiring and the types of surges, additional precautions are necessary. For the second level of protection, Type 2 low voltage surge arresters are used in sub-panels. The third level of protection for sensitive equipment such as computers and TVs is Type 3 low voltage surge

arresters. Type 1+2 surge arresters can be used if a device is powered from the main panel, and Type 2+3 surge arresters can be used if a sensitive device is powered from the sub-panel.

Since data systems, in addition to A.G. power systems, will also be affected by overvoltage, these systems must be protected with appropriate data A.G. surge arresters.

2- Technical Specifications of the Structure to be Protected

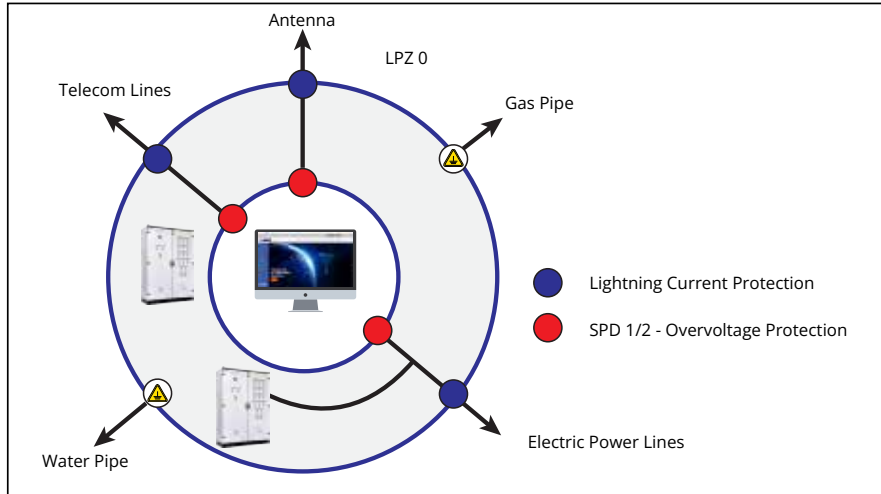

Protection Zones

Surge protection begins at the feed point of the electrical system within the structure and ends at the most sensitive equipment. Discharge energy is reduced by the first stage, with more durable T1 surge arresters, and the second stage,

with more sensitive surge arresters such as T2 and T3. According to standards, the structure is divided into sections based on lightning protection measures, and "Protection Zones" are defined. These sections are determined by measures such as the lightning protection system, armoring, and the use of low voltage surge arresters.

According to the IEC 62305-1 standard, zones are:

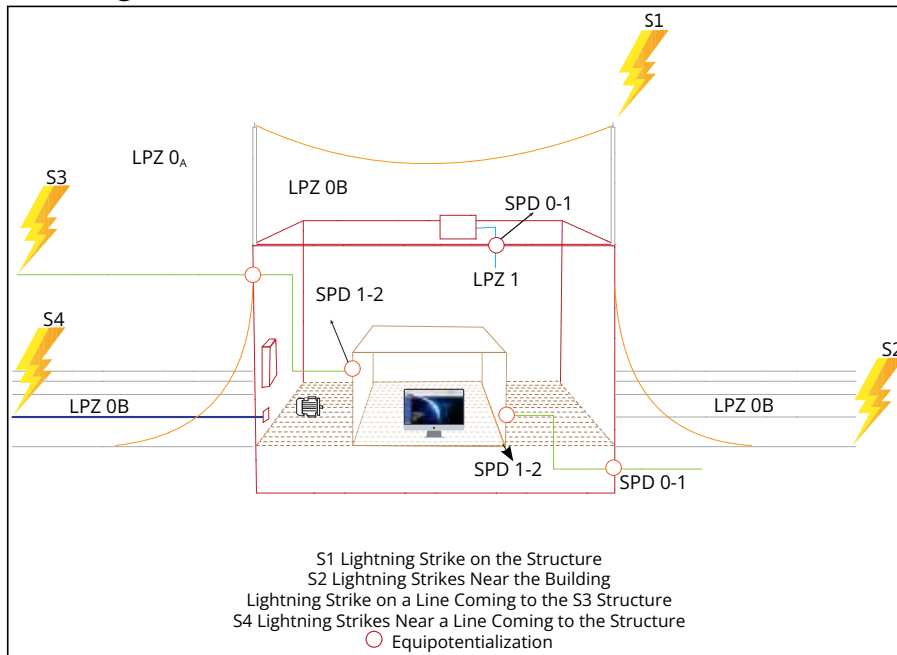







LPZ 0A: This is an open area not protected by an external lightning protection system. Equipment in this area must be exposed to direct lightning strikes and withstand all lightning current and magnetic field effects.

LPZ 0B: This is an open area protected by an external lightning protection system. Equipment in this area is protected against direct lightning strikes but is completely unprotected from magnetic field effects.

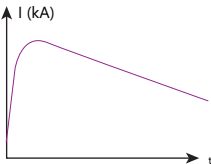
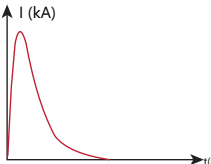
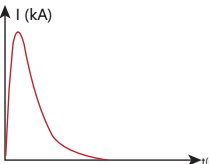
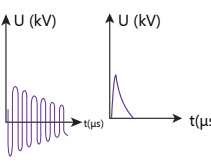
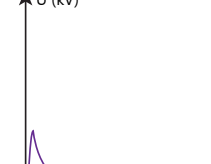
LPZ 1: This is the inner zone where there is no risk of direct lightning strikes and induced currents are less. Cable armoring has been installed in this zone, and a first-level low-voltage surge arrester has been installed.

LPZ 2, LPZ n: more advanced armoring and more sensitive A.G. surge arresters These are different zones where more sensitive protection is provided at each stage, obtained by reducing the induced current using

When determining the protection zones, A.G surge arrester selection can be made according to the table below.

	LPZ 0 _A	LPZ 0 _B	LPZ 1	LPZ 2	LPZ 3
Electromagnetic Field		Normal	Reduced		Very Reduced
Power lines current waveform flowing through	<p>Direct Lightning strike 10/350μs lightning current</p> <p>Electromagnetic field coupling due to direct lightning strike 8/20μs</p> <p>Pulses from the mains 8/20μs</p> 	<p>Electromagnetic field coupling due to direct lightning strike 8/20μs</p> <p>Voltage pulses from the mains 8/20μs</p> 	<p>Electromagnetic field coupling due to direct lightning strike 8/20μs</p> <p>Voltage pulses from the mains 8/20μs</p> 	<p>Reduced effect of the electromagnetic field and voltage surges occurring in the internal network 1.2/50μs voltage surge</p> 	<p>Very low energy voltage surge and electromagnetic field 1.2/50μs voltage surge</p> 
Region to be attached at the entrance A.G. Parafudr		<p>TYPE 1</p> 	<p>TYPE 1+2</p>  <p>TYPE 2</p> 	<p>TYPE 2</p> 	<p>TYPE 3</p> 

3- Types of Electrical Distribution Networks

TN-C-S Network

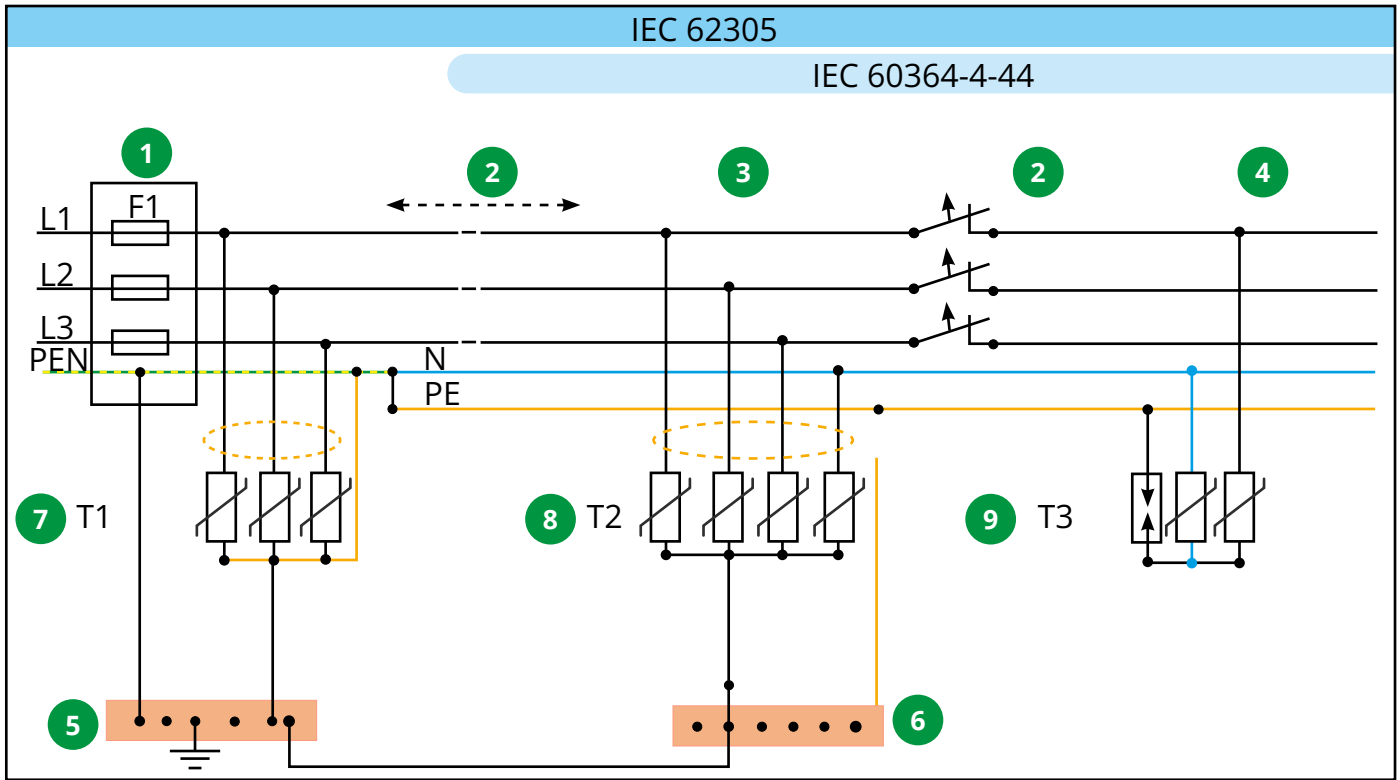

1 Main Panels and Fuses	6 Tali Equipotential Grounding Barası
2 SPD the Cable Length between Dec	7 Type 1 (Class I, SPD) Impact Protector
3 Distribution Table	8 Type 2 (Class II, SPD) Impact Protector
4 The Most End-to Device in the Installation (Last Point)	9 Type 3 (Class III, SPD) Impact Protector
5 Main Grounding Busbar	— Areas Where Pre-Insurance Will Be Applied

In a TN-C network, the electrical installation is fed from the three-phase line (L1, L2, L3) and the combined PEN line.

The use is described in IEC 60364-5-53.

Type 1 lightning arresters are used between phase lines and ground at the power input (main panel).

Type 2 surge arresters are used in distribution panels. With a 3+1 circuit, the phase lines (L1, L2, L3) are connected to the neutral (N) using varistors. The neutral is connected to protective grounding via an arc-gap surge arrester.

Type 3 surge arresters are used in device feeds. Varistors connected to the phase (L) and neutral (N) lines are connected to protective earth (PE) via an arc-gap protector.

TN-S and TT Networks

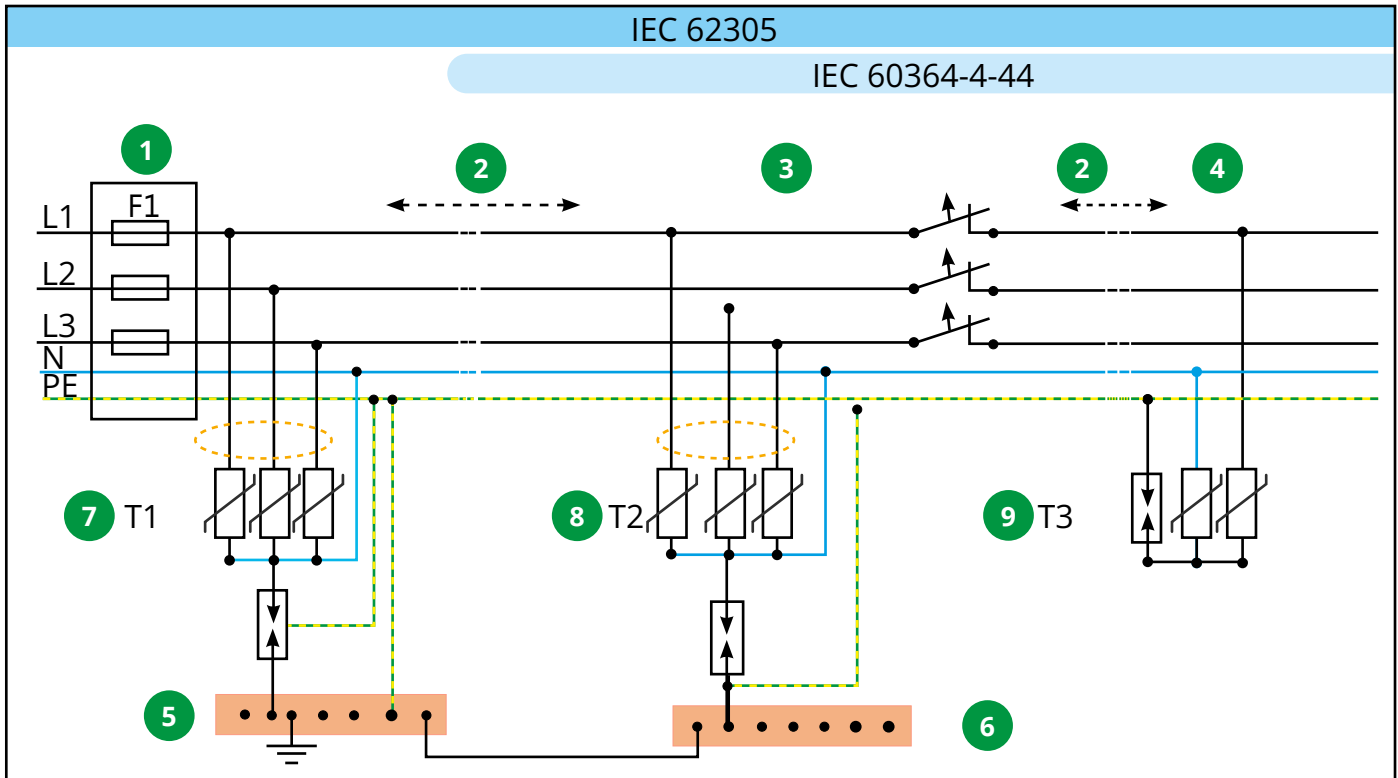

1 Main Panels and Fuses	6 Tali Equipotential Grounding Barası
2 SPD the Cable Length between Dec	7 Type 1 (Class I, SPD) Impact Protector
3 Distribution Table	8 Type 2 (Class II, SPD) Impact Protector
4 The Most End-to Device in the Installation (Last Point)	9 Type 3 (Class III, SPD) Impact Protector
5 Main Grounding Busbar	-- Areas Where Pre-Insurance Will Be Applied

In a TN-S network, the electrical installation is supplied by three phase lines (L1, L2, L3), a neutral cable (N) of the same potential, and an earth cable (PE). However, in a TT network, the electrical unit is supplied by three phase lines (L1, L2, L3), a separately grounded (neutral ground) operating cable (N), and a protective earth cable (PE). The use is described in IEC 61643-11.

Type 1 surge arresters are used at the power input and main switchboard. With a 3+1 circuit, the phase lines (L1, L2, L3) are connected to neutral (N) using varistors or arc-gap surge arresters. The neutral is connected to protective grounding via an arc-gap surge arrester. With the permission of the energy distribution company, surge arresters can also be installed before the main meter.

Type 2 surge arresters are used in distribution panels. With a 3+1 circuit, the phase lines (L1, L2, L3) are connected to the neutral (N) via surge arresters. The neutral is connected to the protective earth via an arc-gap surge arrester.

Type 3 surge arresters are used at device inputs to protect devices against surges. These surges occur primarily between phase (L) and neutral (N). Protected by varistor circuits, the L and N lines are connected to protective earthing via arc-gap surge arresters. This protective circuit between L and N prevents surge currents resulting from transverse voltages directed towards protective earthing (PE).

4- Technical Specifications of Low Voltage Surge Arresters

After determining the protection zones of the building and the type of electrical network, A.G. surge arresters suitable for the technical specifications of the network and the protected equipment should be selected.

1. Continuous Operating Voltage, U_c

The continuous operating voltage of the low voltage surge arrester must be higher than the highest continuous operating voltage of the power system. The lowest recommended U_c values for low voltage surge arresters can be selected according to the table below.

	NETWORK TYPE				
	TT	TN-C	TN-S	IT, Distributed Neutral	IT, Distributed Neutral
Each phase line and neutral	$1,1 \times U_0$	-	$1,1 \times U_0$	$1,1 \times U_0$	-
Each phase line and earth (PE)	$1,1 \times U_0$	-	$1,1 \times U_0$	$\sqrt{3} \times U_0$	Interphase voltage
Neutral and ground (PE)	U_0	-	U_0	U_0	-
Each phase line and PEN	-	$1,1 \times U_0$	-	-	-

U_0 : phase-neutral voltage of the system

2. Transient overvoltage level, U_T

U_T must be greater than the transient overvoltage expected on the System.

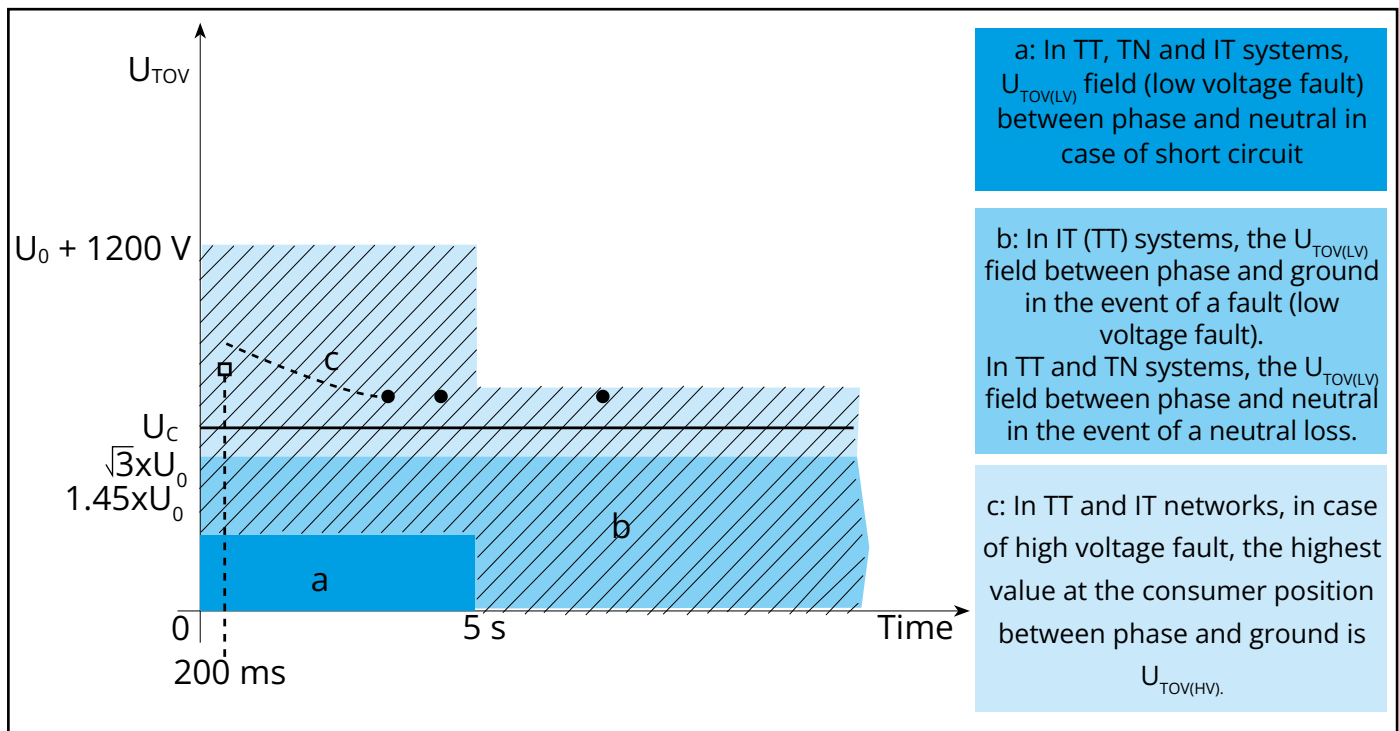

3. In, Iimp

Nominal Discharge Current, I_n , is for Type 2 A.G. surge arresters.

According to the IEC 61643-12 standard, according to the connection below, I_n cannot be less than 20 kA in 8/20 μ s waveform in 3-phase systems and 10 kA in 8/20 μ s single-phase systems.

Lightning Impulse Current, I_{imp} , for Type 1 A.G. surge arresters.

For each protection mode, the current cannot be less than 12.5 kA on a 10/350 μ s waveform. In three-phase systems, it cannot be less than 50 kA on a 10/350 μ s waveform, and in single-phase systems, it cannot be less than 25 kA on a 10/350 μ s waveform.

4. Protection Distance

To determine the location where the L.V. surge arrester will be installed (near the main panel, equipment, etc.), it is necessary to know the acceptable distance between the L.V. surge arrester and the protected equipment.

5. Compatibility of A.G. surge arresters and other devices to be used

The continuous operating current, I_c , should not cause failure in devices such as residual current circuit breakers. I_c should be less than one-third of the residual current $I_{\Delta n}$. It should be noted that residual current circuit breakers, fuses, and circuit breakers installed on the load side will not protect these devices.

6. Voltage protection level, U_p

Every device has an impulse withstand voltage. The U_p value of the L.V. surge arrester must be selected according to the impulse withstand voltage of the equipment to be protected.

7. Additional features

Modular Design: Radsan A.G. surge arresters are designed in two main sections: functional and connection sections that are compatible with each other. The components that provide protection within the modules,

It is installed in the connection section where the DIN rail and cable connections are made.

Life Indicator: Low Voltage Surge Arresters can fail as a result of impacts occurring over many years. Indicators showing the operating status of the Low Voltage Surge Arrester can help determine the condition and determine the need for maintenance.

Fault Warning: In systems with a communication infrastructure, the fault status can be communicated to any user via the dry contact from the LV surge arrester.





***POWER SYSTEMS
and
DATA SYSTEMS***



T1+T2 Class SPD according to EN 61643-11.
Combination: 3+1, TT and TN-S Network

- High level protection is provided by hybrid technology in which varistors and GDT are used together.
- Thanks to its compact design, SPD can be used easily even in the narrowest panels.
- Fault status can be monitored with the indicators on the SPD.
- With the dry contact output, the fault status can be monitored remotely.
- Designed and manufactured in Turkiye.
- 5 years of warranty
- **TUV certificated**



		SRG T1 3P+N 150	SRG T1 3P+N 275	SRG T1 3P+N 385
Electrical Features				
Nominal AC Voltage (50/60Hz)	Un	130V	240V	230V
Max. Continuous Operating Voltage (L-N)	Uc	150V	275V	385V
Nominal discharge current (8/20µs)	In	50 kA (L-N) / 100 kA (N-PE)		
Max. discharge current (8/20µs)	I _{max}	75 kA (L-N) / 160 kA (N-PE)		
Lightning impulse current (10/350µs)	I _{imp}	50 kA (L-N) / 100 kA (N-PE)		
Voltage protection level	Up	≤0,8 kV	≤1,3 kV	≤1,8 kV
Response time	tA	≤25ns / ≤100ns		
Max. backup fuse		315 A gL/gG		
Temporary overvoltage- 120 min. (L-N)	UT	235V	440V	526V
Temporary overvoltage-200 ms (N-PE)	UT	1200V		
Follow current extinguishing capability (N-PE)	I _{fi}	100 A _{RMS}		
Mechanical Features				
Operating temperature range	Ta	-40 C° to +80 C°		
Humidity	RH	5%....%90		
Tightening Torque	M _{max}	4,5 Nm		
Cable Cross-sectional area (max.)		35 mm ² Solid / Stranded / 25 mm ² Fleksible		
For mounting on		35 mm DIN Rail EN 60715		
Casing Material		Thermoplastic, UL 94 V-0		
Degree of protection		IP20		
Specific Features				
Modular		YES		
Fault Indicators		Green for ok / Red for fault		
Remote Fault Signaling		YES		
Thermal Protection		YES		
Warranty		5 years		



CIRCUIT DIAGRAM

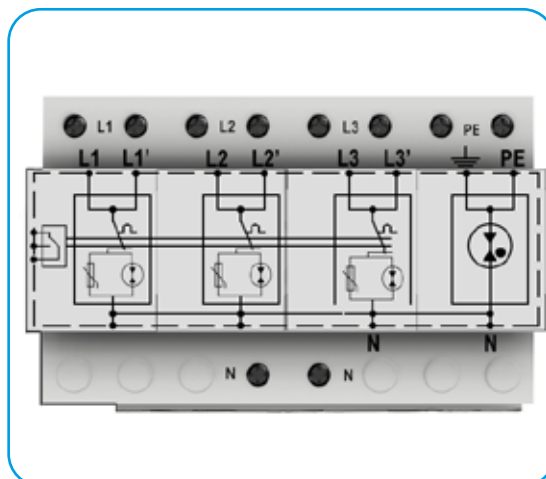

DIMENSIONS

Product Weight	812 gr
Packaged Weight	855 gr
Package Dimensions(ExBxY)	80x150x105 mm

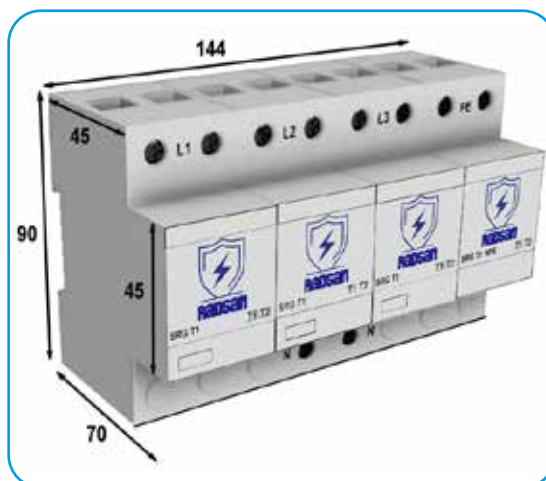

CONNECTION DIAGRAM

Series

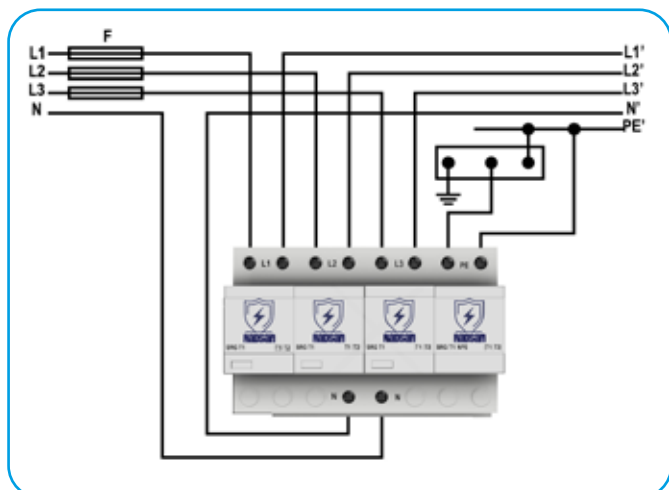

Parallel

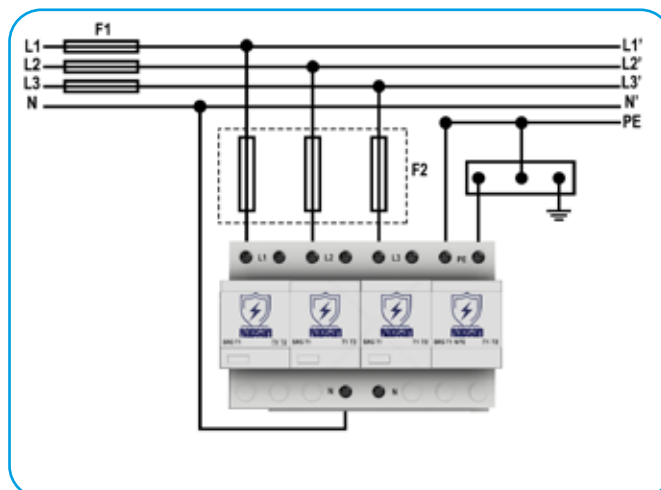



- High level protection is provided by hybrid technology in which varistors and GDT are used together.
- Thanks to its compact design, SPD can be used easily even in the narrowest panels.
- Fault status can be monitored with the indicators on the SPD.
- With the dry contact output, the fault status can be monitored remotely.
- Designed and manufactured in Turkiye.
- 5 years of warranty
- **TUV certificated**



T1+T2 Class SPD according to EN 61643-11.

		SRG T1 1P+N 150	SRG T1 1P+N 275	SRG T1 1P+N 385
Electrical Features				
Nominal AC Voltage (50/60Hz)	Un	130V	240V	230V
Max. Continuous Operating Voltage (L-N)	Uc	150V	275V	385V
Nominal discharge current (8/20µs)	In	50 kA (L-N) / 100 kA (N-PE)		
Max. discharge current (8/20µs)	I _{max}	75 kA (L-N) / 160 kA (N-PE)		
Lightning impulse current (10/350µs)	I _{imp}	50 kA (L-N) / 100 kA (N-PE)		
Voltage protection level	Up	≤0,8 kV	≤1,3 kV	≤1,8 kV
Response time	tA	≤25ns / ≤100ns		
Max. backup fuse		315 A gL/gG		
Geçici Aşırı Gerilim 120 dak. (L-N)	UT	235V	440V	526V
Temporary overvoltage-200 ms (N-PE)	UT	1200V		
Follow current extinguishing capability (N-PE)	I _{fi}	100 A _{RMS}		
Mechanical Features				
Operating temperature range	Ta	-40 C° to +80 C°		
Humidity	RH	5%....%90		
Tightening Torque	M _{max}	4,5 Nm		
Cable Cross-sectional area (max.)		35 mm ² Solid / Stranded / 25 mm ² Flexible		
For mounting on		35 mm DIN Rail EN 60715		
Casing Material		Thermoplastic, UL 94 V-0		
Degree of protection		IP20		
Specific Features				
Modular		YES		
Fault Indicators		Green for ok / Red for fault		
Remote Fault Signaling		YES		
Thermal Protection		YES		
Warranty		5 YEARS		



CIRCUIT DIAGRAM

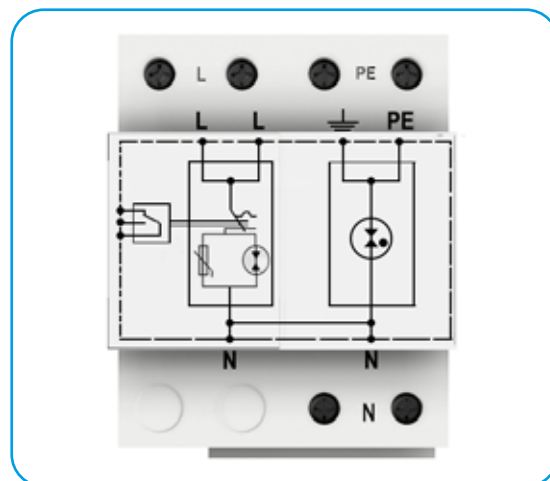

DIMENSIONS

Product Weight	435 gr
Packaged Weight	460 gr
Paket DIMENSIONSİ (ExBxY) (ExBxY)(ExBxY)	80x75x105 mm.

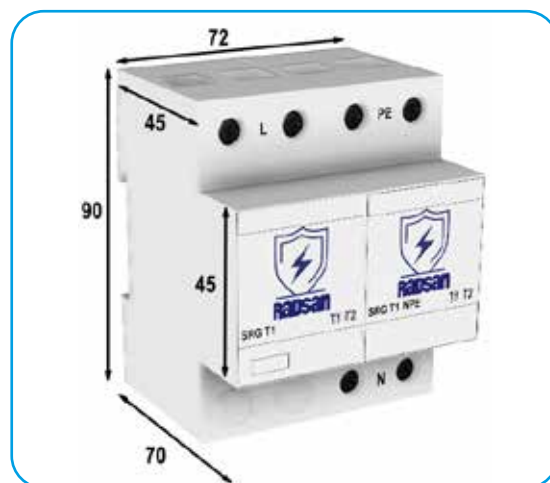

CONNECTION DIAGRAM

Series

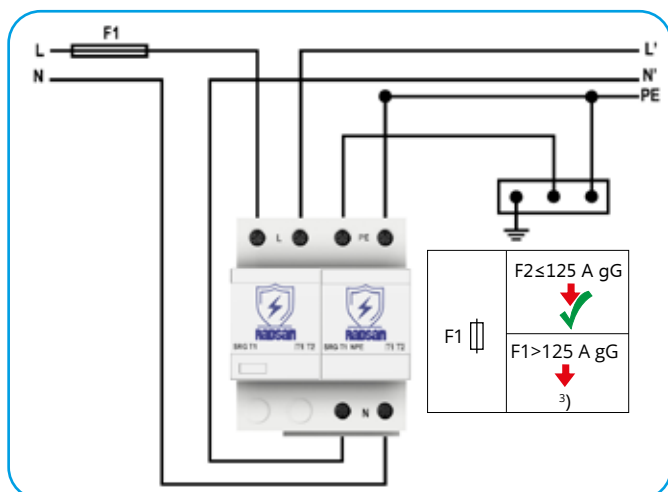

Parallel

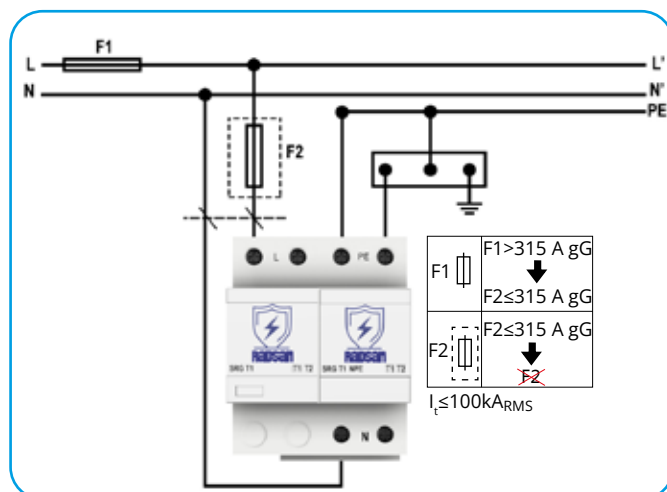



- High level protection is provided by hybrid technology in which varistors and GDT are used together.
- Thanks to its compact design, SPD can be used easily even in the narrowest panels.
- Fault status can be monitored with the indicators on the SPD.
- With the dry contact output, the fault status can be monitored remotely.
- Designed and manufactured in Turkiye.
- 5 years of warranty
- **TUV certificated**



T1+T2 Class SPD according to EN 61643-11.

		SRG T1 4P 150	SRG T1 4P 275	SRG T1 4P 385
Electrical Features				
Nominal AC Voltage (50/60Hz)	Un	130V	240V	230V
Max. Continuous Operating Voltage (L-N)	Uc	150V	275V	385V
Nominal discharge current (8/20µs)	In	50 kA		
Max. discharge current (8/20µs)	I _{max}	160 kA		
Lightning impulse current (10/350µs)	I _{imp}	50 kA		
Voltage protection level	Up	≤0,8 kV	≤1,3 kV	≤1,5 kV
Response time	tA	≤25ns / ≤100ns		
Max. backup fuse		315 A gL/gG		
Temporary overvoltage- 120 min. (L-N)	UT	235V	440V	526V
Temporary overvoltage-200 ms (N-PE)	UT	1200V		
Follow current extinguishing capability (N-PE)	I _{fi}	100 A _{RMS}		
Mechanical Features				
Operating temperature range	Ta	-40 C° to +80 C°		
Humidity	RH	5%...%90		
Tightening Torque	M _{max}	4,5 Nm		
Cable Cross-sectional area (max.)		35 mm ² Solid / Stranded / 25 mm ² Flexible		
For mounting on		35 mm DIN Rail EN 60715		
Casing Material		Thermoplastic, UL 94 V-0		
Degree of protection		IP20		
Specific Features				
Modular		YES		
Fault Indicators		Green for ok / Red for fault		
Remote Fault Signaling		YES		
Thermal Protection		YES		
Warranty		5 YEARS		



CIRCUIT DIAGRAM

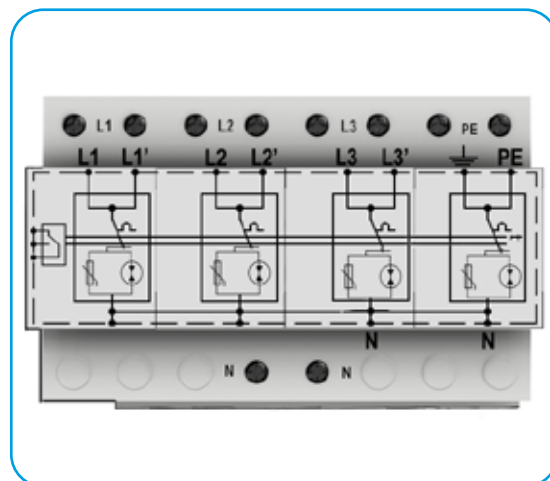

DIMENSIONS

Product Weight:	812 gr.
Packaged Weight:	855 gr.
Package Dimensions (ExBxY)	80x150x105 mm.

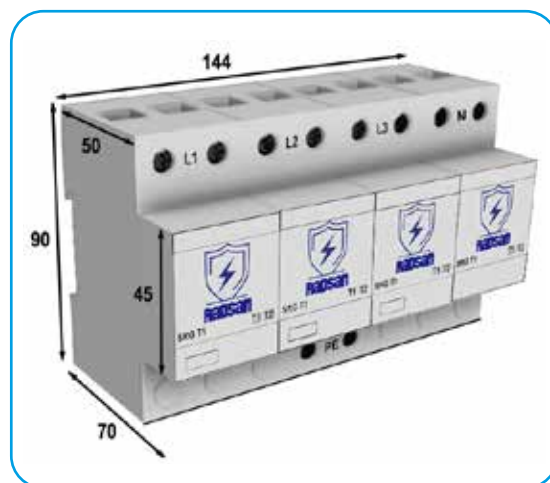

CONNECTION DIAGRAM

Series

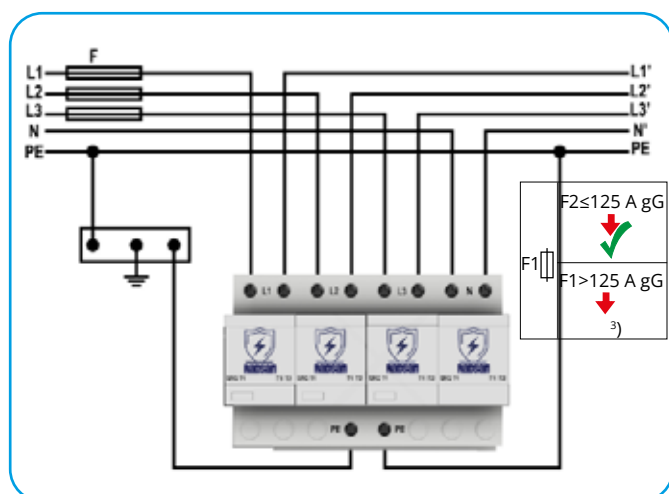

Parallel

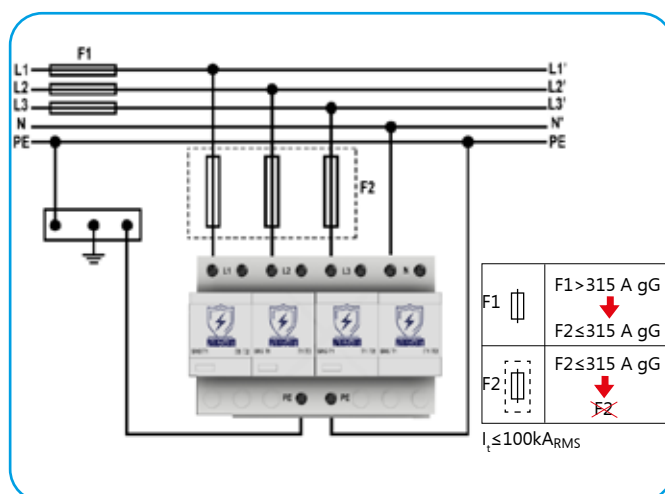



- High level protection is provided by hybrid technology in which varistors and GDT are used together.
- Thanks to its compact design, SPD can be used easily even in the narrowest panels.
- Fault status can be monitored with the indicators on the SPD.
- With the dry contact output, the fault status can be monitored remotely.
- Designed and manufactured in Turkiye.
- 5 years of warranty
- **TUV certificated**



T1+T2 Class SPD according to EN 61643-11.

SRG T1 3P 150

SRG T1 3P 275

SRG T1 3P 385

Electrical Features				
Nominal AC Voltage (50/60Hz)	Un	130V	240V	230V
Max. Continuous Operating Voltage (L-N)	Uc	150V	275V	385V
Nominal discharge current (8/20µs)	In		50 kA	
Max. discharge current (8/20µs)	I _{max}		160 kA	
Lightning impulse current (10/350µs)	I _{imp}		50 kA	
Voltage protection level	Up	≤0,8 kV	≤1,3 kV	≤1,5 kV
Response time	t _A		≤25ns / ≤100ns	
Max. backup fuse			315 A gL/gG	
Temporary overvoltage- 120 min. (L-N)	UT	235V	440V	526V
Temporary overvoltage-200 ms (N-PE)	UT		1200V	
Follow current extinguishing capability (N-PE)	I _{fi}		100 A _{RMS}	

Mechanical Features				
Operating temperature range	T _a		-40 C° to +80 C°	
Humidity	RH		5%....%90	
Tightening Torque	M _{max}		4,5 Nm	
Cable Cross-sectional area (max.)			35 mm ² Solid / Stranded / 25 mm ² Flexible	
For mounting on			35 mm DIN Rail EN 60715	
Casing Material			thermoplastic, UL 94 V-0	
Degree of protection			IP20	

Specific Features				
Modular			YES	
Fault Indicators			Green for ok / Red for fault	
Remote Fault Signaling			YES	
Thermal Protection			YES	
Warranty			5 YEARS	



CIRCUIT DIAGRAM

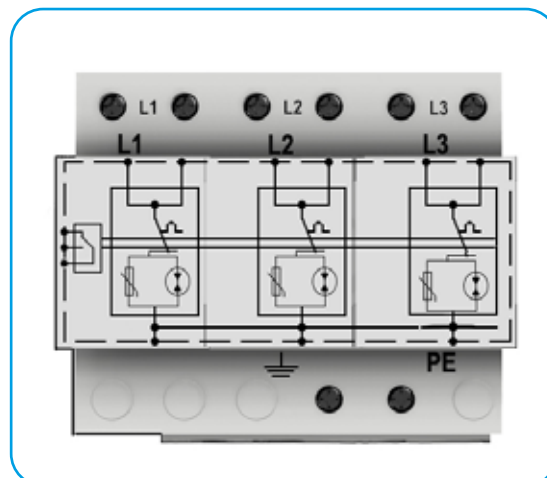

DIMENSIONS

Product Weight:	610 gr
Packaged Weight:	650 gr
Package Dimensions (ExBxY)	80x115x105 mm.

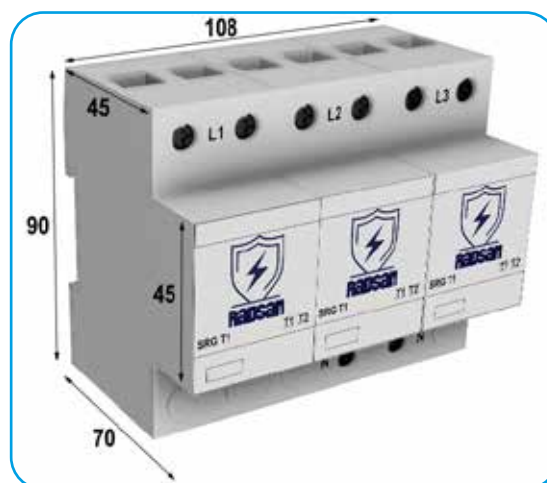

CONNECTION DIAGRAM

Series

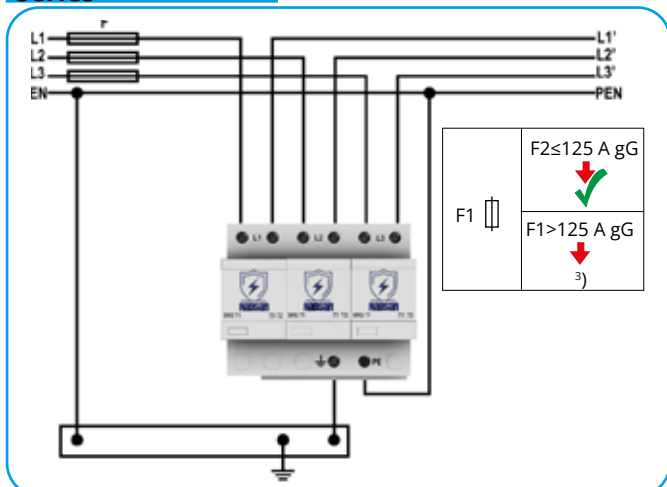

Parallel

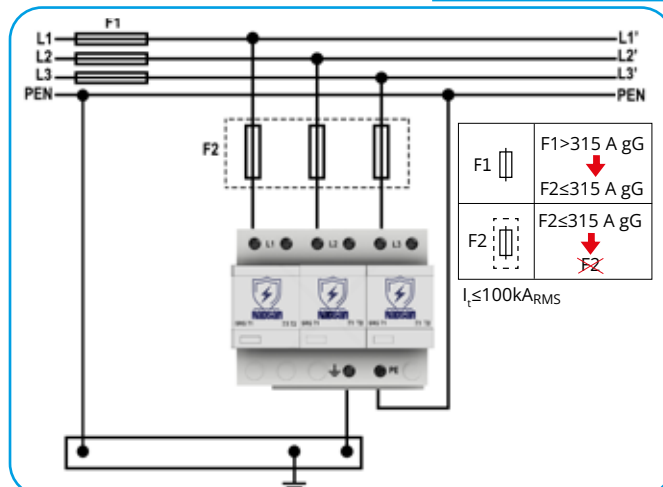



- High level protection is provided by hybrid technology in which varistors and GDT are used together.
- Thanks to its compact design, SPD can be used easily even in the narrowest panels.
- Fault status can be monitored with the indicators on the SPD.
- With the dry contact output, the fault status can be monitored remotely.
- Designed and manufactured in Turkiye.
- 5 years of warranty
- **TUV certificated**



T1+T2 Class SPD according to EN 61643-11.

		SRG T1 2P 150	SRG T1 2P 275	SRG T1 2P 385
Electrical Features				
Nominal AC Voltage (50/60Hz)	Un	130V	240V	230V
Max. Continuous Operating Voltage (L-N)	Uc	150V	275V	385V
Nominal discharge current (8/20µs)	In	50 kA		
Max. discharge current (8/20µs)	Imax	160 kA		
Lightning impulse current (10/350µs)	Iimp	50 kA		
Voltage protection level	Up	≤0,8 kV	≤1,3 kV	≤1,5 kV
Response time	tA	≤25ns / ≤100ns		
Max. backup fuse		315 A gL/gG		
Temporary overvoltage- 120 min. (L-N)	UT	235V	440V	526V
Temporary overvoltage-200 ms (N-PE)	UT	1200V		
Follow current extinguishing capability (N-PE)	I _{fi}	100 A _{RMS}		
Mechanical Features				
Operating temperature range	Ta	-40 C° to +80 C°		
Humidity	RH	5%...%90		
Tightening Torque	Mmax	4,5 Nm		
Cable Cross-sectional area (max.)		35 mm ² Solid / Stranded / 25 mm ² Flexible		
For mounting on		35 mm DIN Rail EN 60715		
Casing Material		Thermoplastic, UL 94 V-0		
Degree of protection		IP20		
Specific Features				
Modular		YES		
Fault Indicators		Green for ok / Red for fault		
Remote Fault Signaling		YES		
Thermal Protection		YES		
Warranty		5 YEARS		



CIRCUIT DIAGRAM

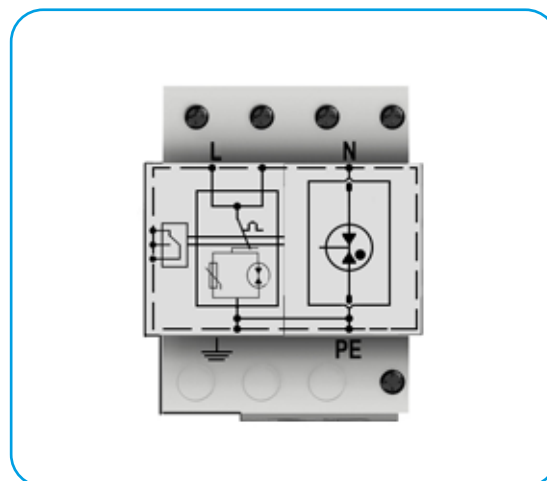

DIMENSIONS

Product Weight:	435 gr
Packaged Weight:	460 gr
Package Dimensions (ExBxY)	80x75x105

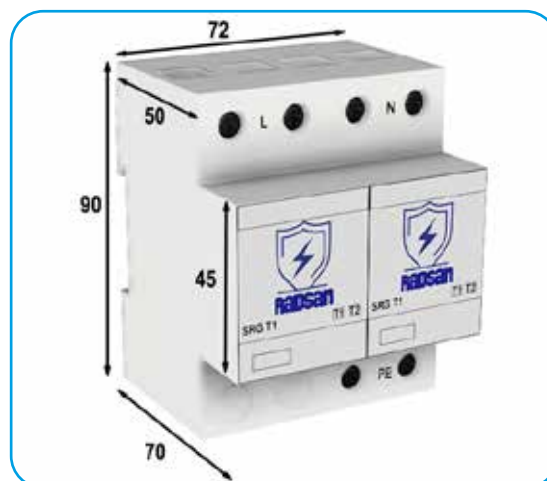

CONNECTION DIAGRAM

Series

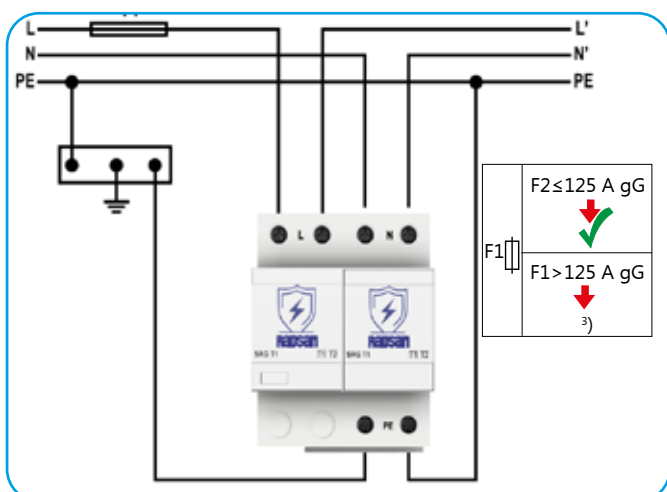

Parallel

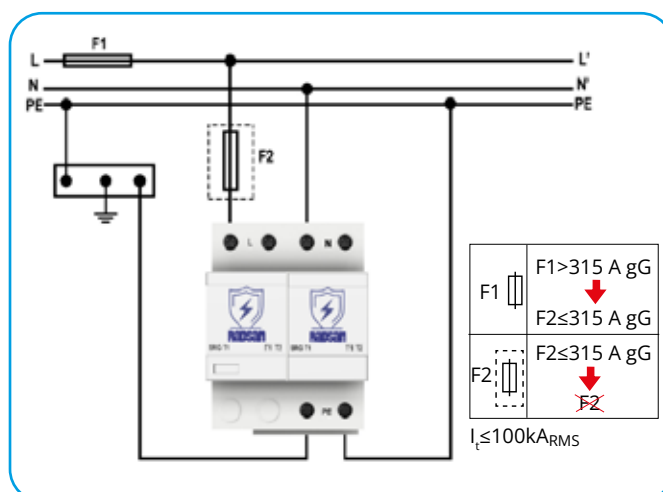



- High level protection is provided by hybrid technology in which varistors and GDT are used together.
- Thanks to its compact design, SPD can be used easily even in the narrowest panels.
- Fault status can be monitored with the indicators on the SPD.
- With the dry contact output, the fault status can be monitored remotely.
- Designed and manufactured in Turkiye.
- 5 years of warranty
- **TUV certificated**



T1+T2 Class SPD according to EN 61643-11.

		SRG T1 1P 150	SRG T1 1P 275	SRG T1 1P 385
Electrical Features				
Nominal AC Voltage (50/60Hz)	Un	130V	240V	230V
Max. Continuous Operating Voltage (L-N)	Uc	150V	275V	385V
Nominal discharge current (8/20µs)	In	50 kA		
Max. discharge current (8/20µs)	I _{max}	160 kA		
Lightning impulse current (10/350µs)	I _{imp}	50 kA		
Voltage protection level	Up	≤0,8 kV	≤1,3 kV	≤1,5 kV
Response time	t _A	≤25ns / ≤100ns		
Max. backup fuse		315 A gL/gG		
Temporary overvoltage- 120 min. (L-N)	UT	235V	440V	526V
Temporary overvoltage-200 ms (N-PE)	UT	1200V		
Follow current extinguishing capability (N-PE)	I _{fi}	100 A _{RMS}		
Mechanical Features				
Operating temperature range	T _a	-40 C° to +80 C°		
Humidity	RH	5%...%90		
Tightening Torque	M _{max}	4,5 Nm		
Cable Cross-sectional area (max.)		35 mm ² Solid / Stranded / 25 mm ² Flexible		
For mounting on		35 mm DIN Rail EN 60715		
Casing Material		Thermoplastic, UL 94 V-0		
Degree of protection		IP20		
Specific Features				
Modular		YES		
Fault Indicators		Green for ok / Red for fault		
Remote Fault Signaling		YES		
Thermal Protection		YES		
Warranty		5 YEARS		



CIRCUIT DIAGRAM

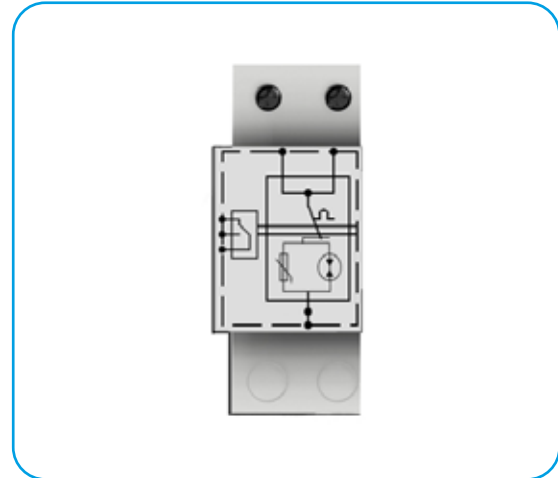

DIMENSIONS

Product Weight:	210 gr
Packaged Weight:	235 gr
Package Dimensions (ExBxY)	80x40x105 mm.

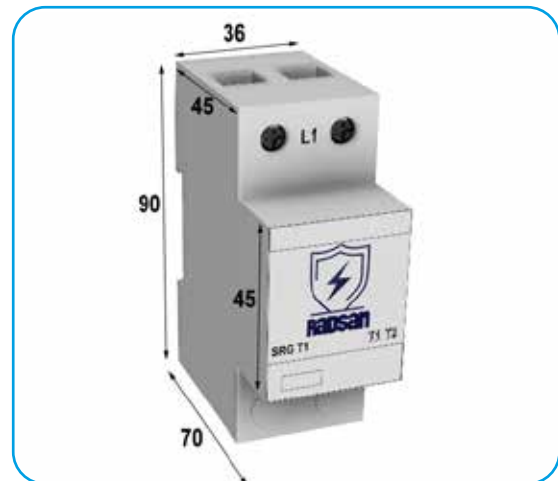



- High level protection is provided by hybrid technology in which varistors and GDT are used together.
- Thanks to its compact design, SPD can be used easily even in the narrowest panels.
- Low maintenance cost thanks to modular design.
- Fault status can be monitored with the indicators on the SPD.
- With the dry contact output, the fault status can be monitored remotely.
- Designed and manufactured in Turkiye.
- 5 years of warranty

3+1

TT
TN-S

T1+T2 Class SPD according to EN 61643-11.

Combination: 3+1, TT and TN-S Network

		SRG T1 3P+N V150	SRG T1 3P+N V275	SRG T1 3P+N V320
Electrical Features				
Nominal AC Voltage (50/60Hz)	Un	130V	240V	300V
Max. Continuous Operating Voltage (L-N)	Uc	150V	275V	320V
Nominal discharge current (8/20µs)	In	20 kA (L-N)		
Max. discharge current (8/20µs)	I _{max}	100 kA		
Lightning impulse current (10/350µs)	I _{imp}	12,5 kA (L-N) / 25 kA (N-PE)		
Voltage protection level	Up	≤0,8 kV	≤1,5 kV	≤1,5 kV
Response time	t _A	≤25ns / ≤100ns		
Max. backup fuse		125 A gL/gG		
Temporary overvoltage- 120 min. (L-N)	UT	235V	440V	526V
Temporary overvoltage-200 ms (N-PE)	UT	1200V		
Follow current extinguishing capability (N-PE)	I _{fi}	100 A _{RMS}		
Mechanical Features				
Operating temperature range	T _a	-40 C° to +80 C°		
Humidity	RH	5%...%90		
Tightening Torque	M _{max}	4,5 Nm		
Cable Cross-sectional area (max.)		35 mm ² Solid / Stranded / 25 mm ² Flexible		
For mounting on		35 mm DIN Rail EN 60715		
Casing Material		Thermoplastic, UL 94 V-0		
Degree of protection		IP20		
Specific Features				
Modular		YES		
Fault Indicators		Green for ok / Red for fault		
Remote Fault Signaling		YES		
Thermal Protection		YES		
Warranty		5 YEARS		



CIRCUIT DIAGRAM

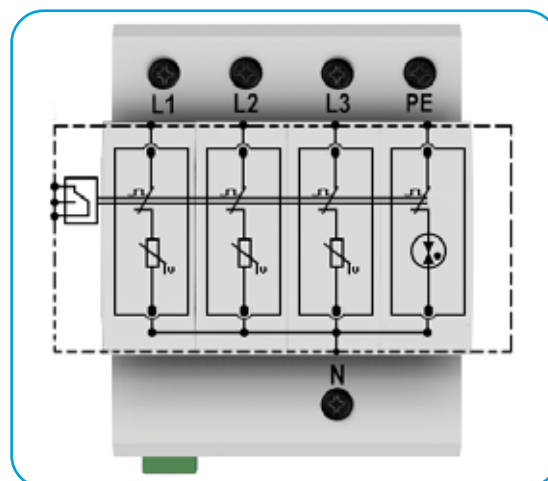

DIMENSIONS

Product Weight:	500 gr
Packaged Weight:	530 gr
Package Dimensions (ExBxY)	80x100x75

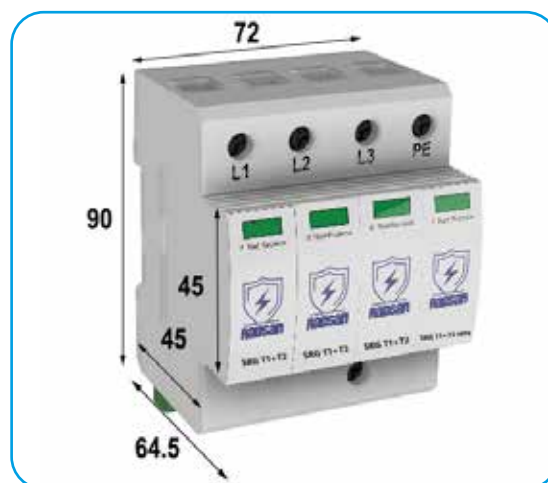

CONNECTION DIAGRAM

TN-S

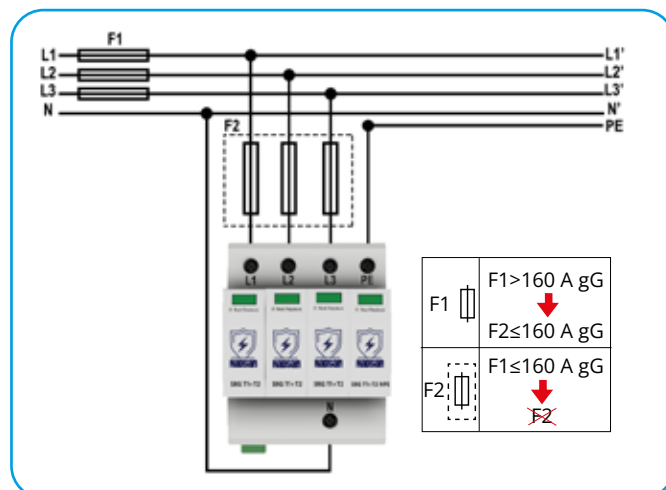
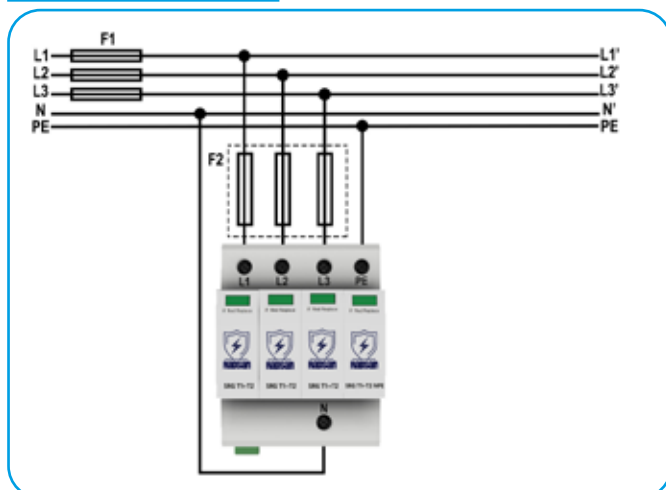



- High level protection is provided by hybrid technology in which varistors and GDT are used together.
- Thanks to its compact design, SPD can be used easily even in the narrowest panels.
- Low maintenance cost thanks to modular design.
- Fault status can be monitored with the indicators on the SPD.
- With the dry contact output, the fault status can be monitored remotely.
- Designed and manufactured in Turkiye.
- 5 years of warranty

T1+T2 Class SPD according to EN 61643-11.

1+1

TT
TN-S

		SRG T1 1P+N V150	SRG T1 1P+N V275	SRG T1 1P+N V320
Electrical Features				
Nominal AC Voltage (50/60Hz)	Un	130V	240V	300V
Max. Continuous Operating Voltage (L-N)	Uc	150V	275V	320V
Nominal discharge current (8/20µs)	In	20 kA (L-N)		
Max. discharge current (8/20µs)	I _{max}	60 kA		
Lightning impulse current (10/350µs)	I _{imp}	12,5 kA (L-N) / 25 kA (N-PE)		
Voltage protection level	Up	≤0,8 kV	≤1,5 kV	≤1,5 kV
Response time	t _A	≤25ns		
Max. backup fuse		125 A gL/gG		
Temporary overvoltage- 120 min. (L-N)	UT	235V	440V	526V
Temporary overvoltage-200 ms (N-PE)	UT	1200V		
Follow current extinguishing capability (N-PE)	I _{fi}	100 A _{RMS}		
Mechanical Features				
Operating temperature range	T _a	-40 C° to +80 C°		
Humidity	RH	5%....%90		
Tightening Torque	M _{max}	4,5 Nm		
Cable Cross-sectional area (max.)		35 mm ² Solid / Stranded / 25 mm ² Flexible		
For mounting on		35 mm DIN Rail EN 60715		
Casing Material		Thermoplastic, UL 94 V-0		
Degree of protection		IP20		
Specific Features				
Modular		YES		
Fault Indicators		Green for ok / Red for fault		
Remote Fault Signaling		YES		
Thermal Protection		YES		
Warranty		5 YEARS		



CIRCUIT DIAGRAM

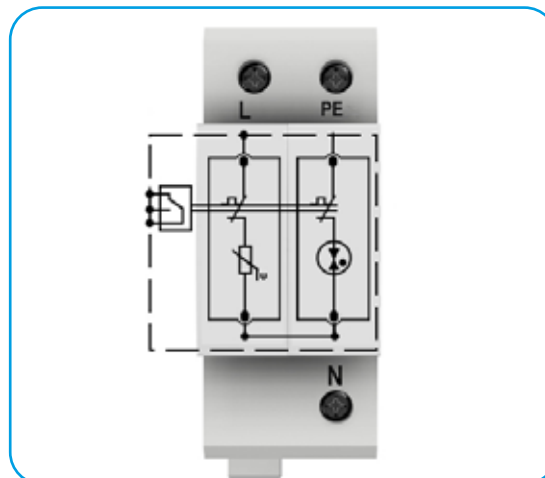

DIMENSIONS

Product Weight:	230 gr
Packaged Weight:	250 gr
Package Dimensions (ExBxY)	40x100x75 mm.

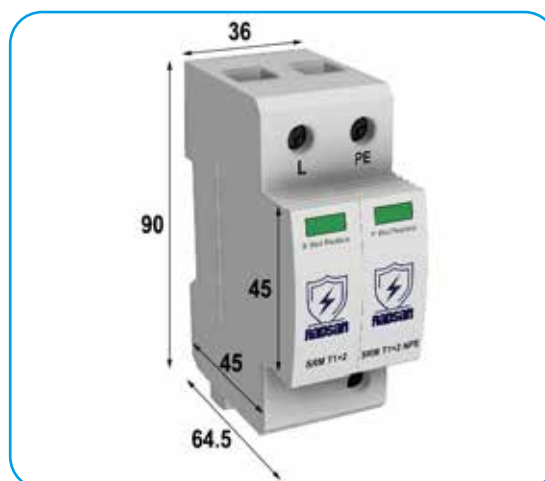

CONNECTION DIAGRAM

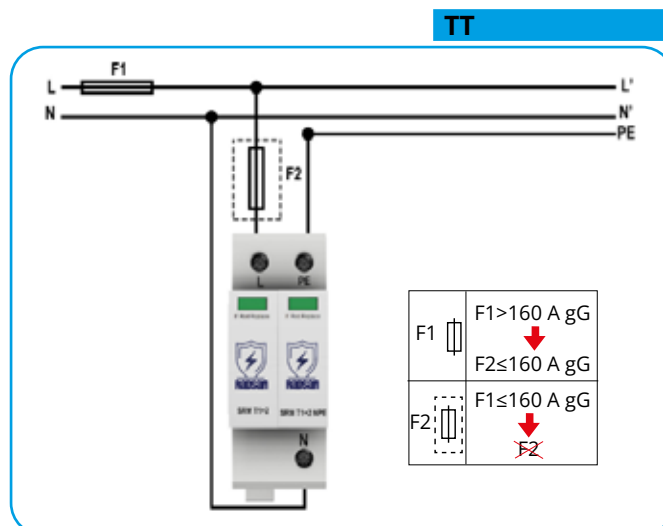
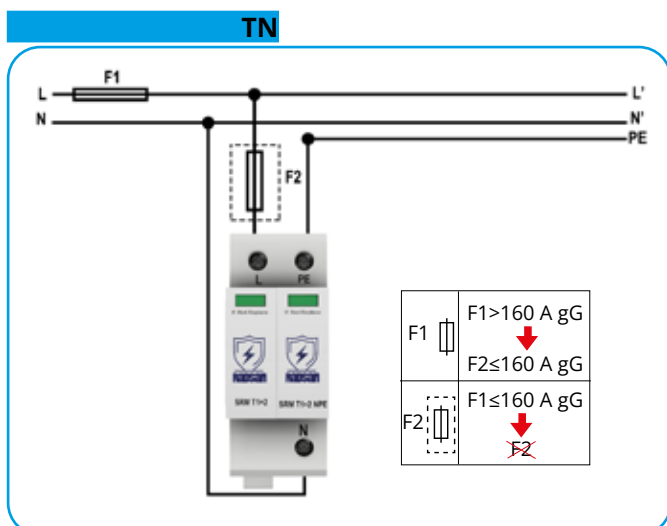



- High level protection is provided by hybrid technology in which varistors and GDT are used together.
- Thanks to its compact design, SPD can be used easily even in the narrowest panels.
- Low maintenance cost thanks to modular design.
- Fault status can be monitored with the indicators on the SPD.
- With the dry contact output, the fault status can be monitored remotely.
- Designed and manufactured in Turkiye.
- 5 years of warranty

T1+T2 Class SPD according to EN 61643-11.

4+0

TN-S

		SRG T1 4P V150	SRG T1 4P V275	SRG T1 4P V320
Electrical Features				
Nominal AC Voltage (50/60Hz)	Un	130V	240V	300V
Max. Continuous Operating Voltage (L-N)	Uc	150V	275V	320V
Nominal discharge current (8/20µs)	In		20 kA	
Max. discharge current (8/20µs)	I _{max}		60 kA	
Lightning impulse current (10/350µs)	I _{imp}		12,5 kA	
Voltage protection level	Up	≤1 kV	≤1,5 kV	≤1,7 kV
Response time	t _A		≤25ns	
Max. backup fuse			315 A / 250 A gL/gG	
TOV withstand 5s.	UT	175V	337V	403V
TOV 120m.	UT	229V	442V	529V
Mechanical Features				
Operating temperature range	T _a		-40 C° to +80 C°	
Humidity	RH		5%...%90	
Tightening Torque	M _{max}		4,5 Nm	
Cable Cross-sectional area (max.)			35 mm ² Solid / Stranded / 25 mm ² Flexible	
For mounting on			35 mm DIN Rail EN 60715	
Casing Material			Thermoplastic, UL 94 V-0	
Degree of protection			IP20	
Specific Features				
Modular			YES	
Fault Indicators			Green for ok / Red for fault	
Remote Fault Signaling			YES	
Thermal Protection			YES	
Warranty			5 YEARS	



CIRCUIT DIAGRAM

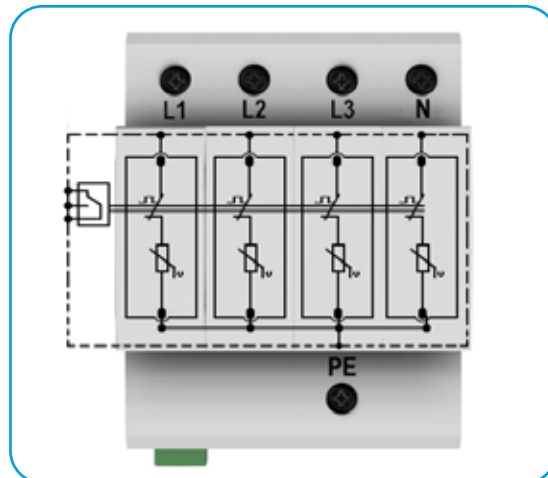

DIMENSIONS

Product Weight:	500 gr
Packaged Weight:	530 gr
Package Dimensions (ExBxY)	80x100x75

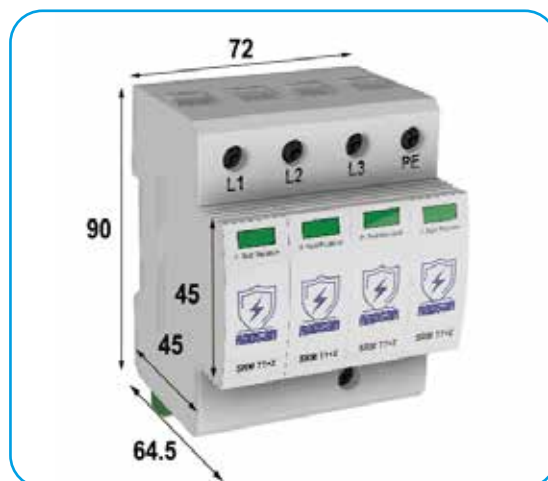

CONNECTION DIAGRAM

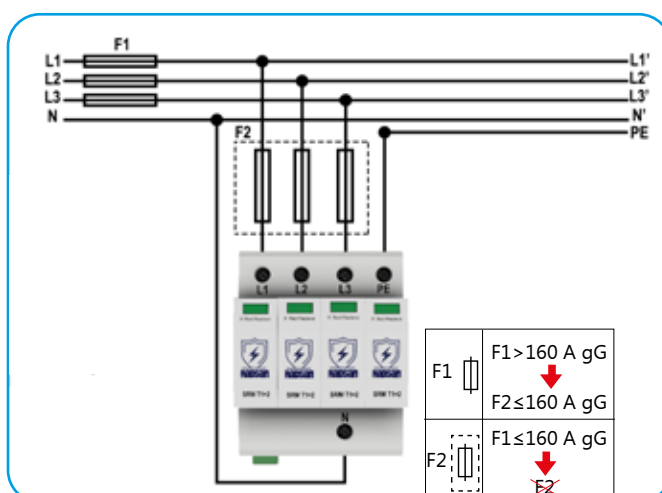



- High level protection is provided by hybrid technology in which varistors and GDT are used together.
- Thanks to its compact design, SPD can be used easily even in the narrowest panels.
- Low maintenance cost thanks to modular design.
- Fault status can be monitored with the indicators on the SPD.
- With the dry contact output, the fault status can be monitored remotely.
- Designed and manufactured in Turkiye.
- 5 years of warranty

3+0
TN-C
T1+T2 Class SPD according to EN 61643-11.

		SRG T1 3P V150	SRG T1 3P V275	SRG T1 3P V320
Electrical Features				
Nominal AC Voltage (50/60Hz)	Un	130V	240V	300V
Max. Continuous Operating Voltage (L-N)	Uc	150V	275V	320V
Nominal discharge current (8/20µs)	In	12,5 kA		
Max. discharge current (8/20µs)	I _{max}	60 kA		
Lightning impulse current (10/350µs)	I _{imp}	12,5 kA		
Voltage protection level	Up	≤1 kV	≤1,5 kV	≤1,5 kV
Response time	tA	≤25ns		
Max. backup fuse		125 A gL/gG		
TOV withstand 5s.	UT	175V	337V	403V
TOV 120m.	UT	229V	442V	529V
Mechanical Features				
Operating temperature range	Ta	-40 C° to +80 C°		
Humidity	RH	5%...%90		
Tightening Torque	M _{max}	4,5 Nm		
Cable Cross-sectional area (max.)		35 mm ² Solid / Stranded / 25 mm ² Flexible		
For mounting on		35 mm DIN Rail EN 60715		
Casing Material		Thermoplastic, UL 94 V-0		
Degree of protection		IP20		
Specific Features				
Modular		YES		
Fault Indicators		Green for ok / Red for fault		
Remote Fault Signaling		YES		
Thermal Protection		YES		
Warranty		5 YEARS		



CIRCUIT DIAGRAM

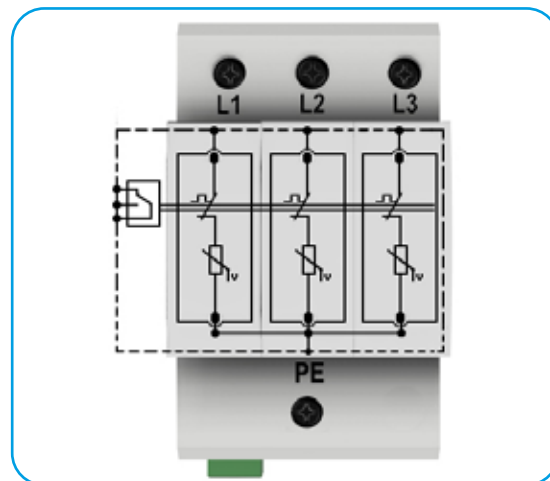

DIMENSIONS

Product Weight:	385 gr
Packaged Weight:	415 gr
Package Dimensions (ExBxY)	60x100x75



CONNECTION DIAGRAM

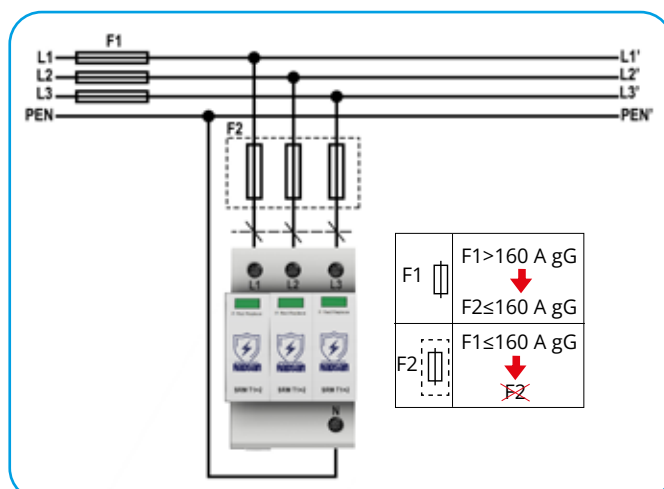



- High level protection is provided by hybrid technology in which varistors and GDT are used together.
- Thanks to its compact design, SPD can be used easily even in the narrowest panels.
- Low maintenance cost thanks to modular design.
- Fault status can be monitored with the indicators on the SPD.
- With the dry contact output, the fault status can be monitored remotely.
- Designed and manufactured in Türkiye.
- 5 years of warranty

2+0

TN-C

T1+T2 Class SPD according to EN 61643-11.

		SRG T1 2P V150	SRG T1 2P V275	SRG T1 2P V320
Electrical Features				
Nominal AC Voltage (50/60Hz)	Un	130V	240V	300V
Max. Continuous Operating Voltage (L-N)	Uc	150V	275V	320V
Nominal discharge current (8/20µs)	In		12,5 kA	
Max. discharge current (8/20µs)	I _{max}		60 kA	
Lightning impulse current (10/350µs)	I _{imp}		12,5 kA	
Voltage protection level	Up	≤1 kV	≤1,5 kV	≤1,5 kV
Response time	t _A		≤25ns	
Max. backup fuse			125 A gL/gG	
TOV withstand 5s.	UT	175V	337V	403V
TOV 120m.	UT	229V	442V	529V
Mechanical Features				
Operating temperature range	T _a		-40 C° to +80 C°	
Humidity	RH		5%...%90	
Tightening Torque	M _{max}		4,5 Nm	
Cable Cross-sectional area (max.)			35 mm ² Solid / Stranded / 25 mm ² Flexible	
For mounting on			35 mm DIN Rail EN 60715	
Casing Material			Thermoplastic, UL 94 V-0	
Degree of protection			IP20	
Specific Features				
Modular			YES	
Fault Indicators			Green for ok / Red for fault	
Remote Fault Signaling			YES	
Thermal Protection			YES	
Warranty			5 YEARS	



CIRCUIT DIAGRAM

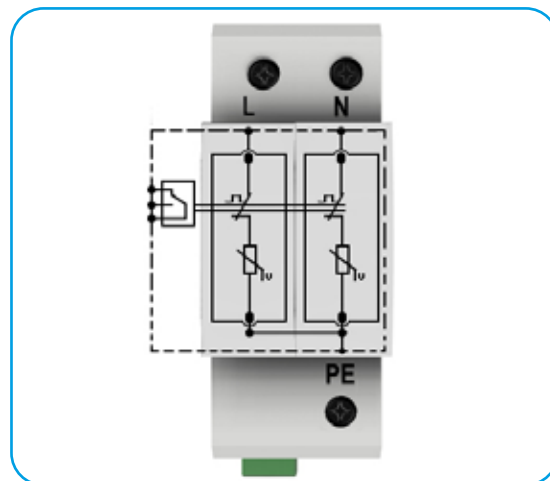

DIMENSIONS

Product Weight:	230 gr
Packaged Weight:	250 gr
Package Dimensions (ExBxY)	40x100x75 mm.

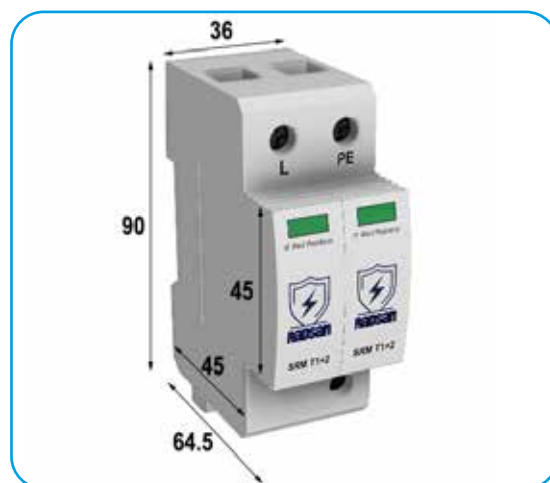

CONNECTION DIAGRAM

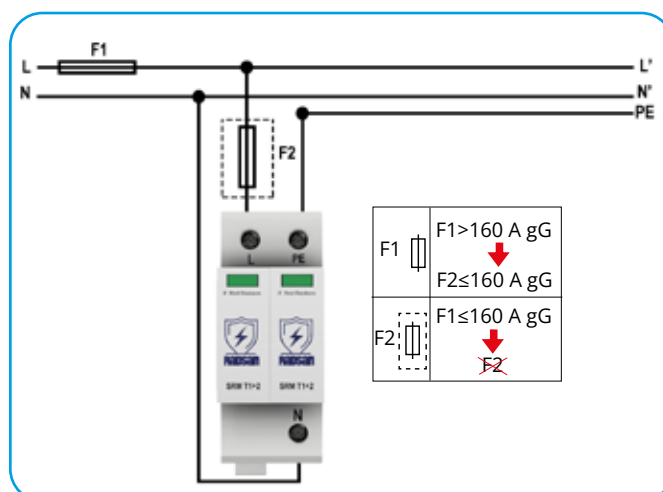



- High level protection is provided by hybrid technology in which varistors and GDT are used together.
- Thanks to its compact design, SPD can be used easily even in the narrowest panels.
- Low maintenance cost thanks to modular design.
- Fault status can be monitored with the indicators on the SPD.
- With the dry contact output, the fault status can be monitored remotely.
- Designed and manufactured in Turkiye.
- 5 years of warranty

1+0

T1+T2 Class SPD according to EN 61643-11.

SRG T1 P V150

SRG T1 P V275

SRG T1 P V320

Electrical Features

		SRG T1 P V150	SRG T1 P V275	SRG T1 P V320
Nominal AC Voltage (50/60Hz)	Un	130V	240V	300V
Max. Continuous Operating Voltage (L-N)	Uc	150V	275V	320V
Nominal discharge current (8/20µs)	In		12,5 kA	
Max. discharge current (8/20µs)	I _{max}		60 kA	
Lightning impulse current (10/350µs)	I _{imp}		12,5 kA	
Voltage protection level	Up	≤1 kV	≤1,5 kV	≤1,5 kV
Response time	t _A		≤25ns	
Max. backup fuse			125 A gL/gG	
TOV withstand 5s.	UT	175V	337V	403V
TOV 120m.	UT	229V	442V	529V

Mechanical Features

Operating temperature range	T _a		-40 C° to +80 C°	
Humidity	RH		5%...%90	
Tightening Torque	M _{max}		4,5 Nm	
Cable Cross-sectional area (max.)			35 mm ² Solid / Stranded / 25 mm ² Flexible	
For mounting on			35 mm DIN Rail EN 60715	
Casing Material			Thermoplastic, UL 94 V-0	
Degree of protection			IP20	

Specific Features

Modular			YES	
Fault Indicators			Green for ok / Red for fault	
Remote Fault Signaling			YES	
Thermal Protection			YES	
Warranty			5 YEARS	



CIRCUIT DIAGRAM

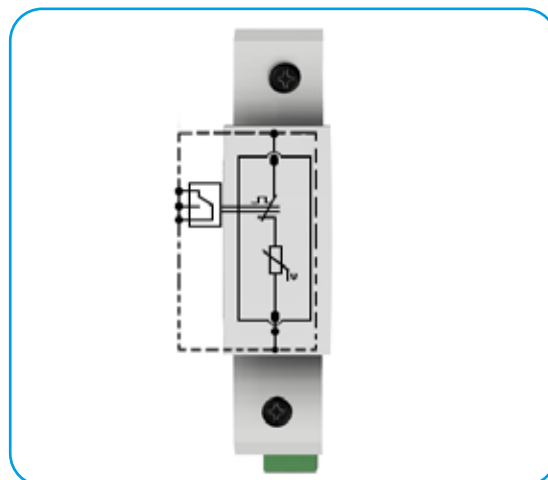

DIMENSIONS

Product Weight:	140 gr
Packaged Weight:	160 gr
Package Dimensions (ExBxY)	20x100x75 mm.





- Superior protection is provided by high performance GDTs.
- Thanks to its compact design, SPD can be used easily even in the narrowest panels.
- Fault status can be monitored with the indicators on the SPD.
- With the dry contact output, the fault status can be monitored remotely.
- Designed and manufactured in Turkiye.
- 5 years of warranty

3+1
**TT
TN-S**

**T1 Class SPD according to EN 61643-11.
Combination: 3+1, TT and TN-S Network**

		SRG T1 150 3+1	SRG T1 255 3+1	SRG T1 275 3+1
Electrical Features				
Nominal AC Voltage (50/60Hz)	Un	130V	240 V	240 V
Max. Continuous Operating Voltage (N-PE)	Uc	150V	255 V	275 V
Lightning impulse current (10/350µs)	limp	25 kA (L-N) / 100 kA (N-PE)		
Voltage protection level	Up	≤1,5 kV	≤1,5 kV	≤2,5 kV
Response time	tA	≤100ns		
Max. backup fuse		500 A gL/gG		
Temporary overvoltage- 120 min. (L-N)	UT	230 V	440 V	530 V
Follow current extinguishing capability (N-PE)	Ifi	50 kA _{RMS}		
Mechanical Features				
Operating temperature range	Ta	-40 C° to +80 C°		
Humidity	RH	5%...%90		
Tightening Torque	Mmax	4,5 Nm		
Cable Cross-sectional area (max.)		10-35 mm ² Solid / Stranded / Fleksible		
For mounting on		35 mm DIN Rail EN 60715		
Casing Material		Thermoplastic, UL 94 V-0		
Degree of protection		IP20		
Specific Features				
Modular		NO		
Fault Indicators		Green for ok / Red for fault		
Remote Fault Signaling		YES		
Thermal Protection		YES		
Warranty		5 YEARS		



CIRCUIT DIAGRAM

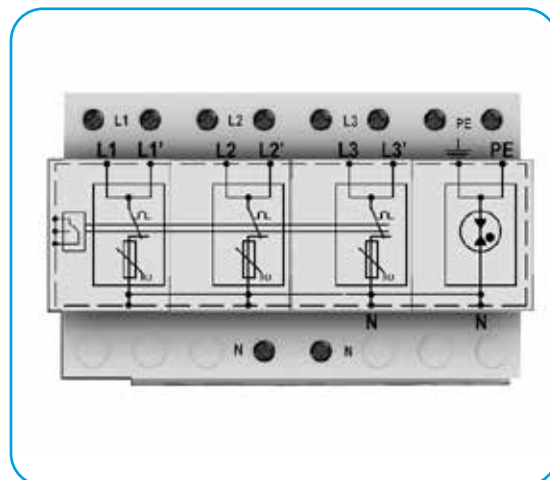

DIMENSIONS

Product Weight:	1075 gr
Packaged Weight:	1120 gr
Package Dimensions (ExBxY)	80x150x105 mm.

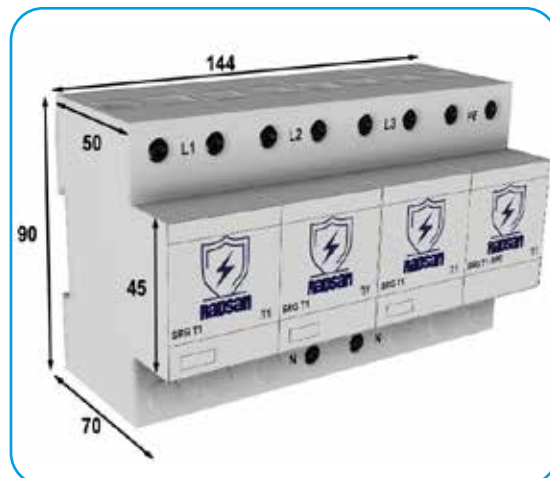

CONNECTION DIAGRAM

Series

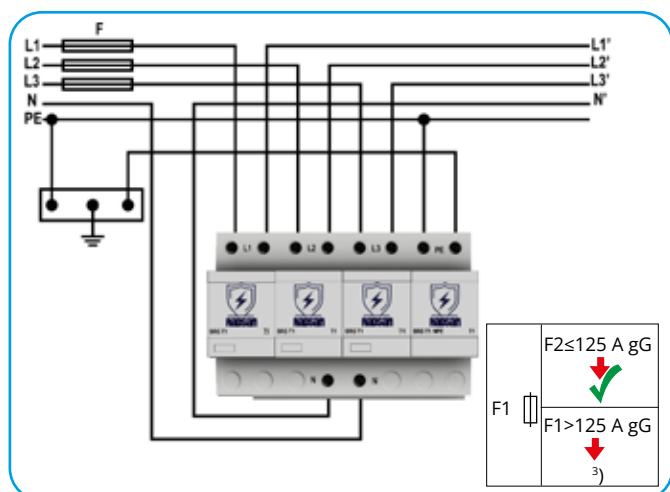

Parallel

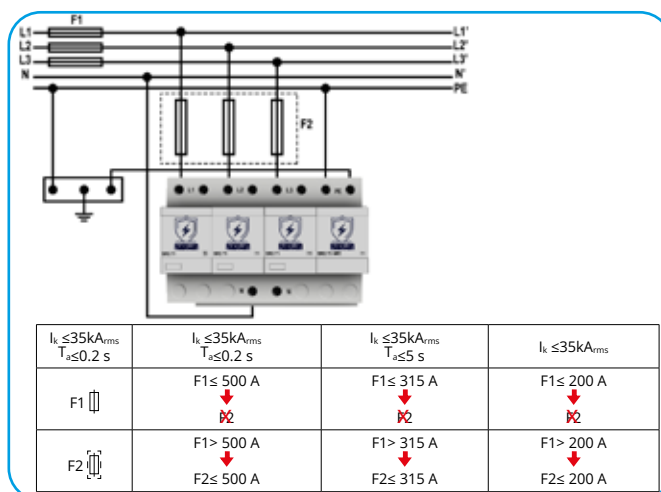



- Superior protection is provided by high performance GDTs.
- Thanks to its compact design, SPD can be used easily even in the narrowest panels.
- Fault status can be monitored with the indicators on the SPD.
- With the dry contact output, the fault status can be monitored remotely.
- Designed and manufactured in Turkiye.
- 5 years of warranty

1+1
**TT
TN-S**

T1 Class SPD according to EN 61643-11.

		SRG T1 150 1+1	SRG T1 255 1+1	SRG T1 275 1+1
Electrical Features				
Nominal AC Voltage (50/60Hz)	Un	130V	240 V	240 V
Max. Continuous Operating Voltage (L-N)	Uc	150V	255 V	275 V
Lightning impulse current (10/350µs)	Iimp	25 kA (L-N) / 100 kA (N-PE)		
Voltage protection level	Up	≤1,5 kV	≤1,5 kV	≤2,5 kV
Response time	tA	≤100ns		
Max. backup fuse		500 A gL/gG		
Temporary overvoltage- 120 min. (L-N)	UT	230 V	440 V	530 V
Follow current extinguishing capability (N-PE)	I _{fi}	50 kA _{RMS}		
Mechanical Features				
Operating temperature range	Ta	-40 C° to +80 C°		
Humidity	RH	5%...%90		
Tightening Torque	Mmax	4,5 Nm		
Cable Cross-sectional area (max.)		10-35 mm ² Solid / Stranded / Fleksible		
For mounting on		35 mm DIN Rail EN 60715		
Casing Material		Thermoplastic, UL 94 V-0		
Degree of protection		IP20		
Specific Features				
Modular		HAYIR		
Fault Indicators		Green for ok / Red for fault		
Remote Fault Signaling		YES		
Thermal Protection		YES		
Warranty		5 YEARS		



CIRCUIT DIAGRAM

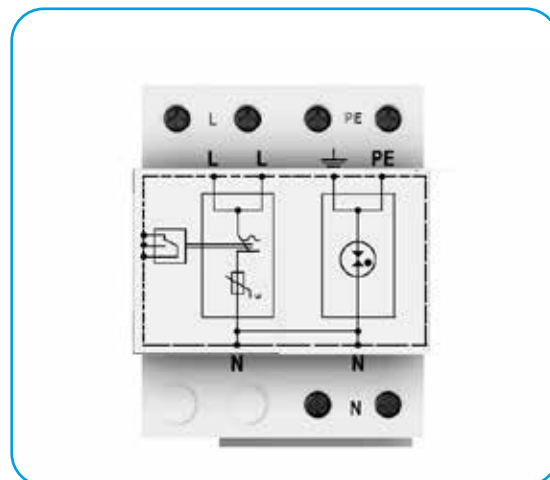

DIMENSIONS

Product Weight:	500 gr
Packaged Weight:	525 gr
Package Dimensions (ExBxY)	80x70x105 mm.

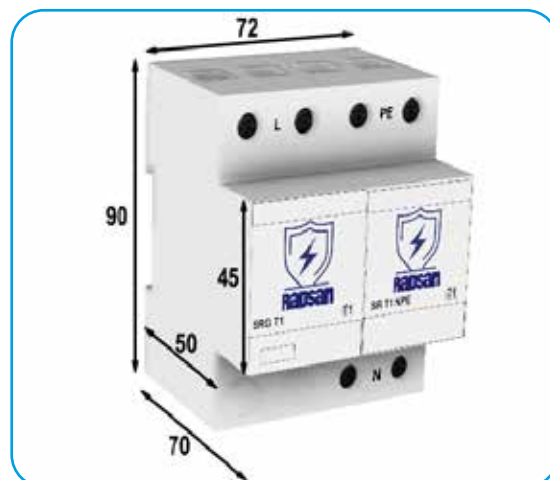

CONNECTION DIAGRAM

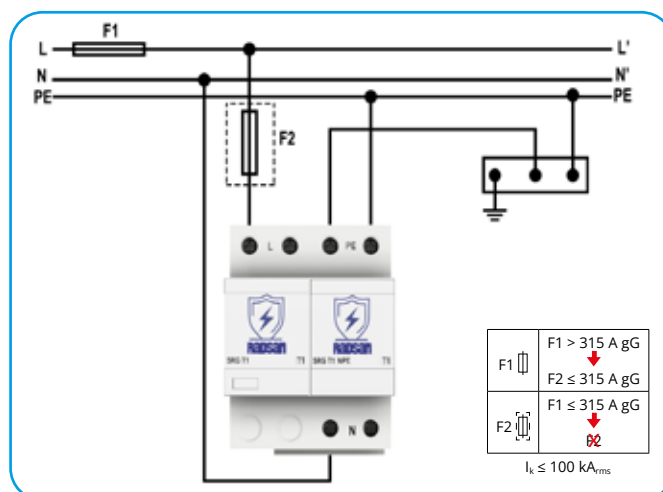
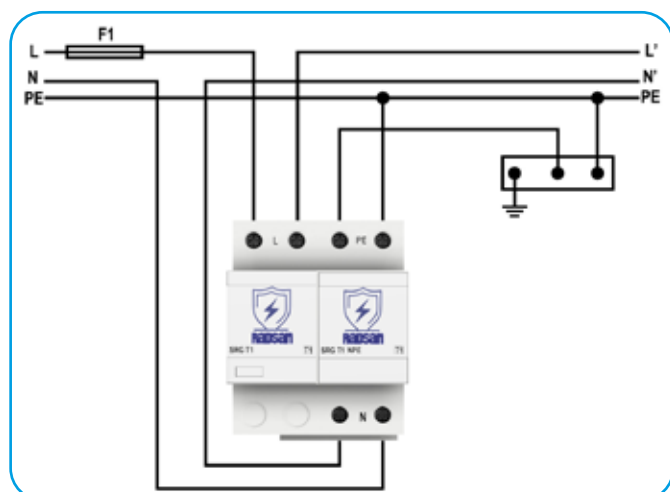



- Superior protection is provided by high performance GDTs.
- Thanks to its compact design, SPD can be used easily even in the narrowest panels.
- Fault status can be monitored with the indicators on the SPD.
- With the dry contact output, the fault status can be monitored remotely.
- Designed and manufactured in Turkiye.
- 5 years of warranty

4+0
TN-S

T1 Class SPD according to EN 61643-11.

		SRG T1 150 4+0	SRG T1 255 4+0	SRG T1 275 4+0
Electrical Features				
Nominal AC Voltage (50/60Hz)	Un	130V	240 V	240 V
Max. Continuous Operating Voltage (L-N)	Uc	150V	255 V	275 V
Lightning impulse current (10/350µs)	Iimp	50 kA		
Voltage protection level	Up	≤1,5 kV	≤2,5 kV	≤2,5 kV
Response time	tA	≤100ns		
Max. backup fuse		500 A gL/gG		
Temporary overvoltage- 120 min. (L-N)	UT	230 V	440 V	530 V
Follow current extinguishing capability (N-PE)	I _{fi}	50 kA _{RMS}		
Mechanical Features				
Operating temperature range	Ta	-40 C° to +80 C°		
Humidity	RH	5%...%90		
Tightening Torque	Mmax	4,5 Nm		
Cable Cross-sectional area (max.)		10-35 mm ² Solid / Stranded / Fleksible		
For mounting on		35 mm DIN Rail EN 60715		
Casing Material		Thermoplastic, UL 94 V-0		
Degree of protection		IP20		
Specific Features				
Modular		HAYIR		
Fault Indicators		Green for ok / Red for fault		
Remote Fault Signaling		YES		
Thermal Protection		YES		
Warranty		5 YEARS		



CIRCUIT DIAGRAM

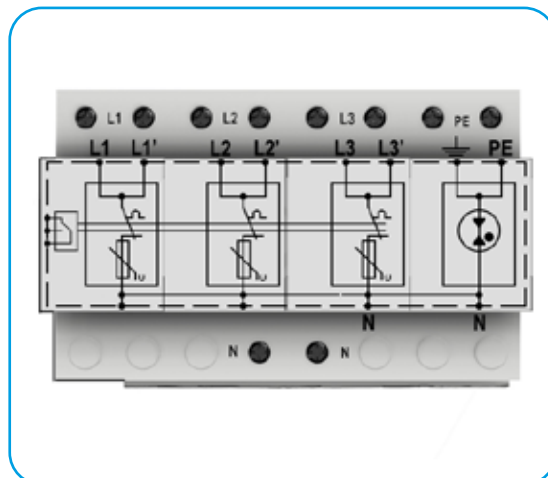

DIMENSIONS

Product Weight:	1075 gr
Packaged Weight:	1120 gr
Package Dimensions (ExBxY)	80x150x105 mm.



CONNECTION DIAGRAM

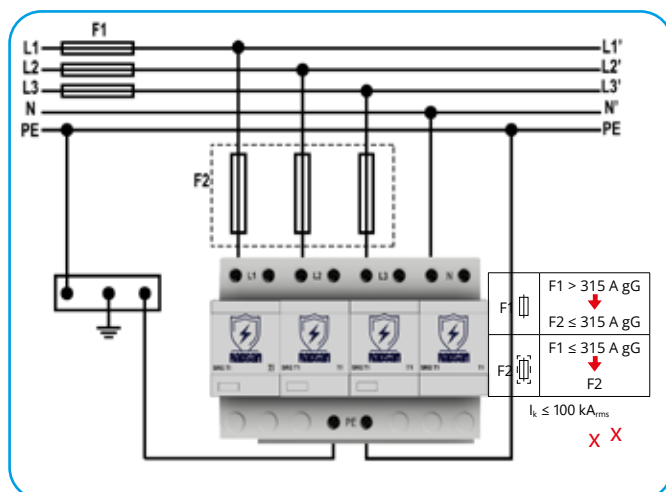
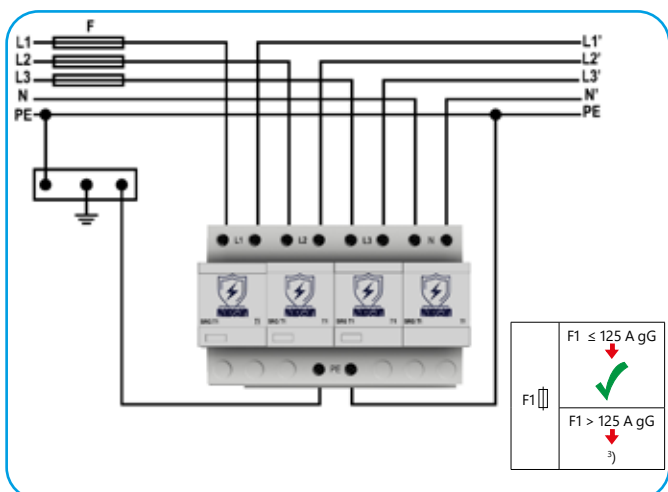



Superior protection is provided by high performance GDTs.

- Kompakt tasarım sayesinde en dar panolarda bile rahatça kullanılabilir.
- Fault status can be monitored with the indicators on the SPD.
- With the dry contact output, the fault status can be monitored remotely.
- Designed and manufactured in Türkiye.
- 5 years of warranty

3+0

TN-C

T1 Class SPD according to EN 61643-11.

		SRG T1 150 3+0	SRG T1 255 3+0	SRG T1 275 3+0
Electrical Features				
Nominal AC Voltage (50/60Hz)	Un	130V	240 V	240 V
Max. Continuous Operating Voltage (L-N)	Uc	150V	255 V	275 V
Lightning impulse current (10/350µs)	Iimp	50 kA		
Voltage protection level	Up	≤1,5 kV	≤2,5 kV	≤2,5 kV
Response time	tA	≤100ns		
Max. backup fuse		500 A gL/gG		
Temporary overvoltage- 120 min. (L-N)	UT	230 V	440 V	530 V
Follow current extinguishing capability (N-PE)	I _{fi}	50 kA _{RMS}		
Mechanical Features				
Operating temperature range	Ta	-40 C° to +80 C°		
Humidity	RH	5%....%90		
Tightening Torque	Mmax	4,5 Nm		
Cable Cross-sectional area (max.)		10-35 mm ² Solid / Stranded / Fleksible		
For mounting on		35 mm DIN Rail EN 60715		
Casing Material		Thermoplastic, UL 94 V-0		
Degree of protection		IP20		
Specific Features				
Modular		HAYIR		
Fault Indicators		Green for ok / Red for fault		
Remote Fault Signaling		YES		
Thermal Protection		YES		
Warranty		5 YEARS		



CIRCUIT DIAGRAM

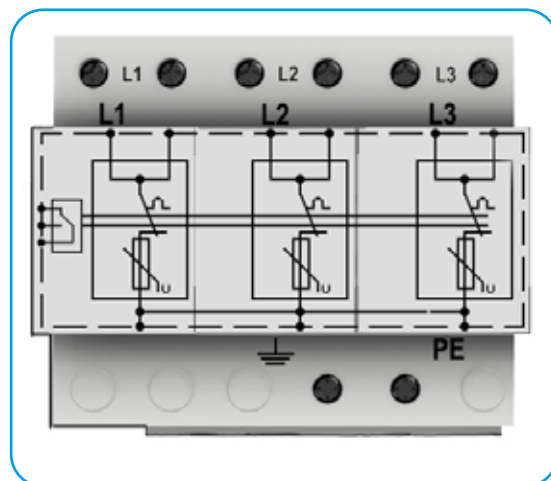

DIMENSIONS

Product Weight:	810 gr
Packaged Weight:	845 gr
Package Dimensions (ExBxY)	80x105x105 mm.

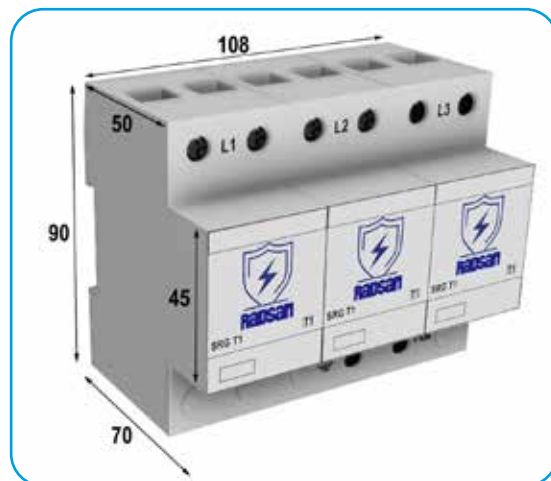

CONNECTION DIAGRAM

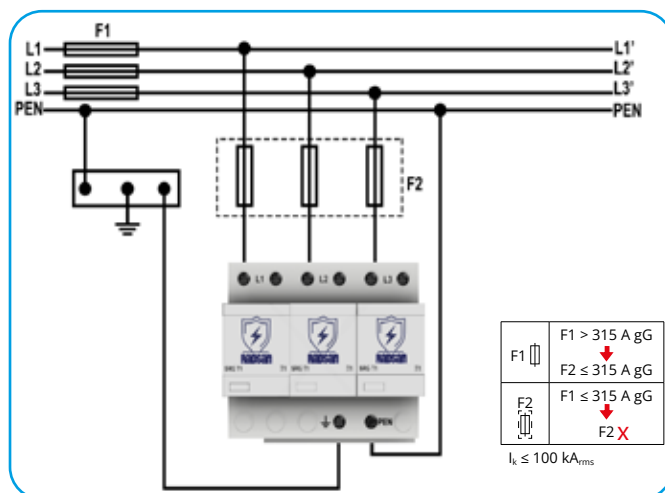
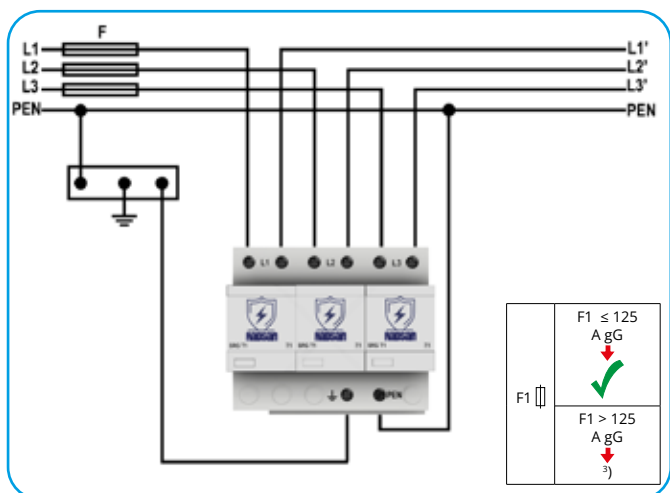



Superior protection is provided by high performance GDTs.

- Kompakt tasarım sayesinde en dar panolarda bile rahatça kullanılabilir.
- Fault status can be monitored with the indicators on the SPD.
- With the dry contact output, the fault status can be monitored remotely.
- Designed and manufactured in Türkiye.
- 5 years of warranty

2+0

TN-C

T1 Class SPD according to EN 61643-11.

		SRG T1 150 2+0	SRG T1 255 2+0	SRG T1 275 2+0
Electrical Features				
Nominal AC Voltage (50/60Hz)	Un	130V	240 V	240 V
Max. Continuous Operating Voltage (L-N)	Uc	150V	255 V	275 V
Lightning impulse current (10/350µs)	Iimp	50 kA		
Voltage protection level	Up	≤1,5 kV	≤2,5 kV	≤2,5 kV
Response time	tA	≤100ns		
Max. backup fuse		500 A gL/gG		
Temporary overvoltage- 120 min. (L-N)	UT	230 V	440 V	530 V
Follow current extinguishing capability (N-PE)	I _{fi}	50 kA _{RMS}		
Mechanical Features				
Operating temperature range	Ta	-40 C° to +80 C°		
Humidity	RH	5%....%90		
Tightening Torque	Mmax	4,5 Nm		
Cable Cross-sectional area (max.)		10-35 mm ² Solid / Stranded / Fleksible		
For mounting on		35 mm DIN Rail EN 60715		
Casing Material		Thermoplastic, UL 94 V-0		
Degree of protection		IP20		
Specific Features				
Modular		HAYIR		
Fault Indicators		Green for ok / Red for fault		
Remote Fault Signaling		YES		
Thermal Protection		YES		
Warranty		5 YEARS		



CIRCUIT DIAGRAM

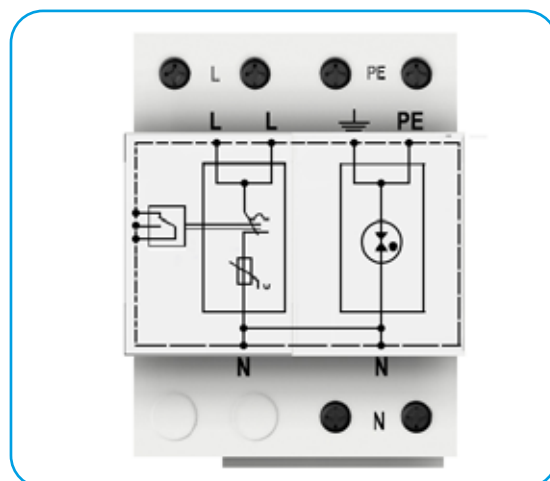

DIMENSIONS

Product Weight:	500 gr
Packaged Weight:	525 gr
Package Dimensions (ExBxY)	80x70x105 mm.

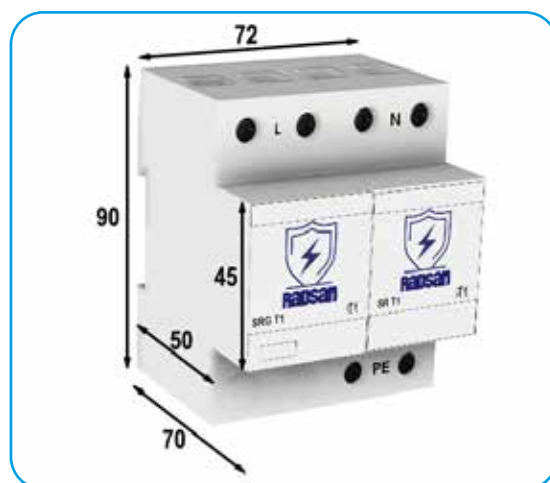

CONNECTION DIAGRAM

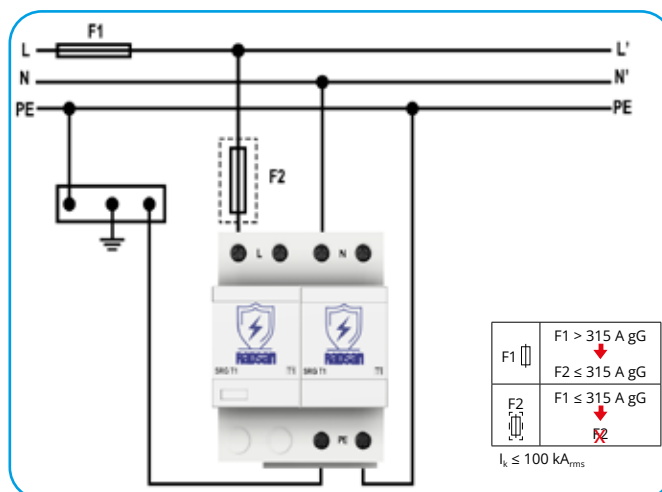
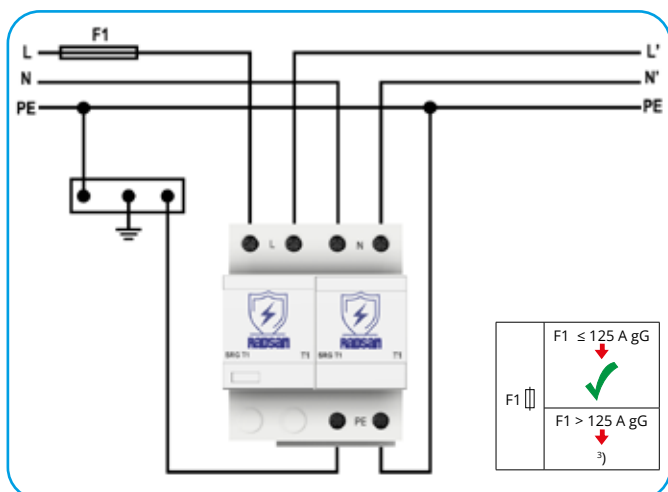



- Superior protection is provided by high performance GDTs.
- Thanks to its compact design, SPD can be used easily even in the narrowest panels.
- Fault status can be monitored with the indicators on the SPD.
- With the dry contact output, the fault status can be monitored remotely.
- Designed and manufactured in Turkiye.
- 5 years of warranty

1+0**TN-C**

T1 Class SPD according to EN 61643-11.

		SRG T1 150 1+0	SRG T1 255 1+0	SRG T1 275 1+0
Electrical Features				
Nominal AC Voltage (50/60Hz)	Un	130V	240 V	240 V
Max. Continuous Operating Voltage (L-N)	Uc	150V	255 V	275 V
Lightning impulse current (10/350µs)	Iimp	50 kA		
Voltage protection level	Up	≤1,5 kV	≤2,5 kV	≤2,5 kV
Response time	tA	≤100ns		
Max. backup fuse		500 A gL/gG		
Temporary overvoltage- 120 min. (L-N)	UT	230 V	440 V	530 V
Follow current extinguishing capability (N-PE)	I _{fi}	50 kA _{RMS}		
Mechanical Features				
Operating temperature range	Ta	-40 C° to +80 C°		
Humidity	RH	5%...%90		
Tightening Torque	Mmax	4,5 Nm		
Cable Cross-sectional area (max.)		10-35 mm ² Solid / Stranded / Fleksible		
For mounting on		35 mm DIN Rail EN 60715		
Casing Material		Thermoplastic, UL 94 V-0		
Degree of protection		IP20		
Specific Features				
Modular		HAYIR		
Fault Indicators		Green for ok / Red for fault		
Remote Fault Signaling		YES		
Thermal Protection		YES		
Warranty		5 YEARS		



CIRCUIT DIAGRAM

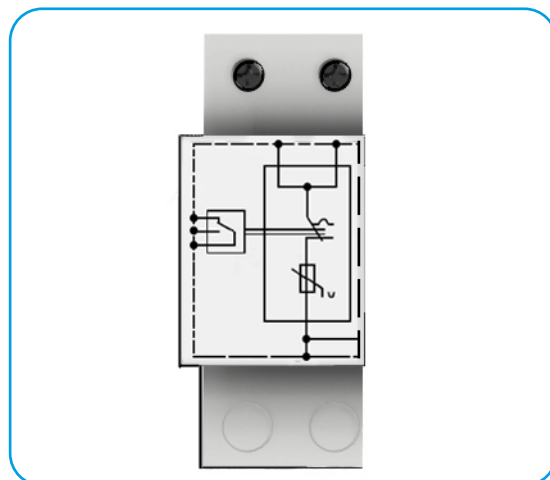

DIMENSIONS

Product Weight:	290 gr
Packaged Weight:	310 gr
Package Dimensions (ExBxY)	80x40x105 mm.

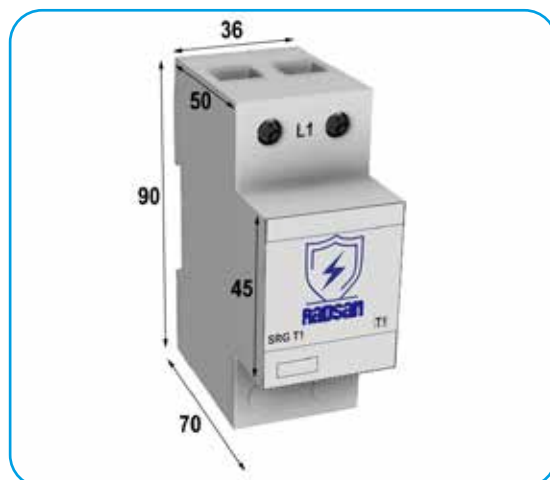



- Superior protection is provided by high performance varistors.
- Thanks to its compact design, SPD can be used easily even in the narrowest panels.
- Low maintenance cost thanks to modular design.
- Fault status can be monitored with the indicators on the SPD.
- With the dry contact output, the fault status can be monitored remotely.
- Designed and manufactured in Türkiye.
- 5 years of warranty
- **TUV certified**

**T2 Class SPD according to EN 61643-11.
Combination: 3+1, TT and TN-S Network**



SRG T2 3+1 150 | SRG T2 3+1 275 | SRG T2 3+1 320 | SRG T2 3+1 385

Electrical Features					
Nominal AC Voltage (50/60Hz)	Un	120 V	230 V	230 V	230 V
Max. Continuous Operating Voltage (L-N)	Uc	150 V	275 V	320 V	385 V
En Yüksek Sürekli Çalışma AC Gerilimi (N-PE)	Uc	255 V	255 V	255 V	255 V
Nominal discharge current (8/20µs)	In	20 kA			
Max. discharge current (8/20µs)	Imax	40 kA			
Voltage protection level (L-N)	Up	≤0,7 kV	≤1,3 kV	≤1,5 kV	≤1,8 kV
Voltage protection level (L-N) at 5 kA	Up	≤0,55 kV	≤1 kV	≤1,2 kV	≤1,4 kV
Voltage protection level (N-PE)	Up	≤1,5 kV	≤1,5 kV	≤1,5 kV	≤1,5 kV
Response time	tA	≤25ns / ≤100ns			
Max. backup fuse		125 A gL/gG			
TOV- 5s. (L-N)		175 V	335 V	335 V	335 V
Temporary overvoltage- 120 min. (L-N)	UT	235 V	440 V	440 V	440 V
Temporary overvoltage-200 ms (N-PE)	UT	1200 V			
Follow current extinguishing capability (N-PE)	Ifi	100 A _{RMS}			

Mechanical Features		
Operating temperature range	Ta	-40 C° to +80 C°
Humidity	RH	5%...%90
Tightening Torque	Mmax	4,5 Nm
Cable Cross-sectional area (max.)		35 mm ² Solid / Stranded / 25 mm ² Flexible
For mounting on		35 mm DIN Rail EN 60715
Casing Material		Thermoplastic, UL 94 V-0
Degree of protection		IP20

Specific Features		
Modular		YES
Fault Indicators		Green for ok / Red for fault
Remote Fault Signaling		YES
Thermal Protection		YES
Warranty		5 YEARS



CIRCUIT DIAGRAM

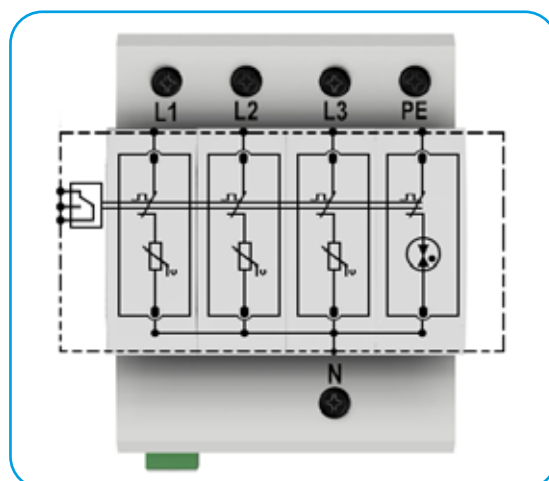

DIMENSIONS

Product Weight:	355 gr
Packaged Weight:	385 gr
Package Dimensions (ExBxY)	75x100x77 mm.

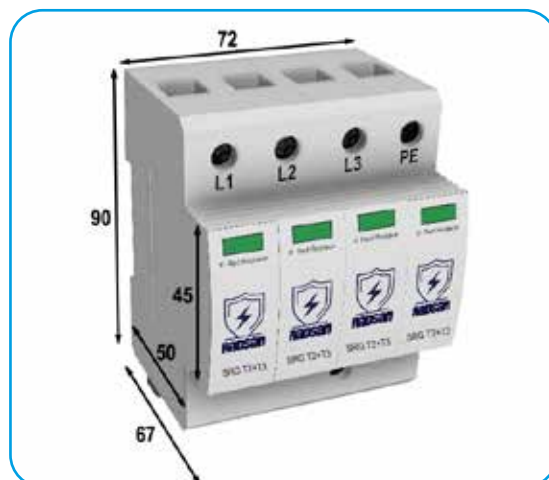

CONNECTION DIAGRAM

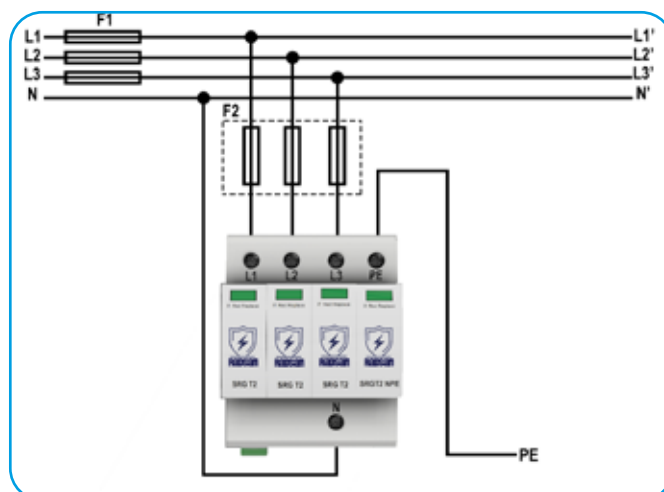
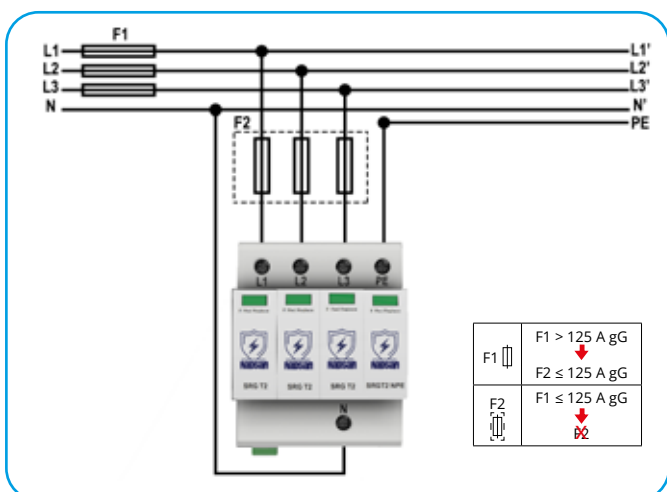



- Superior protection is provided by high performance varistors.
- Thanks to its compact design, SPD can be used easily even in the narrowest panels.
- Low maintenance cost thanks to modular design.
- Fault status can be monitored with the indicators on the SPD.
- With the dry contact output, the fault status can be monitored remotely.
- Designed and manufactured in Türkiye.
- 5 years of warranty
- **TUV certificated**



T2 Class SPD according to EN 61643-11.

		SRG T2 1+1 275	SRG T2 1+1 320	SRG T2 1+1 385
Electrical Features				
Nominal AC Voltage (50/60Hz)	Un	230 V	230 V	230 V
Max. Continuous Operating Voltage (L-N)	Uc	275 V	320 V	385 V
En Yüksek Sürekli Çalışma AC Gerilimi (N-PE)	Uc	255 V	255 V	255 V
Nominal discharge current (8/20µs)	In	20 kA		
Max. discharge current (8/20µs)	I _{max}	40 kA		
Voltage protection level (L-N)	Up	≤1,3 kV	≤1,5 kV	≤1,8 kV
Voltage protection level (L-N) at 5 kA	Up	≤1 kV	≤1,2 kV	≤1,4 kV
Voltage protection level (N-PE)	Up	≤1,5 kV	≤1,5 kV	≤1,5 kV
Response time	t _A	≤25ns / ≤100ns		
Max. backup fuse		125 A gL/gG		
TOV- 5s. (L-N)		335 V	335 V	335 V
Temporary overvoltage- 120 min. (L-N)	UT	440 V	440 V	440 V
Temporary overvoltage-200 ms (N-PE)	UT	1200 V		
Follow current extinguishing capability (N-PE)	I _{fi}	100 A _{RMS}		
Mechanical Features				
Operating temperature range	T _a	-40 C° to +80 C°		
Humidity	RH	5%...%90		
Tightening Torque	M _{max}	4,5 Nm		
Cable Cross-sectional area (max.)		35 mm ² Solid / Stranded / 25 mm ² Flexible		
For mounting on		35 mm DIN Rail EN 60715		
Casing Material		Thermoplastic, UL 94 V-0		
Degree of protection		IP20		
Specific Features				
Modular		YES		
Fault Indicators		Green for ok / Red for fault		
Remote Fault Signaling		YES		
Thermal Protection		YES		
Warranty		5 YEARS		



CIRCUIT DIAGRAM

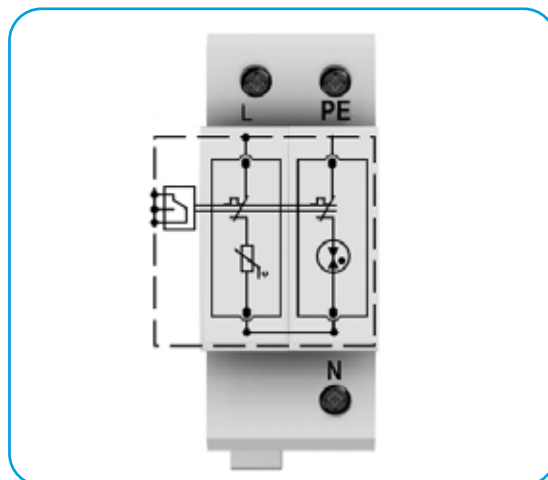

DIMENSIONS

Product Weight:	180 gr
Packaged Weight:	200 gr
Package Dimensions (ExBxY)	40x100x77 mm.



CONNECTION DIAGRAM

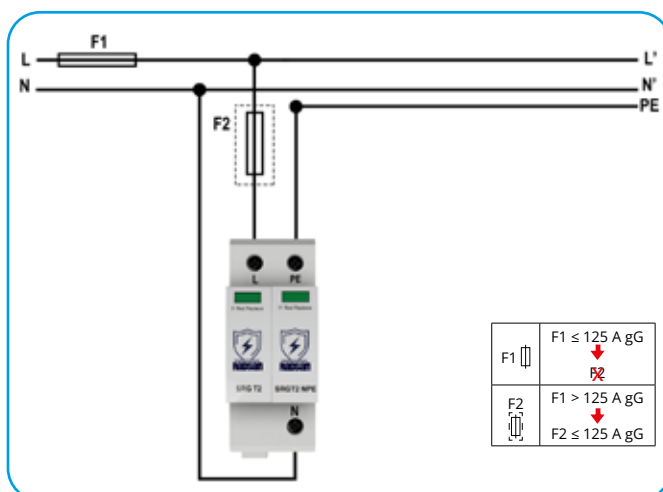



- Superior protection is provided by high performance varistors.
- Thanks to its compact design, SPD can be used easily even in the narrowest panels.
- Low maintenance cost thanks to modular design.
- Fault status can be monitored with the indicators on the SPD.
- With the dry contact output, the fault status can be monitored remotely.
- Designed and manufactured in Turkiye.
- 5 years of warranty
- **TUV certificated**



T2 Class SPD according to EN 61643-11.

		SRG T2 4P 150	SRG T2 4P 275	SRG T2 4P 320	SRG T2 4P 385
Electrical Features					
Nominal AC Voltage (50/60Hz)	Un	120V	230 V	230 V	230 V
Max. Continuous Operating Voltage (L-N)	Uc	150V	275 V	320 V	385 V
Nominal discharge current (8/20µs)	In	20 kA			
Max. discharge current (8/20µs)	I _{max}	40 kA			
Voltage protection level	Up	≤0,8 kV	≤1,3 kV	≤1,5 kV	≤1,8 kV
Voltage protection level at 5 kA	Up	≤0,6 kV	≤1 kV	≤1,2 kV	≤1,4 kV
Response time	t _A	≤25ns			
Max. backup fuse		125 A gL/gG			
TOV- 5s.		175 V	335 V	335 V	335 V
TOV- 120 min	UT	235 V	440 V	440 V	440 V
Mechanical Features					
Operating temperature range	T _a	-40 C° to +80 C°			
Humidity	RH	5%...%90			
Tightening Torque	M _{max}	4,5 Nm			
Cable Cross-sectional area (max.)		35 mm ² Solid / Stranded / 25 mm ² Flexible			
For mounting on		35 mm DIN Rail EN 60715			
Casing Material		Thermoplastic, UL 94 V-0			
Degree of protection		IP20			
Specific Features					
Modular		YES			
Fault Indicators		Green for ok / Red for fault			
Remote Fault Signaling		YES			
Thermal Protection		YES			
Warranty		5 YEARS			



CIRCUIT DIAGRAM

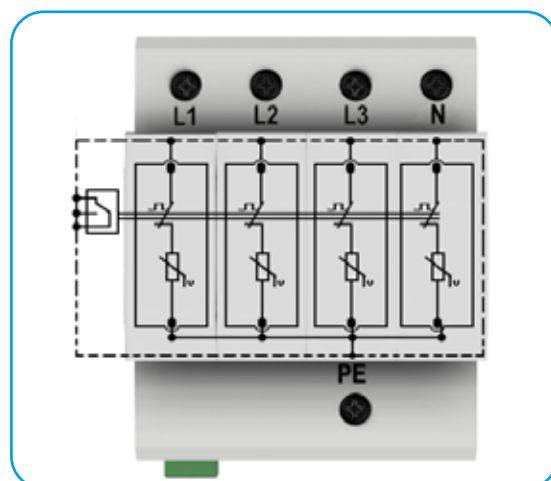

DIMENSIONS

Product Weight:	355 gr
Packaged Weight:	385 gr
Package Dimensions (ExBxY)	75x100x77 mm.

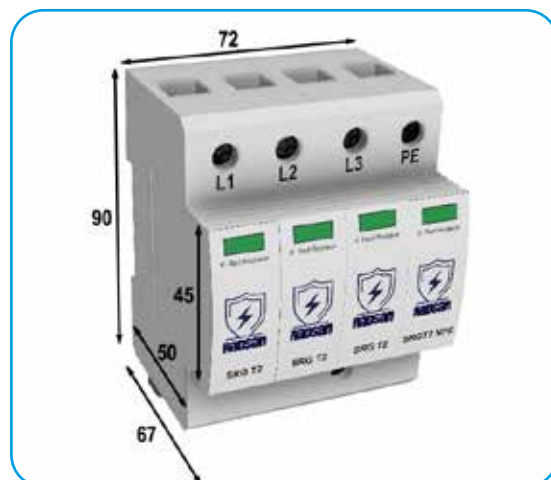

CONNECTION DIAGRAM

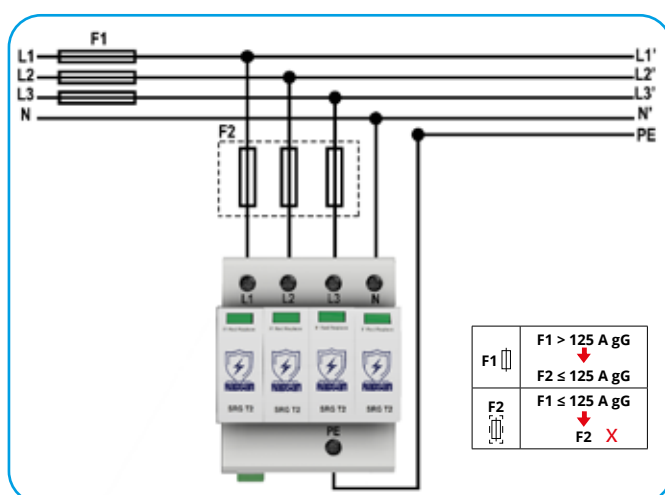



- Superior protection is provided by high performance varistors.
- Thanks to its compact design, SPD can be used easily even in the narrowest panels.
- Low maintenance cost thanks to modular design.
- Fault status can be monitored with the indicators on the SPD.
- With the dry contact output, the fault status can be monitored remotely.
- Designed and manufactured in Turkiye.
- 5 years of warranty
- **TUV certificated**



T2 Class SPD according to EN 61643-11.

		SRG T2 3P 150	SRG T2 3P 275	SRG T2 3P 320	SRG T2 3P 385
Electrical Features					
Nominal AC Voltage (50/60Hz)	Un	120V	230 V	230 V	230 V
Max. Continuous Operating Voltage (L-N)	Uc	150V	275 V	320 V	385 V
Nominal discharge current (8/20µs)	In	20 kA			
Max. discharge current (8/20µs)	I _{max}	40 kA			
Voltage protection level	Up	≤0,8 kV	≤1,3 kV	≤1,5 kV	≤1,8 kV
Voltage protection level at 5 kA	Up	≤0,6 kV	≤1 kV	≤1,2 kV	≤1,4 kV
Response time	t _A	≤25ns			
Max. backup fuse		125 A gL/gG			
TOV- 5s.		175 V	335 V	335 V	335 V
TOV- 120 min	UT	235 V	440 V	440 V	440 V
Mechanical Features					
Operating temperature range	T _a	-40 C° to +80 C°			
Humidity	RH	5%...%90			
Tightening Torque	M _{max}	4,5 Nm			
Cable Cross-sectional area (max.)		35 mm ² Solid / Stranded / 25 mm ² Flexible			
For mounting on		35 mm DIN Rail EN 60715			
Casing Material		Thermoplastic, UL 94 V-0			
Degree of protection		IP20			
Specific Features					
Modular		YES			
Fault Indicators		Green for ok / Red for fault			
Remote Fault Signaling		YES			
Thermal Protection		YES			
Warranty		5 YEARS			



CIRCUIT DIAGRAM

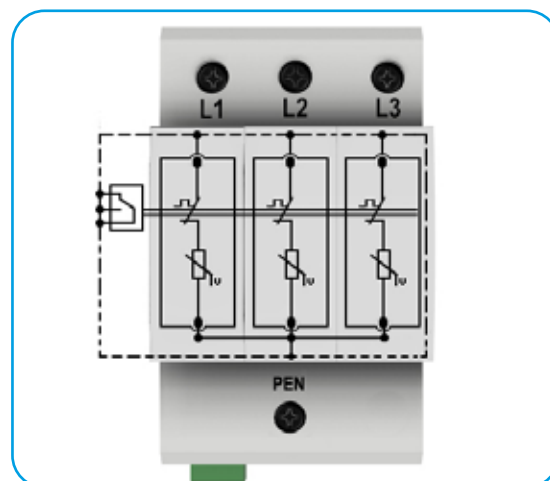

DIMENSIONS

Product Weight:	265 gr
Packaged Weight:	290 gr
Package Dimensions (ExBxY)	60x100x77 mm.



CONNECTION DIAGRAM

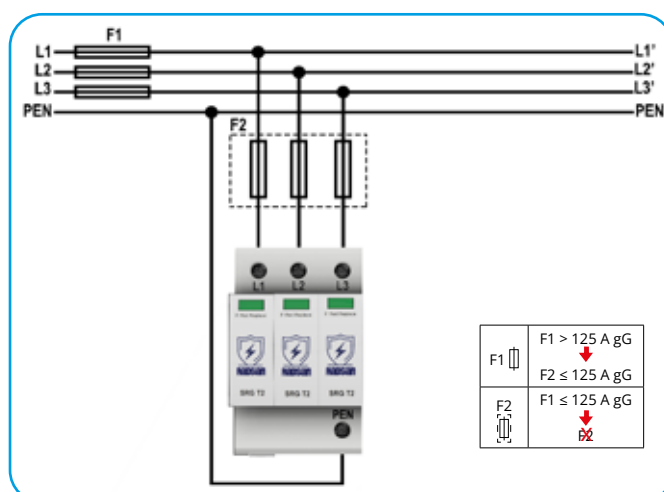



- Superior protection is provided by high performance varistors.
- Thanks to its compact design, SPD can be used easily even in the narrowest panels.
- Low maintenance cost thanks to modular design.
- Fault status can be monitored with the indicators on the SPD.
- With the dry contact output, the fault status can be monitored remotely.
- Designed and manufactured in Turkiye.
- 5 years of warranty
- **TUV certificated**



T2 Class SPD according to EN 61643-11.

		SRG T2 2P 150	SRG T2 2P 275	SRG T2 2P 320	SRG T2 2P 385
Electrical Features					
Nominal AC Voltage (50/60Hz)	Un	120V	230 V	230 V	230 V
Max. Continuous Operating Voltage (L-N)	Uc	150V	275 V	320 V	385 V
Nominal discharge current (8/20µs)	In	20 kA			
Max. discharge current (8/20µs)	I _{max}	40 kA			
Voltage protection level	Up	≤0,8 kV	≤1,3 kV	≤1,5 kV	≤1,8 kV
Voltage protection level at 5 kA	Up	≤0,6 kV	≤1 kV	≤1,2 kV	≤1,4 kV
Response time	t _A	≤25ns			
Max. backup fuse		125 A gL/gG			
TOV- 5s.		175 V	335 V	335 V	335 V
TOV- 120 min	UT	235 V	440 V	440 V	440 V
Mechanical Features					
Operating temperature range	T _a	-40 C° to +80 C°			
Humidity	RH	5%....%90			
Tightening Torque	M _{max}	4,5 Nm			
Cable Cross-sectional area (max.)		35 mm ² Solid / Stranded / 25 mm ² Flexible			
For mounting on		35 mm DIN Rail EN 60715			
Casing Material		Thermoplastic, UL 94 V-0			
Degree of protection		IP20			
Specific Features					
Modular		YES			
Fault Indicators		Green for ok / Red for fault			
Remote Fault Signaling		YES			
Thermal Protection		YES			
Warranty		5 YEARS			



CIRCUIT DIAGRAM

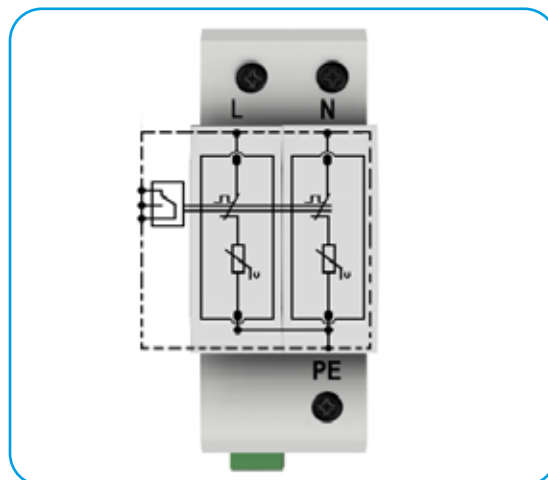

DIMENSIONS

Product Weight:	180 gr
Packaged Weight:	200 gr
Package Dimensions (ExBxY)	40x100x77 mm.



CONNECTION DIAGRAM

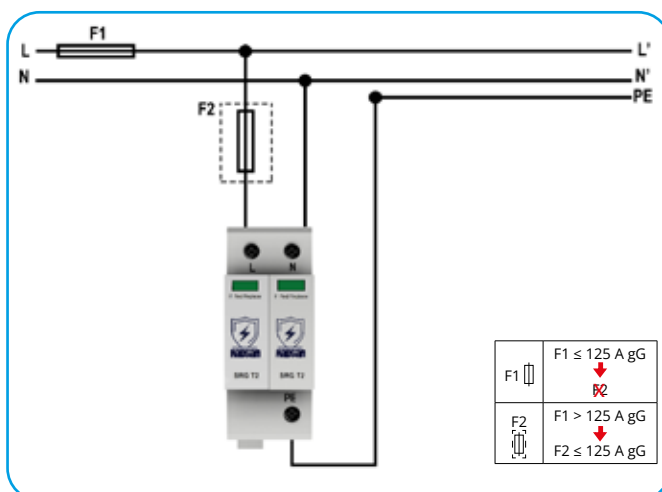



- Superior protection is provided by high performance varistors.
- Thanks to its compact design, SPD can be used easily even in the narrowest panels.
- Low maintenance cost thanks to modular design.
- Fault status can be monitored with the indicators on the SPD.
- With the dry contact output, the fault status can be monitored remotely.
- Designed and manufactured in Türkiye.
- 5 years of warranty
- **TUV certified**



T2 Class SPD according to EN 61643-11.

SRG T2 1P 48V SRG T2 1P 75V SRG T2 1P 150V SRG T2 1P 275V SRG T2 1P 320V SRG T2 1P 385V

Electrical Features							
		SRG T2 1P 48V	SRG T2 1P 75V	SRG T2 1P 150V	SRG T2 1P 275V	SRG T2 1P 320V	SRG T2 1P 385V
Nominal AC Voltage (50/60Hz)	Un	42 V	60 V	120V	230 V	230 V	230 V
Max. Continuous Operating Voltage (L-N)	Uc	48 V	75 V	150V	275 V	320 V	385 V
En Yüksek Sürekli Çalışma DC Gerilimi	Uc	60 V	100 V	200 V	350 V	420 V	500 V
Nominal discharge current (8/20µs)	In	20 kA					
Max. discharge current (8/20µs)	Imax	40 kA					
Voltage protection level	Up	≤0,4 kV	≤0,5 kV	≤0,8 kV	≤1,3 kV	≤1,5 kV	≤1,8 kV
Voltage protection level at 5 kA	Up	≤0,3 kV	≤0,35 kV	≤0,6 kV	≤1 kV	≤1,2 kV	≤1,4 kV
Max. backup fuse		125 A gL/gG					
Response time	tA	≤25ns					
TOV- 5s.	UT	70 V	90 V	175 V	335 V	335 V	335 V
TOV- 120 min	UT	90 V	115 V	230 V	440 V	440 V	440 V
Mechanical Features							
Operating temperature range	Ta	-40 C° to +80 C°					
Humidity	RH	5%....%90					
Tightening Torque	Mmax	4,5 Nm					
Cable Cross-sectional area (max.)		35 mm ² Solid / Stranded / 25 mm ² Flexible					
For mounting on		35 mm DIN Rail EN 60715					
Casing Material		Thermoplastic, UL 94 V-0					
Degree of protection		IP20					
Specific Features							
Modular		YES					
Fault Indicators		Green for ok / Red for fault					
Remote Fault Signaling		YES					
Thermal Protection		YES					
Warranty		5 YEARS					



CIRCUIT DIAGRAM

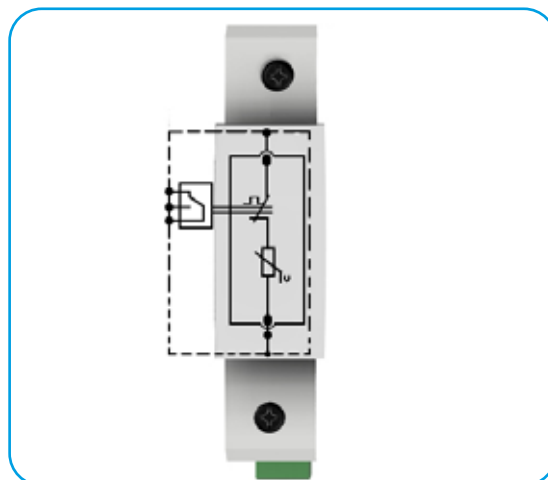

DIMENSIONS

Product Weight:	100 gr
Packaged Weight:	115 gr
Package Dimensions (ExBxY)	20x100x77 mm.





- Superior protection is provided by high performance varistors.
- Thanks to its compact design, SPD can be used easily even in the narrowest panels.
- Low maintenance cost thanks to modular design.
- Fault status can be monitored with the indicators on the SPD.
- With the dry contact output, the fault status can be monitored remotely.
- Designed and manufactured in Turkiye.
- 5 years of warranty

T2+3 Class SPD according to EN 61643-11.

Network Type	SRG T2+3 3+1 320		SRG T2+3 1+1 320		SRG T2+3 4+0 320		SRG T2+3 1+0 320	
	TT and TN-S		TT and TN-S		TN-S			
Electrical Features								
Nominal AC Voltage (50/60Hz)	Un	230 V/400 V		230 V/400 V		230 V/400 V		230 V/400 V
Max. Continuous Operating Voltage (L-N)	Uc	320 V		320 V		320 V		320 V
Nominal discharge current (8/20µs)	In	20 kA						
Max. discharge current (8/20µs)	I _{max}	40 kA						
Voltage protection level	Up	≤1,5 kV		≤1,5 kV		≤1,5 kV		≤1,5 kV
Kombine Darbe	Uoc	10 kV/5kA		10 kV/5kA		10 kV/5kA		10 kV/5kA
Max. backup fuse		125 A gL/gG						
Response time	t _A	≤25ns						
TOV- 5s.	U _T	337 V		337 V		337 V		337 V
TOV- 120 min	U _T	442 V		442 V		442 V		442 V
Mechanical Features								
Operating temperature range	T _a	-40 C° to +80 C°						
Humidity	RH	5%...%90						
Tightening Torque	M _{max}	4,5 Nm						
Cable Cross-sectional area (max.)		35 mm ² Solid / Stranded / 25 mm ² Flexible						
For mounting on		35 mm DIN Rail EN 60715						
Casing Material		Thermoplastic, UL 94 V-0						
Degree of protection		IP20						
Specific Features								
Modular		YES						
Fault Indicators		Green for ok / Red for fault						
Remote Fault Signaling		YES						
Thermal Protection		YES						
Warranty		5 YEARS						



CIRCUIT DIAGRAM

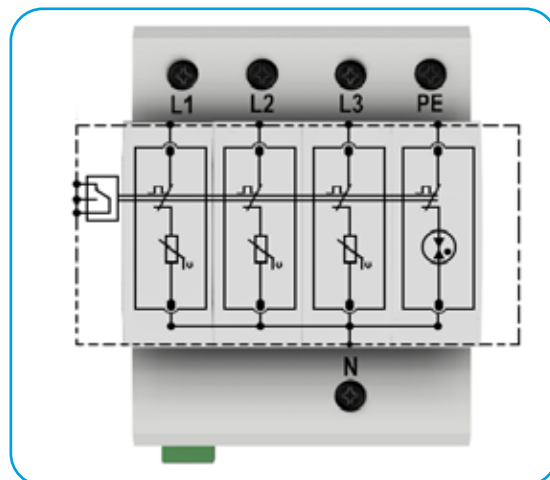

DIMENSIONS

Product Weight:	355 gr
Packaged Weight:	385 gr
Package Dimensions (ExBxY)	75x100x77 mm.

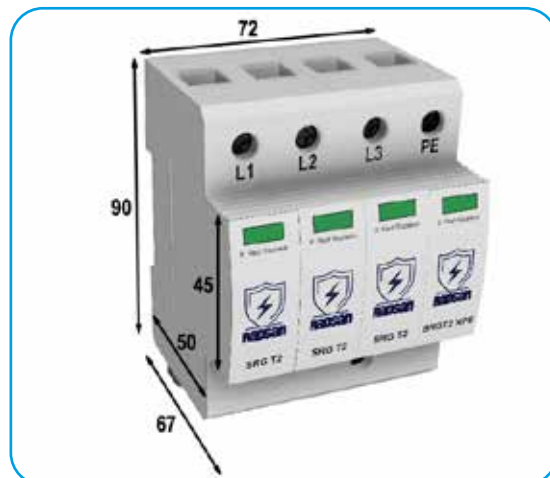

CONNECTION DIAGRAM

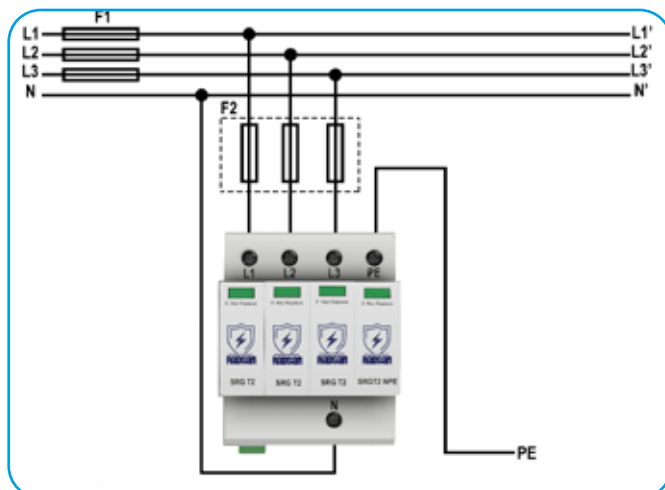
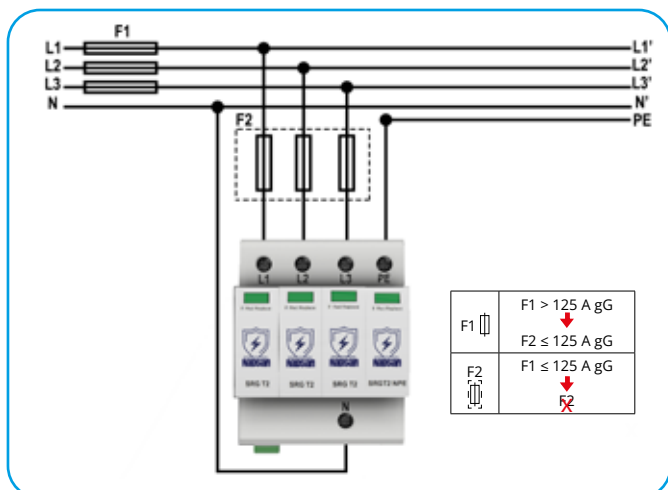



- Superior protection is provided by high performance varistors.
- Thanks to its compact design, SPD can be used easily even in the narrowest panels.
- Fault status can be monitored with the indicators on the SPD.
- With the dry contact output, the fault status can be monitored remotely.
- Designed and manufactured in Türkiye.
- 5 years of warranty

T3 Class SPD according to EN 61643-11.

		SRG T3 30	SRG T3 75	SRG T3 150	SRG T3 275
Electrical Features					
Nominal AC Voltage (50/60Hz)	Un	24 V	60 V	120 V	230 V
Max. Continuous Operating Voltage (L-N)	Uc	30 V	75 V	150 V	275 V
Max. Continuous Operating DC Voltage	Uc	38 V	100 V	--	--
Nominal discharge current (8/20µs)	In	10 kA			
Kombine Darbe	Uoc	10 kV			
Voltage protection level	Up	≤0,7 kV	≤0,8 kV	≤0,9 kV	≤1,3 kV
Response time	tA	≤25ns			
Mechanical Features					
Operating temperature range	Ta	-40 C° to +80 C°			
Humidity	RH	5%...%90			
Tightening Torque	Mmax	4,5 Nm			
Cable Cross-sectional area (max.)		35 mm ² Solid / Stranded / 25 mm ² Flexible			
For mounting on		35 mm DIN Rail EN 60715			
Casing Material		Thermoplastic, UL 94 V-0			
Degree of protection		IP20			
Specific Features					
Modular		HAYIR			
Fault Indicators		Green for ok / Red for fault			
Remote Fault Signaling		HAYIR			
Thermal Protection		YES			
Warranty		5 YEARS			



CIRCUIT DIAGRAM

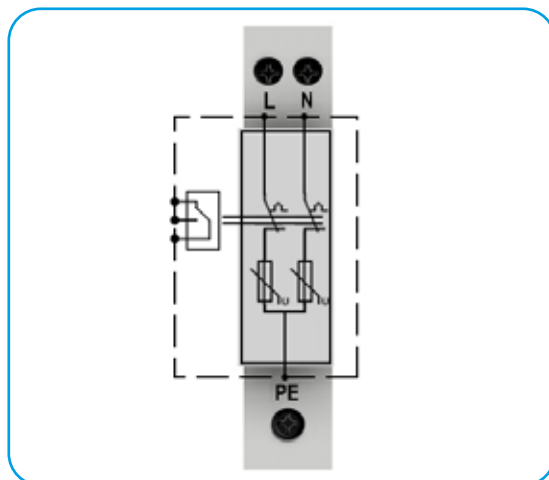

DIMENSIONS

Product Weight:	93 gr
Packaged Weight:	100 gr
Package Dimensions (ExBxY)	75x20x95 mm.

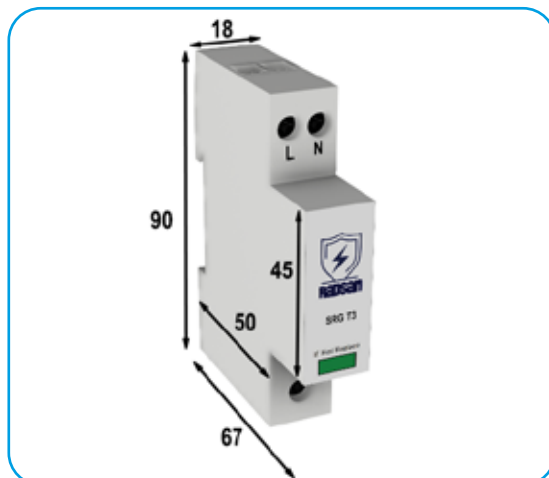

CONNECTION DIAGRAM

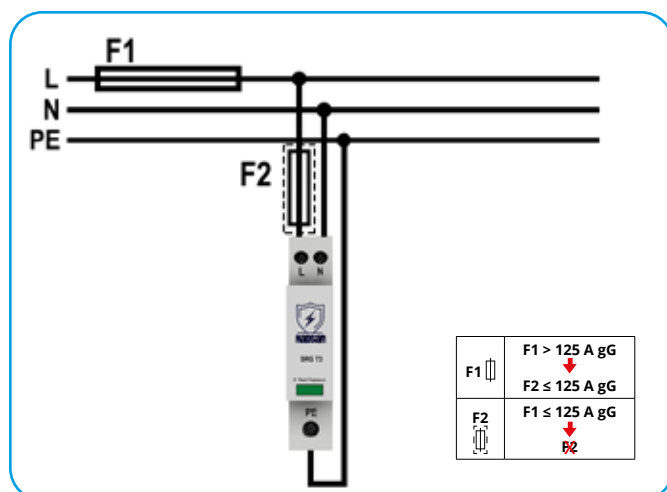



- Developed for DC Power systems.
- High level protection is provided by hybrid technology in which varistors and GDT are used together.
- Thanks to its compact design, SPD can be used easily even in the narrowest panels.
- Low maintenance cost thanks to modular design.
- Fault status can be monitored with the indicators on the SPD.
- With the dry contact output, the fault status can be monitored remotely.

A.G. according to EN 61643-11 standard Surge arrester class is DC.

SRG-20DP/24V RS

Electrical Features		
Nominal DC Gerilimi	Un	24 V DC
Highest Continuous Operating DC Voltage	Uc	36 V DC
Nominal discharge current (8/20µs)	In	20 kA
Max. discharge current (8/20µs)	Imax	40 kA
Voltage protection level (L-N)	Up	300 V
Combined Blow	Uoc	10 kV
Leakage Current	Ipe	≤0.1mA
Response time	tA	≤25ns
Mechanical Features		
Operating temperature range	Ta	-40 C° to +80 C°
Conductor Cross Section		2.5 - 16 mm ²
For mounting on		35 mm DIN Rail
Casing Material		Thermoplastic, UL 94 V-0
Degree of protection		IP20
Specific Features		
Modular		YES
Fault Indicators		Green for ok / Red for fault
Remote Fault Signaling		YES
Thermal Protection		YES
Warranty		2 YEARS



CIRCUIT DIAGRAM

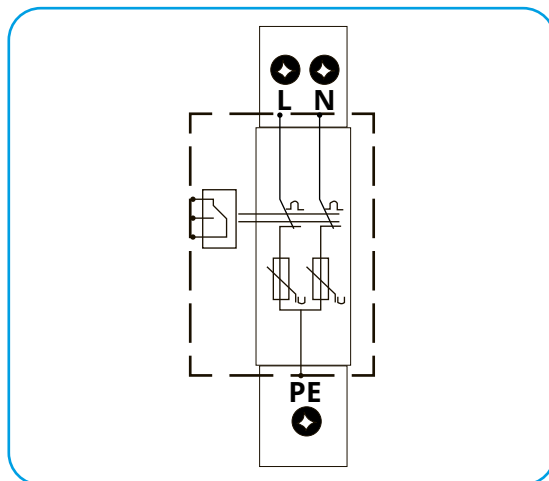

DIMENSIONS

Product Weight:	120 gr
Packaged Weight:	130 gr
Package Dimensions (ExBxY)	75x20x95

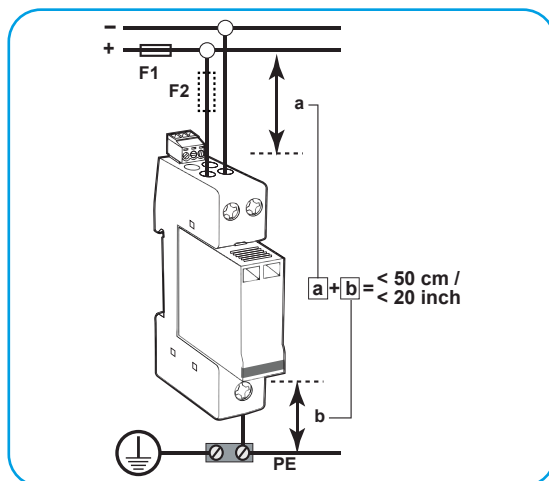

CONNECTION DIAGRAM

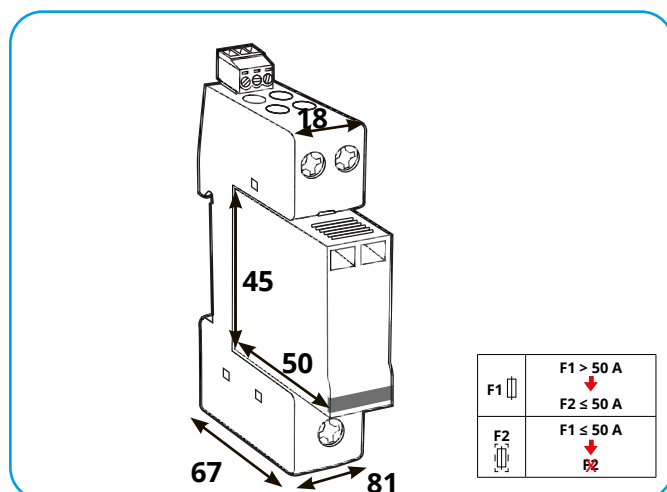



- Developed for DC Power systems.
- High level protection is provided by hybrid technology in which varistors and GDT are used together.
- Thanks to its compact design, SPD can be used easily even in the narrowest panels.
- Low maintenance cost thanks to modular design.
- Fault status can be monitored with the indicators on the SPD.
- With the dry contact output, the fault status can be monitored remotely.

A.G. according to EN 61643-11 standard Surge arrester class is DC.

SRG-40DP/75V RS

Electrical Features		
Nominal DC Gerilimi	Un	75 V DC
Highest Continuous Operating DC Voltage	Uc	100 V DC
Nominal discharge current (8/20µs)	In	20 kA
Max. discharge current (8/20µs)	Imax	40 kA
Voltage protection level (L-N)	Up	≤600V
Combined Blow	Uoc	10 kV
Leakage Current	Ipe	≤0.1mA
Front Fuse (Maximum)		125 gG
Response time	tA	≤25ns
Mechanical Features		
Operating temperature range	Ta	-40 C° to +80 C°
Conductor Cross Section		2.5 - 16 mm ²
For mounting on		35 mm DIN Rail
Casing Material		Thermoplastic, UL 94 V-0
Degree of protection		IP20
Specific Features		
Modular		YES
Fault Indicators		Green for ok / Red for fault
Remote Fault Signaling		YES
Thermal Protection		YES
Warranty		2 YEARS



CIRCUIT DIAGRAM

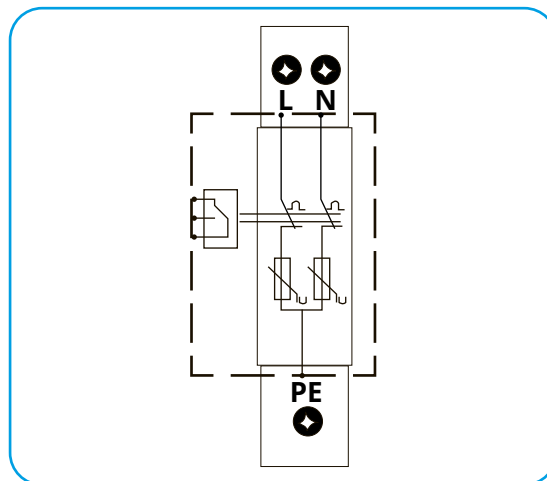

DIMENSIONS

Product Weight:	120 gr
Packaged Weight:	130 gr
Package Dimensions (ExBxY)	75x20x95

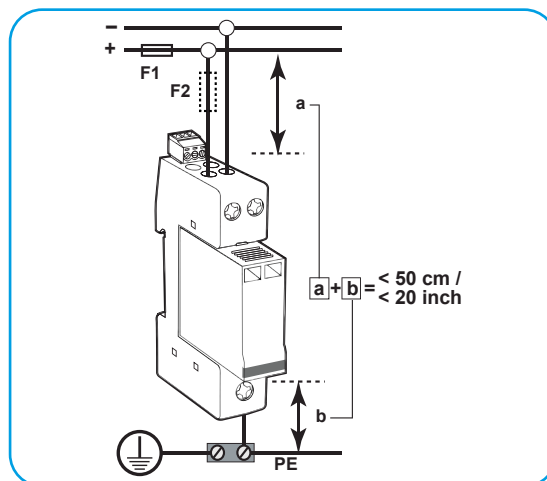

CONNECTION DIAGRAM

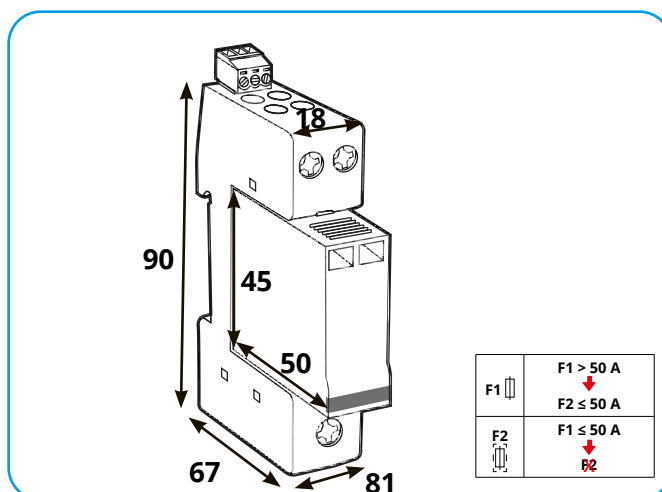



- Developed for DC Power systems.
- High level protection is provided by hybrid technology in which varistors and GDT are used together.
- Thanks to its compact design, SPD can be used easily even in the narrowest panels.
- Low maintenance cost thanks to modular design.
- Fault status can be monitored with the indicators on the SPD.
- With the dry contact output, the fault status can be monitored remotely.

A.G. according to EN 61643-11 standard Surge arrester class is DC.

SRG-40DP/75V RS

Electrical Features		
Nominal DC Gerilimi	Un	110 V DC
Highest Continuous Operating DC Voltage	Uc	150 V DC
Nominal discharge current (8/20µs)	In	20 kA
Max. discharge current (8/20µs)	Imax	40 kA
Voltage protection level (L-N)	Up	≤600V
Combined Blow	Uoc	10 kV
Leakage Current	Ipe	≤0.1mA
Front Fuse (Maximum)		125 gG
Response time	tA	≤25ns
Mechanical Features		
Operating temperature range	Ta	-40 C° to +80 C°
Conductor Cross Section		2.5 - 16 mm ²
For mounting on		35 mm DIN Rail
Casing Material		Thermoplastic, UL 94 V-0
Degree of protection		IP20
Specific Features		
Modular		YES
Fault Indicators		Green for ok / Red for fault
Remote Fault Signaling		YES
Thermal Protection		YES
Warranty		2 YEARS



CIRCUIT DIAGRAM

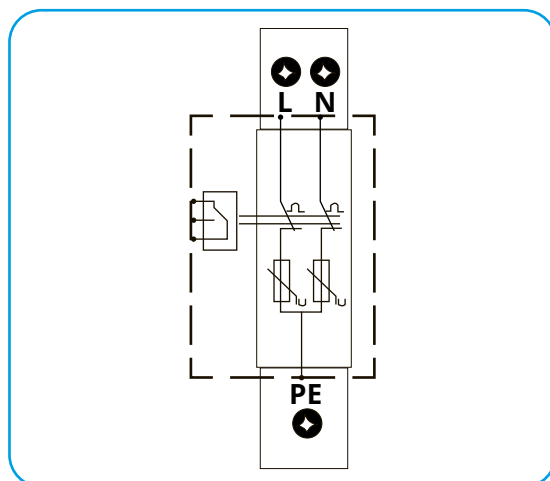

DIMENSIONS

Product Weight:	120 gr
Packaged Weight:	130 gr
Package Dimensions (ExBxY)	75x20x95

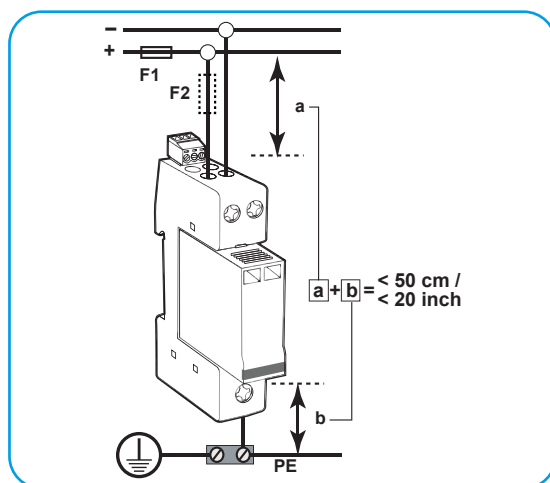

CONNECTION DIAGRAM

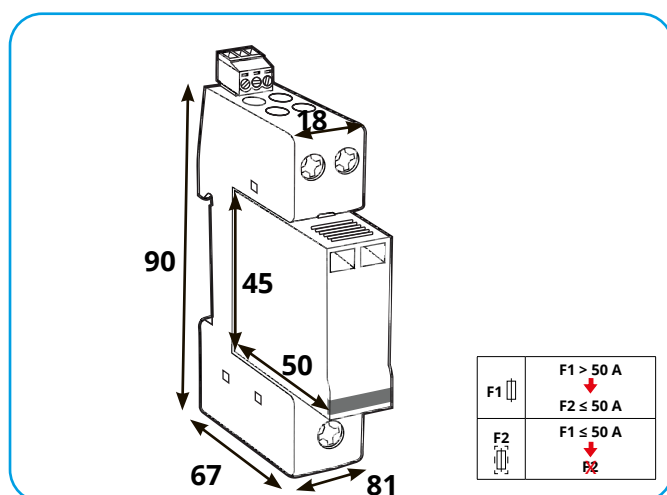



- High level protection is provided by hybrid technology in which varistors and GDT are used together.
- Thanks to its compact design, SPD can be used easily even in the narrowest panels
- Low maintenance cost thanks to modular design.
- Fault status can be monitored with the indicators on the SPD.
- With the dry contact output, the fault status can be monitored remotely.
- Designed and manufactured in Turkiye.
- 5 years of warranty

SRG PV T1 1200

Electrical Features

Nominal DC Voltage	Un	1000 V
Highest Continuous Operating DC Voltage	U _{CPV}	1200 V
Impulse Current per Pole	I _{imp}	5 kA
Nominal discharge current (8/20 μ s)	I _n	20 kA
Max. discharge current (8/20 μ s)	I _{max}	50 kA
Voltage protection level	Up	≤ 4 kV
Residual Current	IPE	<0.1mA
Following Current	I _{fi}	None
Max. backup fuse		125 A gL
Response time	t _A	≤ 25 ns

Mechanical Features

Operating temperature range	T _a	-40 C° to +80 C°
Humidity	RH	5%...%90
Tightening Torque	M _{max}	4,5 Nm
Cable Cross-sectional area (max.)		35 mm ² Solid / Stranded / 25 mm ² Flexible
For mounting on		35 mm DIN Rail EN 60715
Casing Material		Thermoplastic, UL 94 V-0
Degree of protection		IP20

Specific Features

Modular		YES
Fault Indicators		Green for ok / Red for fault
Remote Fault Signaling		YES
Thermal Protection		YES
Warranty		5 YEARS



CIRCUIT DIAGRAM

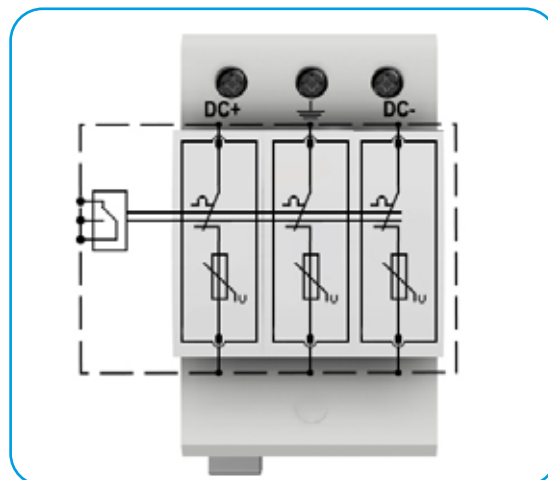

DIMENSIONS

Product Weight:	350 gr
Packaged Weight:	370 gr
Package Dimensions (ExBxY)	60x100x85 mm

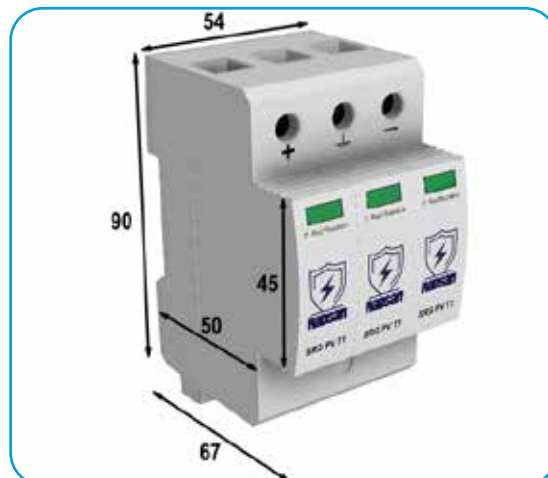

CONNECTION DIAGRAM

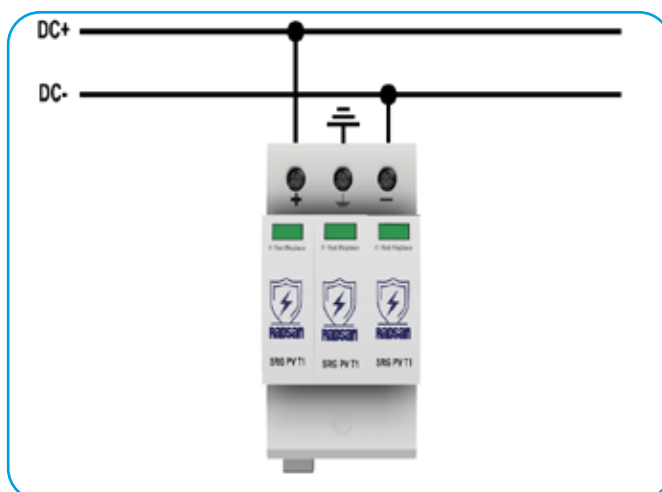



- High level protection is provided by hybrid technology in which varistors and GDT are used together.
- Thanks to its compact design, SPD can be used easily even in the narrowest panels
- Low maintenance cost thanks to modular design.
- Fault status can be monitored with the indicators on the SPD.
- With the dry contact output, the fault status can be monitored remotely.
- Designed and manufactured in Türkiye.
- 5 years of warranty

SRG PV T2 1000

Electrical Features

Highest Continuous Operating DC Voltage	U_{CPV}	1000 V
Nominal discharge current (8/20 μ s)	I_n	20 kA
Max. discharge current (8/20 μ s)	I_{max}	40 kA
Voltage protection level	U_p	≤ 4 kV
Short Circuit Resistance	I_{scpv}	1000 A
Max. backup fuse		125 A gL
Response time	t_A	≤ 25 ns

Mechanical Features

Operating temperature range	T_a	-40 C° to +80 C°
Humidity	RH	5%...%90
Tightening Torque	M_{max}	4,5 Nm
Cable Cross-sectional area (max.)		35 mm ² Solid / Stranded / 25 mm ² Flexible
For mounting on		35 mm DIN Rail EN 60715
Casing Material		Thermoplastic, UL 94 V-0
Degree of protection		IP20

Specific Features

Modular		YES
Fault Indicators		Green for ok / Red for fault
Remote Fault Signaling		YES
Thermal Protection		YES
Warranty		5 YEARS



CIRCUIT DIAGRAM

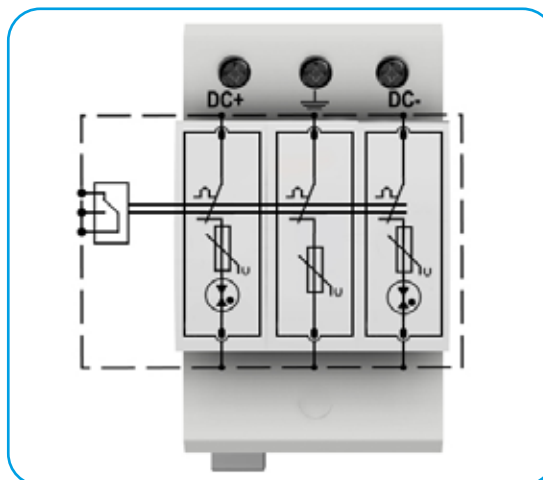

DIMENSIONS

Product Weight:	300 gr
Packaged Weight:	320 gr
Package Dimensions (ExBxY)	60x100x85 mm



CONNECTION DIAGRAM

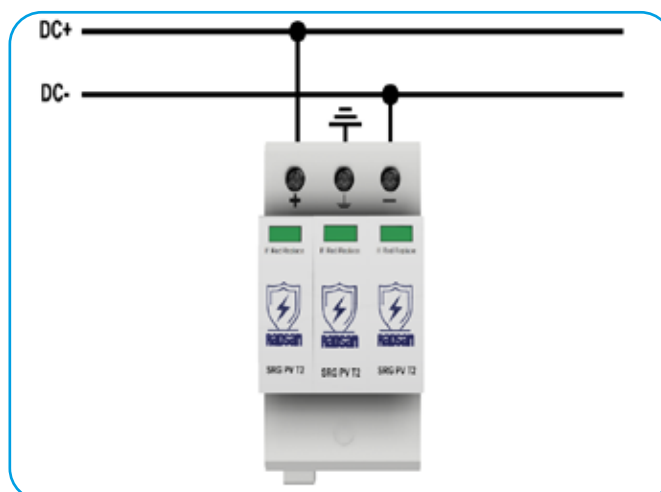



- High level protection is provided by hybrid technology in which varistors and GDT are used together.
- Thanks to its compact design, SPD can be used easily even in the narrowest panels
- Low maintenance cost thanks to modular design.
- Fault status can be monitored with the indicators on the SPD.
- With the dry contact output, the fault status can be monitored remotely.
- Designed and manufactured in Turkiye.
- 5 years of warranty

A.G. according to EN 61643-11 standard Surge arrester class is PV.

SRG T1+2 600 RS

Electrical Features		
Maximum Continuous Operation A.C. Income	Uc	600V
Lightning impulse current (10/350µs)	Iimp	12.5kA
Nominal discharge current (8/20µs)	In	20kA
Max. discharge current (8/20µs)	I _{max}	100kA
Voltage protection level	Up	≤3.0 kV
Specific Energy	W/R	39kJ/Ω
Charge	Q	6.25As
Short Circuit Withstand Capacity	I _{SSCCR}	25kA
Maximum Front Fuse		125A gG
Leakage Current	I _{PE}	<1mA
Response time	t _A	≤25ns
Mechanical Features		
Operating temperature range	Ta	-40 C° to +80 C°
Humidity	RH	5%....%90
Tightening Torque	M _{max}	4,5 Nm
Cable Cross-sectional area (max.)		35 mm ² Solid / Stranded / 25 mm ² Flexible
For mounting on		35 mm DIN Rail EN 60715
Casing Material		Thermoplastic, UL 94 V-0
Degree of protection		IP20
Specific Features		
Modular		YES
Fault Indicators		Green for ok / Red for fault
Remote Fault Signaling		YES
Thermal Protection		YES
Warranty		5 YEARS



CIRCUIT DIAGRAM

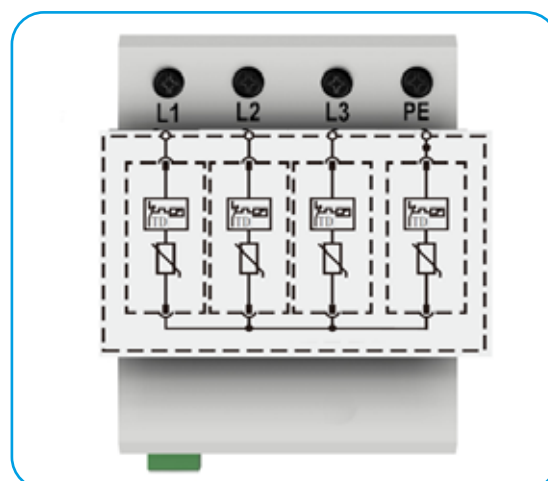

DIMENSIONS

Product Weight:	355 gr
Packaged Weight:	385 gr
Package Dimensions (ExBxY)	75x100x77 mm.

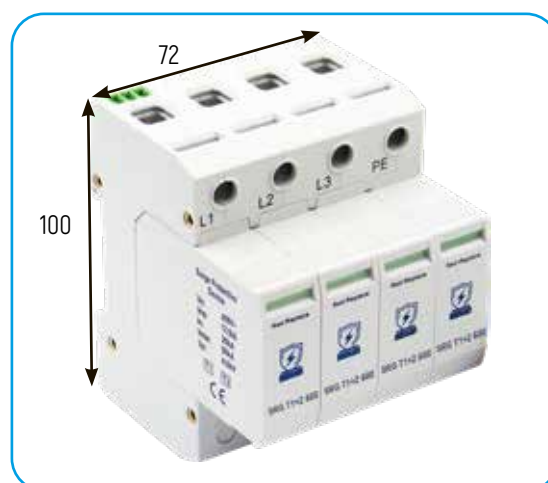

CONNECTION DIAGRAM

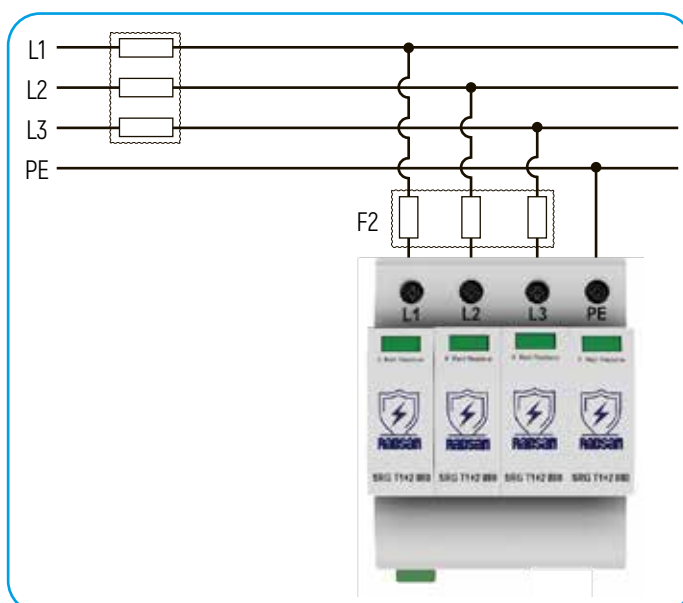



- High level protection is provided by hybrid technology in which varistors and GDT are used together.
- Thanks to its compact design, SPD can be used easily even in the narrowest panels
- Low maintenance cost thanks to modular design.
- Fault status can be monitored with the indicators on the SPD.
- With the dry contact output, the fault status can be monitored remotely.
- Designed and manufactured in Turkiye.
- 5 years of warranty

A.G. according to EN 61643-11 standard Surge arrester class is PV.

SRG T1+2 1000 RS

Electrical Features		
Maximum Continuous Operation A.C. Income	Uc	1000V
Lightning impulse current (10/350µs)	Iimp	12.5kA
Nominal discharge current (8/20µs)	In	20kA
Max. discharge current (8/20µs)	I _{max}	50kA
Voltage protection level	Up	≤4.0 kV
Specific Energy	W/R	39kJ/Ω
Charge	Q	6.25As
Short Circuit Withstand Capacity	I _{SSCCR}	25kA
Maximum Front Fuse		125A gG
Leakage Current	I _{PE}	<1mA
Response time	t _A	≤25ns
Mechanical Features		
Operating temperature range	Ta	-40 C° to +80 C°
Humidity	RH	5%...%90
Tightening Torque	M _{max}	4,5 Nm
Cable Cross-sectional area (max.)		35 mm ² Solid / Stranded / 25 mm ² Flexible
For mounting on		35 mm DIN Rail EN 60715
Casing Material		Thermoplastic, UL 94 V-0
Degree of protection		IP20
Specific Features		
Modular		YES
Fault Indicators		Green for ok / Red for fault
Remote Fault Signaling		YES
Thermal Protection		YES
Warranty		5 YEARS



CIRCUIT DIAGRAM

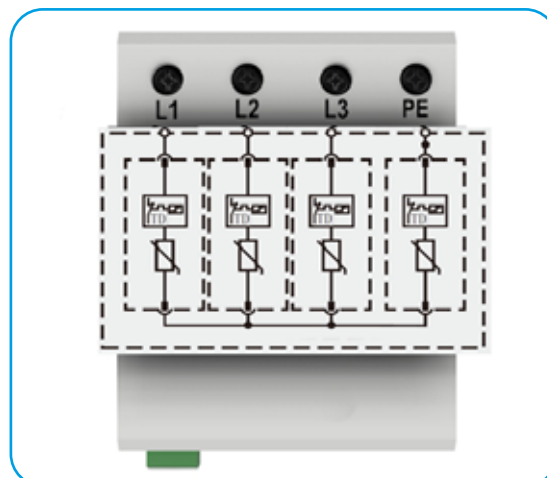

DIMENSIONS

Product Weight:	355 gr
Packaged Weight:	385 gr
Package Dimensions (ExBxY)	75x100x77 mm.

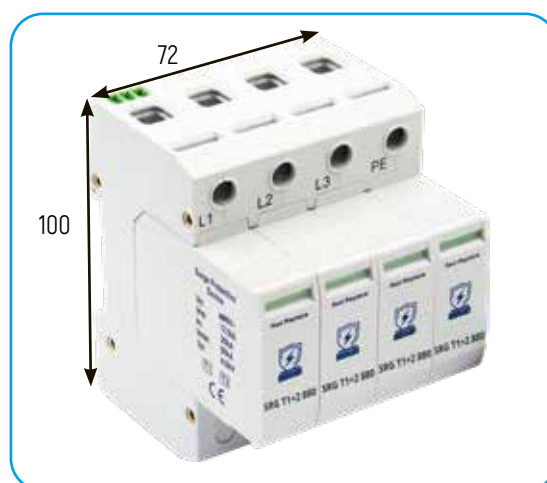

CONNECTION DIAGRAM

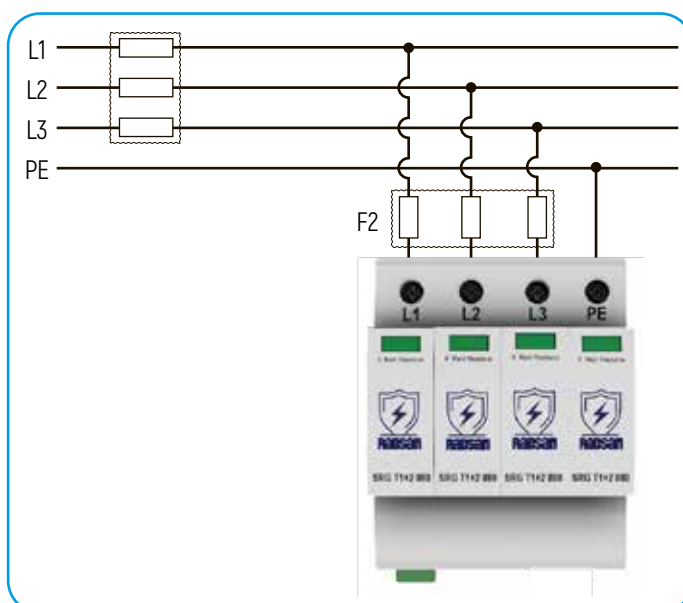



Superior protection is provided with GDT technology.

Thanks to its compact design, SPD can be used easily even in the narrowest panels.

Low maintenance cost thanks to modular design.

Designed and manufactured in Turkiye.

5 years of warranty

It is classified according to the EN 61643-21 standard.

		SRG PI 6	SRG PI 12	SRG PI 24	SRG PI 48
Electrical Features					
Nominal AC Voltage (50/60Hz)	Un	6 V	12 V	24 V	48 V
Max. Continuous Operating Voltage (L-N)	Uc	5 V	11 V	20 V	40 V
Maximum Continuous Operating DC Voltage	Uc	8 V	15 V	30 V	56 V
Nominal Current	I_L	0,4 A			
Nominal discharge current (8/20 μ s)	I_n	5 kA			
Voltage protection level (L-L)	Up	≤ 30 V	≤ 40 V	≤ 60 V	≤ 130 V
Voltage protection level (L-PG)	Up	≤ 600 V	≤ 600 V	≤ 600 V	≤ 600 V
Response time (L-L)	tA	≤ 1 ns			
Response time (L-PG)	tA	≤ 100 ns			
Bandwidth	Up	10 Mbps			
Insertion Loss	tA	$\leq 0,3$ dB			
Mechanical Features					
Operating temperature range	Ta	-40 C° to +80 C°			
Humidity	RH	5%...%90			
Tightening Torque	Mmax	4,5 Nm			
Cable Cross-sectional area (max.)		35 mm ² Solid / Stranded / 25 mm ² Flexible			
For mounting on		35 mm DIN Rail EN 60715			
Casing Material		Thermoplastic, UL 94 V-0			
Degree of protection		IP40			
Modular		YES			

DIMENSIONS

Product Weight:	65 gr
Packaged Weight:	75 gr
Package Dimensions (ExBxY)	20x70x95 mm.

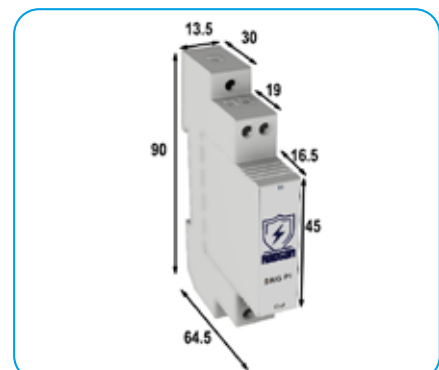



Superior protection is provided with GDT technology.

Thanks to its compact design, SPD can be used easily even in the narrowest panels.

Designed and manufactured in Turkiye.

5 years of warranty

Classified according to EN 61643-21 standard.

SRG-POE

Electrical Features

Nominal Gerilim	Un	48 V
Maximum Continuous Operating DC Voltage	Uc	56 V
Nominal Current	I _L	1 A
C2 Nominal discharge current (8/20µs) line-PG	I _n	10 kA
Voltage protection level (L-L)	Up	≤30 V
Voltage protection level (L-PG)	Up	≤600 V
Response time (L-L)	tA	≤1 ns
Response time (L-PG)	tA	≤100 ns
Bandwidth		1 Gbps
Insertion Loss		≤0,3 dB
Entry - Exit		RJ-45, PoE

Mechanical Features

Operating temperature range	Ta	-40 C° to +80 C°
Humidity	RH	5%...%90
Casing Material		Aluminium Alloy
Degree of protection		IP40

DIMENSIONS

Product Weight:	100 gr
Packaged Weight:	111.5 gr
Package Dimensions (ExBxY)	53x33x53mm





Superior protection is provided with GDT technology.
Thanks to its compact design, SPD can be used easily even in the narrowest panels. Designed and manufactured in Türkiye.
5 years of warranty

EN 61643-21 standardına göre sınıflandırılmıştır.

SRG-RJ45

Electrical Features

Nominal Voltage	Un	6 V
Maximum Continuous Operating DC Voltage	Uc	6 V
Max. Continuous Operating Voltage (L-N)	Uc	4 V
Nominal Current	IL	0,5 A
C2 Nominal discharge current (8/20µs) line-PG	In	5 kA
Voltage protection level (L-L)	Up	≤30 V
Voltage protection level (L-PG)	Up	≤500 V
Response time (L-L)	tA	≤1 ns
Response time (L-PG)	tA	≤100 ns
Bandwidth		300 Mbps
Insertion Loss		≤0,3 dB
Entry - Exit		RJ-45, 8 line

Mechanical Features

Operating temperature range	Ta	-40 C° to +80 C°
Humidity	RH	5%...%90
Casing Material		Aluminium Alloy
Degree of protection		IP40

DIMENSIONS

Product Weight:	76 gr
Packaged Weight:	88 gr
Package Dimensions (Ex-BxY)	35x105x60 mm.





GDT teknolojisi ile üstün koruma sağlar.

Thanks to its compact design, SPD can be used easily even in the narrowest panels. Designed and manufactured in Türkiye.

5 years of warranty

EN 61643-21 standardına göre sınıflandırılmıştır.

		SRG BNC	SRG BNC.H
Electrical Features			
Nominal Voltage	Un	5 V	-
Maximum Continuous Operating DC Voltage	Uc	6 V	180 V
Max. Continuous Operating Voltage (L-N)	Uc	4 V	130 V
Nominal Current	IL	0,5 A	20 A
C2 Nominal discharge current (8/20µs) line-shield	In	5 kA	-
C2 Nominal discharge current (8/20µs) shield-PG	In	10 kA	-
C2 Nominal discharge current (8/20µs) line-shield/PG		-	10 kA
Voltage protection level (L-shield)	Up	≤30 V	-
Voltage protection level (shield-PG)	Up	≤500 V	-
Voltage protection level (line-shield/PG)		-	≤800 V
Response time (L-shield))	tA	≤1 ns	-
Response time (shield-PG)	tA	≤100 ns	-
Response time (line-shield/PG)	tA	-	≤100 ns
Bandwidth			10 Mbps
Insertion Loss			≤0,3 dB
Empedans			50 Ω
Entry - Exit			BNC
Mechanical Features			
Operating temperature range	Ta	-40 C° to +80 C°	
Humidity	RH	5%...%90	
Casing Material		Aluminium Alloy	
Degree of protection		IP40	

DIMENSIONS

Product Weight:	66 gr
Packaged Weight:	80 gr
Package Dimensions (ExBxY)	40x30x90 mm.





High level protection is provided by hybrid technology in which varistors and GDT are used together.

Thanks to its compact design, SPD can be used easily even in the narrowest panels.

Designed and manufactured in Türkiye.

5 years of warranty

It is classified according to the EN 61643-21 standard.

SRG LSA

Electrical Features

Nominal Voltage	Un	180 V
Maximum Continuous Operating DC Voltage	Uc	180 V
Max. Continuous Operating Voltage (L-N)	Uc	127 V
Nominal Current	IL	0,4 A
C2 Nominal discharge current (8/20µs) line-shield	In	5 kA
C2 Nominal discharge current (8/20µs) shield-PG	In	10 kA
C2 Nominal discharge current (8/20µs) line-shield/PG		2,5 kA
Voltage protection level (L-shield)	Up	5 kA
Voltage protection level (shield-PG)	Up	≤500 V
Voltage protection level (line-shield/PG)		≤500 V

Mechanical Features

Operating temperature range	Ta	-40 C° to +80 C°
Humidity	RH	5%...%90
Casing Material		Polyamide
Degree of protection		IP40

DIMENSIONS

Product Weight:	65 gr
Packaged Weight:	75 gr
Package Dimensions (ExBxY)	25x120x40 mm.

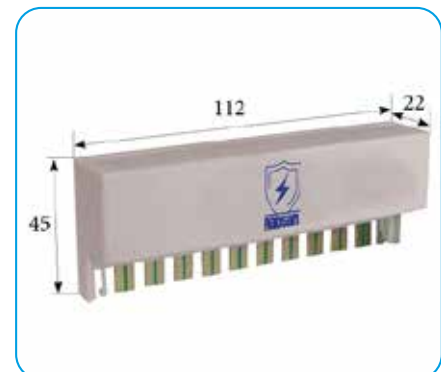



High level protection is provided by hybrid technology in which varistors and GDT are used together.

Thanks to its compact design, SPD can be used easily even in the narrowest panels. Designed and manufactured in Türkiye.

5 years of warranty

It is classified according to the EN 61643-21 standard.

SRG SUBD 9 SRG SUBD 15 SRG SUBD 25

Electrical Features				
Nominal Voltage	Un	12 V	12 V	12 V
Maximum Continuous Operating DC Voltage	Uc	15 V	15 V	15 V
C2 Nominal discharge current (8/20µs) line-shield	In	5 kA	5 kA	5 kA
C2 Nominal discharge current (8/20µs) shield-PG	In	10 kA	10 kA	10 kA
Voltage protection level (L-shield)	Up	≤40 V	≤40 V	≤40 V
Voltage protection level (shield-PG)	Up	≤500 V	≤500 V	≤500 V
Response time (L-shield))	tA	≤1 ns	≤1 ns	≤1 ns
Response time (shield-PG)	tA	≤100 ns	≤100 ns	≤100 ns
Bandwidth		10 Mbps	10 Mbps	10 Mbps
Insertion Loss		≤0,3 dB	≤0,3 dB	≤0,3 dB
Giriş-Çıkış		SUB-D 9 plug/socket	SUB-D 15 plug/socket	SUB-D 25 plug/socket
Pin		line 3/8, SG:5, PG:1	line 2/9/4/11, SG:8, PG:1	line: 2/3/4/5/6/8/20, SG:7, PG:1

Mechanical Features		
Operating temperature range	Ta	-40 C° to +80 C°
Humidity	RH	5%...%90
Casing Material		Aluminium Alloy
Degree of protection		IP40

DIMENSIONS

Product Weight:	32 gr
Packaged Weight:	40 gr
Package Dimensions (ExBxY)	35x60x20 mm



EARTHING



SMART CODING

Please use the following letter and number Codes to determine the combination of the metal desired product , the coat-ing and the type of bolt-nut group

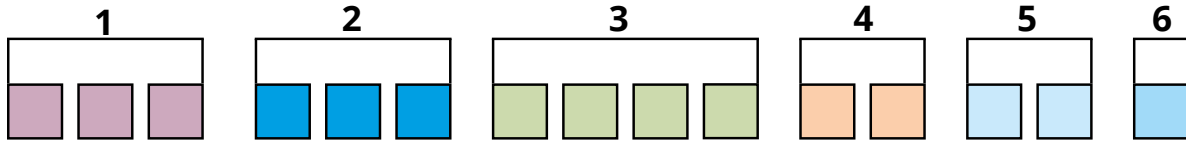

1. Product Group Code
2. Product Class Codes
3. Your Choice Of Size

4. Your Choice Of First Product Raw Material And Coating
5. Second Product Raw Material And Coating Preference
6. your choice of bolts and nuts

RAW MATERIAL, COATING AND BOLT SELECTION TABLE

RAW MATERIAL	
Code	Explication
D	Iron And Steel
B	Copper
N	Stainless
A	Aluminum
S	Brass
F	Bronze
G	Cast Iron
P	Plastic
C	Concrete

COATING	
Code	Explication
1	Electro Galvanized
2	Hot Galvanized
3	Electro Copper
4	Electro Tin
5	Nickel
6	Black isolations
7	Yellow-green isolation

BOLT	
Code	Explication
DC	Galvanized
NC	Stainless
SC	Brass

Sample Encodings



10 µm. Bakır Kaplama/ Coating thickness

Code	Material/Coating	Dia.	Lenght
TES.16.1000	D1-D3-B-N-D2	16 mm	1000 mm
TES.16.1200	D1-D3-B-N-D2	16 mm	1200 mm

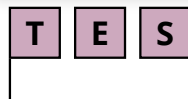

ROD SOIL
ELECTRODE

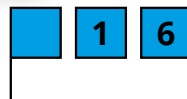

ROD
DIAMETER
16 mm

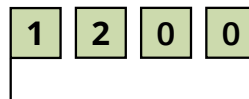

ROD SIZE
1200 mm

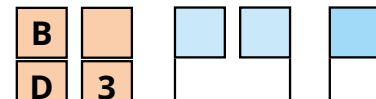

ROD MATERIAL
DESCRIPTION



Screw Type Conductor Clips

Kod Code	Casing Material/Kaplama Material/Coating	Civata Bolt	İletken Kesit Cross Section
IK.113.04	(D1+A)-(D1+B)-(D1+D1)-(D2+A)(D2+B)(D2+D2)-(N+A)-(N+B)-(N+N)	DC-NC	1x50mm ²
IK.113.05	(D1+A)-(D1+B)-(D1+D1)-(D2+A)(D2+B)(D2+D2)-(N+A)-(N+B)-(N+N)	DC-NC	1x70mm ²
IK.113.06	(D1+A)-(D1+B)-(D1+D1)-(D2+A)(D2+B)(D2+D2)-(N+A)-(N+B)-(N+N)	DC-NC	1x95mm ²



CONDUCTIVE
HOOK

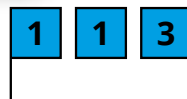

HOOK WITH
SCREW

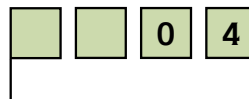

CONDUCTIVE
SECTION 50 mm²

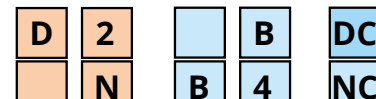

PEDESTAL
MATERIAL



RETAINER
MATERIAL



BOLT

IK.113.04.D2.B.DC SCREW CONDUCTOR CROWN, FOR 50mm² CONDUCTOR, HOT DIP GALVANIZED COATED PEDAL, COPPER HOLDER, GALVANIZED
IK.113.06.N.B4.NC SCREWED CONDUCTOR CROWN, FOR 95mm² CONDUCTOR, STAINLESS STEEL PAPER, TIN COATED COPPER HOLDER, STAINLESS BOLT

CONDUCTOR SPECS

Grounding products must be certified according to TS EN 62561.

The selection of casing material and cross-section for grounding conductors must be made according to various standards.

Annex A of the Regulation on Grounding Elements in Electrical Installations				
	Copper	Hot Dip Galvanized Steel	Copper-Plated Steel	Electrolytic Copper-Plated Steel
Round Conductor	25 mm ²	10 mm		
Braided Conductive	25 mm ² Each wire must have a diameter of at least 1.8 mm.			
Strip Conductor	50mm ²	30x3mm		
Electrode pipe	20 mm t=2mm.	25 mm t=2mm.		
Electrode (rod)		16 mm	15mm. t=2mm.	14,2mm.
Coating Thickness	-	at least 50 µm.		at least 90 µm.

Depending on the application and grounding requirements, special cross-sections and casing materials may be specified.

• TS EN 62305 Table 7 LIGHTNING PROTECTION SECTION 3: PHYSICAL DAMAGE TO BUILDINGS AND LIFE-THREATENING HAZARDS				
• TS EN 62561 LIGHTNING PROTECTION COMPONENTS CHAPTER 2: RULES FOR CONDUCTORS AND GROUND ELECTRODES • NFC 17-102:2011				
	Copper	"Hot-Dipped Galvanized Steel"	Copper-Plated Steel	Stainless
Round Conductor	50 mm ²	10 mm		10 mm
Braided Conductor	50 mm ² The diameter of each wire is at least 1.7mm.	70 mm ² The diameter of each wire is at least 1.7mm.		
Strip Conductor	50mm ²	30x3mm		50x2mm.
Electrode (Copper Earth Grid)	500x500x2 mm.	500x500x3 mm.		
Electrode (Copper plate)	600x600x2mm 25mm. Eye gap	600x600x3mm. 30mm. Eye gap		
Electrode (pipe)	20 mm t=2mm.	25 mm t=2mm.		
Electrode (rod)	15 mm.	16 mm	14mm.	15 mm. 16mm
Electrode (gusset)		50x50x3		
Coating Thickness	-	at least 50-70 µm.	at least 250 µm.	

CONDUCTORS

HOT DIP GALVANIZED STEEL CONDUCTORS

Earthing Strips



- Our products are certified according to **TS EN 62561-2 (62561-2)**.
- High-quality coating is applied using a continuous production line.
- Coating thickness is continuously measured and controlled.
- Coating is applied using high-quality zinc.
- Soft steel is used, allowing for easy installation.

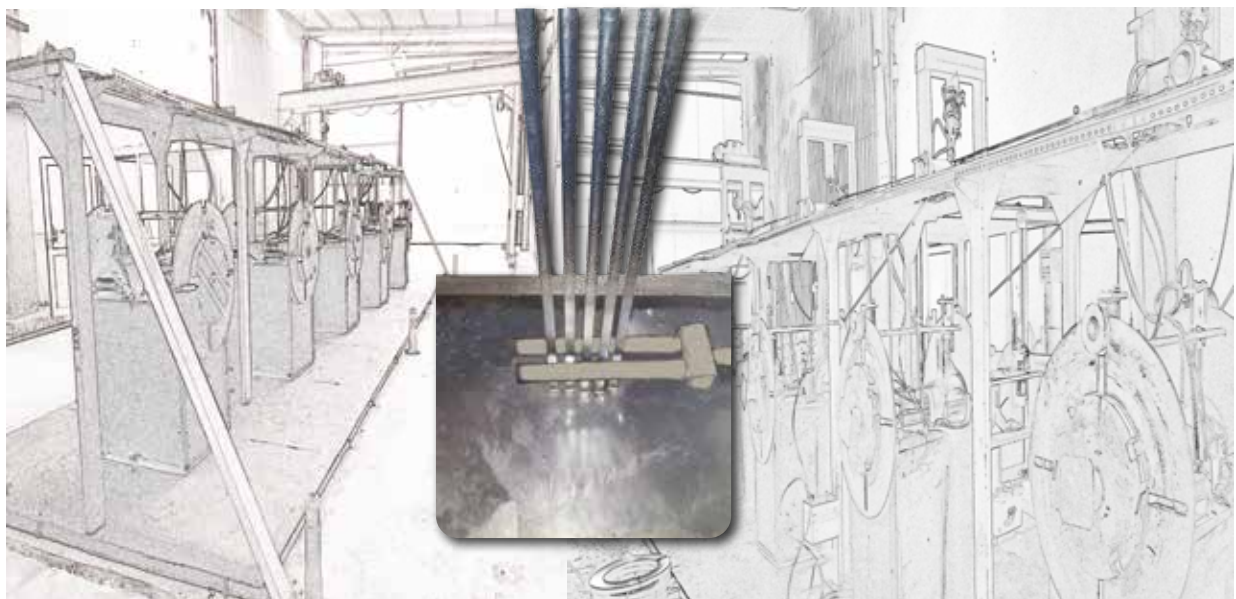

CONDUCTORS

HOT DIP GALVANIZED STEEL CONDUCTORS

Earthing Strips

Hot-dip galvanized conductors, electrodes and additional components can be used in grounding applications as clearly stated in the standards. Products produced using the hot dip galvanizing coating method are technically as useful as other metal products and have a very long economic life.

High resistance to corrosion:

Zinc coated by the hot dipping method protects steel against corrosion in 2 ways:

1. It wraps the steel and cuts off its contact with the soil.
2. Since zinc is a metal that acts as an anode compared to steel, it protects the steel cathodically around the points where the coating is damaged.

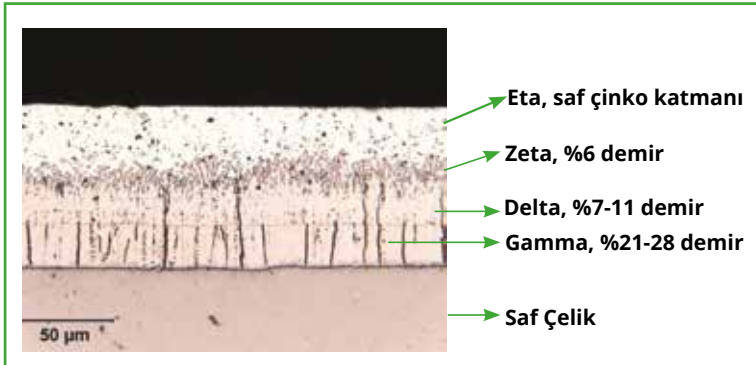

Causes of Corrosion:

1. **Acidic nature of the soil:** Geological structure of the soil or acidic vegetation such as pine tree needles.
2. **Dissolved salts in the soil:** potassium, sodium, calcium, magnesium. It is usually effective in areas with a lot of precipitation.

3. **High bacteria concentration:** Anaerobic bacteria damage steel in acidic soil.

4. **Low resistance soils**

Zinc Corrosion

The Corrosion Rate of Zinc According to pH		
TOPRAK pH	AVERAGE ZINC LOSS / YEAR	
	Dry Soil	Humidityli Soil
<4	<4	>6,5
4-4,9	4 - 4,9	2,6 - 5,2
5-7,9	5 - 7,9	2,2 - 4,3
8-9	8 - 9	3,3 - 6,5
>9	>9	>8,6

ZINC CORROSION RATE ACCORDING TO SOIL SPECIFIC RESISTANCE	
Soil Specific Resistance – ohm.cm	AVERAGE ZINC LOSS / YEAR
<500	>3,5
500 - 1000	1,5 - 3,5
1000 - 2000	1,3 - 1,5
2000 - 5000	0,9 - 1,5
>5000	<0,9

The tables are taken from the standard AS/NZS 2041:1998. / Zinc corrosion values are in microns.

MAIN MATERIAL

A=Aluminium, B=Copper, D=Iron-Steel, F=Bronze, G=Gray Cast Iron, N=Stainless, P=Plastic, S=Brass

COATINGS

1=Electrogalvanizing, 2=Hot Dip Galvanizing, 3=Electrodeposited Copper, 4=Electrodeposited Tin, 5=Electrodeposited Chromium-Nickel, 6=Black Insulation, 7=Yellow-Green Insulation

SCREW NUT

DC=Galvanizing, NC=Stainless, SC=Brass

CONDUCTORS

HOT DIP GALVANIZED STEEL CONDUCTORS

Earthing Strips



Product Code	Dimension (mm)	Length (m)	Weight
	A x T	H	Kg / m
CG.101.04	25x4	50	0,80
CG.101.33	30x3	50	0,75
CG.101.35	30x3,5	50	0,85
CG.101.13	40x4	40	1,30
CG.101.14	40x5	40	1,60
CG.101.16	50x5	40	2,00

Steel Grade : S235JR

Quality : TS EN 62561-2 Certified (TSE logo)
It is produced by continuous coating method.
Flux, impurities such as ash have been removed.

Packaging : On a wooden pallet, tied with metal / plastic hoop, covered with stretch film,

Branding : Radsan markası ve mekanik kazıma ve lazer markalama özellikli 50164-2 yazısı.

Tolerans : There is a tolerance of $\pm 10\%$ in thickness, $\pm 5\%$ in width, and $\pm 3\%$ in weight.



Köşebent için bakınız. Sayfa 200

MAIN MATERIAL

A=Aluminium, B=Copper, D=Iron-Steel,
F=Bronze, G=Gray Cast Iron,
N=Stainless, P=Plastic, S=Brass

COATINGS

1=Electrogalvanizing, 2=Hot Dip Galvanizing, 3=Electrodeposited Copper,
4=Electrodeposited Tin, 5=Electrodeposited Chromium-Nickel,
6=Black Insulation, 7=Yellow-Green Insulation

SCREW NUT

DC=Galvanizing,
NC=Stainless,
SC=Brass

HOT DIP GALVANIZED STEEL CONDUCTORS

Earthing Strip Holder



Code	Material Coating	Cross Section	Lenght
TE.500.01	D1-D2+N	up to 40x3 tape, 70mm round conductor	310 mm

Single Conductor

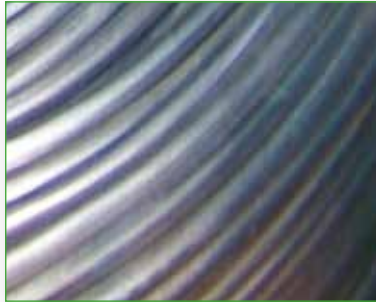

Code	Material	Cross Section	Dia.	Meter Weight
GD-101.08	D2	50 mm ²	8 mm	0,420 kg
GD -101.09	D2	70 mm ²	10 mm	0,600 kg

Stranded Conductor



Code	Material Coating	Conductor Size	Cross Section	Wire No x Wire Diameter n (Ea.) x Ø(mm)	Weight (Kg/m)
MH-08.06	D2	8 mm	35 mm ²	19 x 1,67	0,280
MH-08.08	D2	9,15 mm	50 mm ²	19 x 1,83	0,400
MH-08.09	D2	11,05 mm	70 mm ²	19 x 2,21	0,560
MH-08.10	D2	12,6 mm	96 mm ²	19 x 2,54	0,760

MAIN MATERIAL

A=Aluminium, B=Copper, D=Iron-Steel, F=Bronze, G=Gray Cast Iron, N=Stainless, P=Plastic, S=Brass

COATINGS

1=Electrogalvanizing, 2=Hot Dip Galvanizing, 3=Electrodeposited Copper, 4=Electrodeposited Tin, 5=Electrodeposited Chromium-Nickel, 6=Black Insulation, 7=Yellow-Green Insulation

SCREW NUT

DC=Galvanizing, NC=Stainless, SC=Brass

COPPER CONDUCTORS

Single Conductor



Code	Material	Cross Section	Dia.	Meter weight
CS-101.00	B	1,5 mm ²	1,36 mm	0,013 kg
CS-101.01	B	2,5 mm ²	1,76 mm	0,022 kg
CS-101.02	B	4 mm ²	2,2 mm	0,036 kg
CS-101.03	B	6 mm ²	2,8 mm	0,054 kg
CS-101.04	B	10 mm ²	4 mm	0,090 kg
CS-101.05	B	16 mm ²	5 mm	0,144 kg
CS-101.06	B	25 mm ²	6 mm	0,225 kg
CS-101.07	B	35 mm ²	7 mm	0,315 kg
CS-101.08	B	50 mm ²	8 mm	0,450 kg
CS-101.09	B	70 mm ²	10 mm	0,630 kg
CS-101.10	B	95 mm ²	12 mm	0,855 kg

Stranded Copper



Code	Material	Cross Section	Dia.	Meter weight
CO-101.04	B	10 mm ²	4,1 mm	0,090 kg
CO-101.05	B	16 mm ²	5,1 mm	0,144 kg
CO-101.06	B	25 mm ²	6,4 mm	0,225 kg
CO-101.07	B	35 mm ²	7,6 mm	0,315 kg
CO-101.08	B	50 mm ²	9 mm	0,450 kg
CO-101.09	B	70 mm ²	10,7 mm	0,630 kg
CO-101.10	B	95 mm ²	12,5 mm	0,855 kg
CO-101.11	B	120 mm ²	14,2 mm	1,080 kg
CO-101.12	B	150 mm ²	15,9 mm	1,350 kg
CO-101.13	B	185 mm ²	17,7 mm	1,665 kg
CO-101.14	B	240 mm ²	19,8 mm	2,160 kg

MAIN MATERIAL

A=Aluminium, B=Copper, D=Iron-Steel,
F=Bronze, G=Gray Cast Iron,
N=Stainless, P=Plastic, S=Brass

COATINGS

1=Electrogalvanizing, 2=Hot Dip Galvanizing, 3=Electrodeposited Copper,
4=Electrodeposited Tin, 5=Electrodeposited Chromium-Nickel,
6=Black Insulation, 7=Yellow-Green Insulation

SCREW NUT

DC=Galvanizing,
NC=Stainless,
SC=Brass

COPPER CONDUCTORS

NYA Earthing Cables

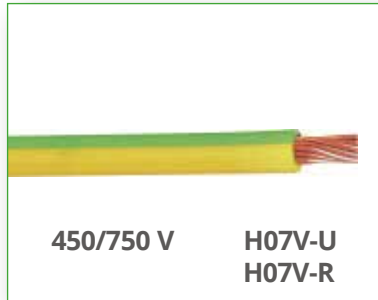

Code	Material	Cross Section	Meter weight
NYA-101.00	B7	1,5 mm ²	13 gr
NYA-101.01	B7	2,5 mm ²	23 gr
NYA-101.02	B7	4 mm ²	36 gr
NYA-101.03	B7	6 mm ²	0,060 gr
NYA-101.04	B7	10 mm ²	0,090 gr
NYA-101.05	B7	16 mm ²	0,144 gr
NYA-101.06	B7	25 mm ²	0,225 gr
NYA-101.07	B7	35 mm ²	0,315 gr
NYA-101.08	B7	50 mm ²	0,450 gr
NYA-101.09	B7	70 mm ²	0,630 gr
NYA-101.10	B7	95 mm ²	0,855 gr
NYA-101.11	B7	120 mm ²	1,080 gr
NYA-101.12	B7	150 mm ²	1,35 gr
NYA-101.13	B7	185 mm ²	1,665 gr
NYA-101.14	B7	240 mm ²	2,160 gr

NYAF Flexible Earthing Cables

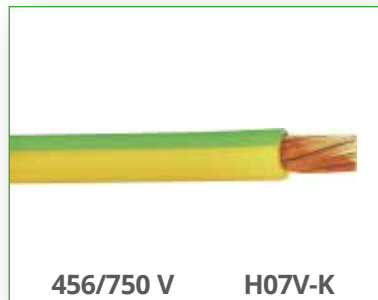

Code	Material	Cross Section	Meter weight
NYAF-101.03	B7	6 mm ²	0,070 kg
NYAF-101.04	B7	10 mm ²	0,115 kg
NYAF-101.05	B7	16 mm ²	0,175 kg
NYAF-101.06	B7	25 mm ²	0,270 kg
NYAF-101.07	B7	35 mm ²	0,370 kg
NYAF-101.08	B7	50 mm ²	0,525 kg
NYAF-101.09	B7	70 mm ²	0,700 kg
NYAF-101.10	B7	95 mm ²	0,970 kg
NYAF-101.11	B7	120 mm ²	1,200 kg
NYAF-101.12	B7	150 mm ²	1,500 kg
NYAF-101.13	B7	185 mm ²	1,860 kg
NYAF-101.14	B7	240 mm ²	2,400 kg

NY Y Earthing Cables

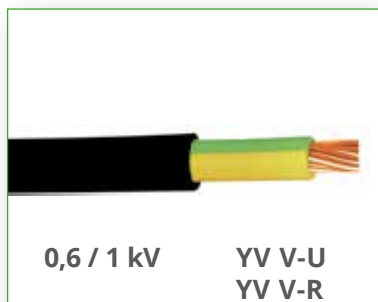

Code	Material	Cross Section	Meter weight
NY Y-101.02	B+ 6/7	4 mm ²	0,085 kg
NY Y-101.03	B+ 6/7	6 mm ²	0,105 kg
NY Y-101.04	B+ 6/7	10 mm ²	0,160 kg
NY Y-101.05	B+ 6/7	16 mm ²	0,215 kg
NY Y-101.06	B+ 6/7	25 mm ²	0,320 kg
NY Y-101.07	B+ 6/7	35 mm ²	0,420 kg
NY Y-101.08	B+ 6/7	50 mm ²	0,570 kg
NY Y-101.09	B+ 6/7	70 mm ²	0,780 kg
NY Y-101.10	B+ 6/7	95 mm ²	1,500 kg
NY Y-101.11	B+ 6/7	120 mm ²	1,300 kg
NY Y-101.12	B+ 6/7	150 mm ²	1,600 kg
NY Y-101.13	B+ 6/7	185 mm ²	1,950 kg
NY Y-101.14	B+ 6/7	240 mm ²	2,550 kg

MAIN MATERIAL

A=Aluminium, B=Copper, D=Iron-Steel,
F=Bronze, G=Gray Cast Iron,
N=Stainless, P=Plastic, S=Brass

COATINGS

1=Electrogalvanizing, 2=Hot Dip Galvanizing, 3=Electrodeposited Copper,
4=Electrodeposited Tin, 5=Electrodeposited Chromium-Nickel,
6=Black Insulation, 7=Yellow-Green Insulation

SCREW NUT

DC=Galvanizing,
NC=Stainless,
SC=Brass

COPPER CONDUCTORS

Copper Strips



Code	Material	Cross Section	Meter weight
CBR-100.02	B - B4 - B6 - B7	20x3 mm	0,540 kg
CBR-100.08	B - B4 - B6 - B7	30x2 mm	0,540 kg
CBR-100.09	B - B4 - B6 - B7	30x3 mm	0,810 kg

Copper Bars



Code	Material Coating	Cross Section	Meter weight
CB-101.01	B - B4 -B6 - B7	20x2 mm	0,360 kg
CB-101.02	B - B4 -B6 - B7	20x3 mm	0,540 kg
CB-101.03	B - B4 -B6 - B7	20x5 mm	0,900 kg
CB-101.04	B - B4 -B6 - B7	20x10 mm	1,800 kg
CB-101.05	B - B4 -B6 - B7	25x3 mm	0,675 kg
CB-101.06	B - B4 -B6 - B7	25x5 mm	1,125 kg
CB-101.07	B - B4 -B6 - B7	25x10 mm	2,250 kg
CB-101.08	B - B4 -B6 - B7	30x2 mm	0,540 kg
CB-101.09	B - B4 -B6 - B7	30x3 mm	0,810 kg
CB-101.10	B - B4 -B6 - B7	30x4 mm	1,080 kg
CB-101.11	B - B4 -B6 - B7	30x5 mm	1,350 kg
CB-101.12	B - B4 -B6 - B7	30x10 mm	2,700 kg
CB-101.13	B - B4 -B6 - B7	40x4 mm	1,440 kg
CB-101.14	B - B4 -B6 - B7	40x5 mm	1,800 kg
CB-101.15	B - B4 -B6 - B7	40x10 mm	3,600 kg
CB-101.16	B - B4 -B6 - B7	50x3 mm	1,350 kg
CB-101.17	B - B4 -B6 - B7	50x4 mm	1,800 kg
CB-101.18	B - B4 -B6 - B7	50x5 mm	2,250 kg
CB-101.19	B - B4 -B6 - B7	50x6 mm	2,700 kg
CB-101.20	B - B4 -B6 - B7	50x10 mm	4,500 kg
CB-101.21	B - B4 -B6 - B7	60x5 mm	2,700 kg
CB-101.22	B - B4 -B6 - B7	60x10 mm	5,400 kg
CB-101.23	B - B4 -B6 - B7	80x5 mm	3,600 kg
CB-101.24	B - B4 -B6 - B7	80x10 mm	7,200 kg
CB-101.25	B - B4 -B6 - B7	100x5 mm	4,500 kg
CB-101.26	B - B4 -B6 - B7	100x10 mm	9,000 kg



MAIN MATERIAL

A=Aluminium, B=Copper, D=Iron-Steel,
F=Bronze, G=Gray Cast Iron,
N=Stainless, P=Plastic, S=Brass

COATINGS

1=Electrogalvanizing, 2=Hot Dip Galvanizing, 3=Electrodeposited Copper,
4=Electrodeposited Tin, 5=Electrodeposited Chromium-Nickel,
6=Black Insulation, 7=Yellow-Green Insulation

SCREW NUT

DC=Galvanizing,
NC=Stainless,
SC=Brass

COPPER CONDUCTORS

Flexible Copper Braid, Round



Code	Material Coating	Cross Section	Dia	Meter weight
CFY-101.02	B-B4	4 mm ²	3,1	0.041 kg
CFY-101.03	B-B4	6 mm ²	4	0.056 kg
CFY-101.04	B-B4	10 mm ²	4,5	0.072 kg
CFY-101.05	B-B4	16 mm ²	5,7	0.122 kg
CFY-101.06	B-B4	25 mm ²	7,5	0.240 kg
CFY-101.07	B-B4	35 mm ²	9	0.346 kg
CFY-101.08	B-B4	50 mm ²	11	0.476 kg
CFY-101.09	B-B4	70 mm ²	13	0.663 kg
CFY-101.10	B-B4	95 mm ²	15	0.890 kg
CFY-101.11	B-B4	120 mm ²	17	1.080 kg
CFY-101.12	B-B4	150 mm ²	19	1.350 kg
CFY-101.13	B-B4	185 mm ²	21	1.665 kg
CFY-101.14	B-B4	240 mm ²	23	2.160 kg

Flexible Copper Braid, Strip

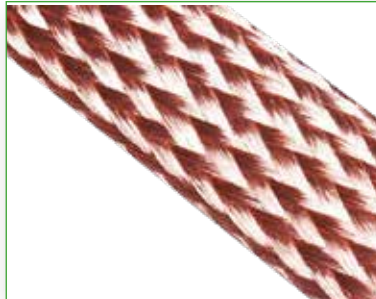

Code	Material Coating	Cross Section	a x b	Current DC	Meter weight
CFK-101.00	B-B4	1.5 mm	4x1 mm	21 A	0,017 kg
CFK-101.01	B-B4	2.5 mm	5.8x1 mm	30 A	0,027 kg
CFK-101.02	B-B4	4 mm	8,2x1 mm	34 A	0,043 kg
CFK-101.03	B-B4	6 mm	6.5x2 mm	44 A	0,060 kg
CFK-101.04	B-B4	10 mm	8x2 mm	60 A	0,100 kg
CFK-101.05	B-B4	16 mm	15x2 mm	82 A	0,160 kg
CFK-101.06	B-B4	25 mm	25x2,5 mm	110 A	0,250 kg
CFK-101.07	B-B4	35 mm	30x2,5 mm	135 A	0,350 kg
CFK-101.08	B-B4	50 mm	40x2,5 mm	168 A	0,500 kg
CFK-101.09	B-B4	70 mm	2(30x2,5) mm	260 A	0,700 kg

Flexible Copper Braid with Terminals



Code	Material	axb	Size	Cross Section	Weight
GE.300.00	B-B4	8x2	300 mm	10 mm ²	0,030 kg
GE.300.01	B-B4	15x2	300 mm	16 mm ²	0,048 kg
GE.300.02	B-B4	2(8x2)	300 mm	20 mm ²	0,060 kg
GE.300.03	B-B4	25x2,5	300 mm	25 mm ²	0,075 kg
GE.300.04	B-B4	30x2,5	300 mm	35 mm ²	0,105 kg
GE.300.05	B-B4	40x2,5	300 mm	50 mm ²	0,150 kg
GE.300.06	B-B4	2(30x2,5)	300 mm	70 mm ²	0,210 kg
GE.300.07	B-B4	2(40x2,5)	300 mm	95 mm ²	0,285 kg
GE.300.08	B-B4	3(30x2,5)	300 mm	120 mm ²	0,360 kg
GE.300.09	B-B4	3(40x2,5)	300 mm	150 mm ²	0,450 kg
GE.300.10	B-B4	5(30x2,5)	300 mm	185 mm ²	0,555 kg
GE.300.11	B-B4	4(40x2,5)	300 mm	200 mm ²	0,600 kg

MAIN MATERIAL

A=Aluminium, B=Copper, D=Iron-Steel, F=Bronze, G=Gray Cast Iron, N=Stainless, P=Plastic, S=Brass

COATINGS

1=Electrogalvanizing, 2=Hot Dip Galvanizing, 3=Electrodeposited Copper, 4=Electrodeposited Tin, 5=Electrodeposited Chromium-Nickel, 6=Black Insulation, 7=Yellow-Green Insulation

SCREW NUT

DC=Galvanizing, NC=Stainless, SC=Brass

EARTHING CLAMPS

For Round Conductors, 2 Pieces

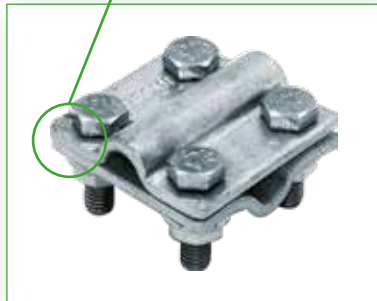
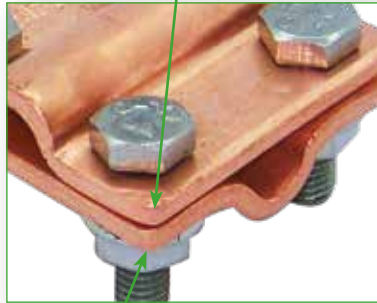
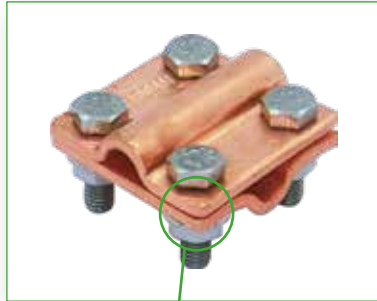

Code	Material Coating	Bolt	A Cross Sec.	B Cross Sec.
TDK 102.01	B-D1-D2-N	DC-NC	16 mm ²	16 mm ²
TDK 102.02	B-D1-D2-N	DC-NC	16 mm ²	25 mm ²
TDK 102.03	B-D1-D2-N	DC-NC	16 mm ²	35 mm ²
TDK 102.04	B-D1-D2-N	DC-NC	16 mm ²	50 mm ²
TDK 102.05	B-D1-D2-N	DC-NC	25 mm ²	25 mm ²
TDK 102.06	B-D1-D2-N	DC-NC	25 mm ²	35 mm ²
TDK 102.07	B-D1-D2-N	DC-NC	25 mm ²	50 mm ²
TDK 102.08	B-D1-D2-N	DC-NC	25 mm ²	70 mm ²
TDK 102.09	B-D1-D2-N	DC-NC	35 mm ²	35 mm ²
TDK 102.10	B-D1-D2-N	DC-NC	35 mm ²	50 mm ²
TDK 102.11	B-D1-D2-N	DC-NC	35 mm ²	70 mm ²
TDK 102.12	B-D1-D2-N	DC-NC	35 mm ²	95 mm ²
TDK 102.13	B-D1-D2-N	DC-NC	50 mm ²	50 mm ²
TDK 102.14	B-D1-D2-N	DC-NC	50 mm ²	70 mm ²
TDK 102.15	B-D1-D2-N	DC-NC	50 mm ²	95 mm ²
TDK 102.16	B-D1-D2-N	DC-NC	50 mm ²	120 mm ²
TDK 102.17	B-D1-D2-N	DC-NC	70 mm ²	70 mm ²
TDK 102.18	B-D1-D2-N	DC-NC	70 mm ²	95 mm ²
TDK 102.19	B-D1-D2-N	DC-NC	70 mm ²	120 mm ²
TDK 102.20	B-D1-D2-N	DC-NC	70 mm ²	150 mm ²
TDK 102.21	B-D1-D2-N	DC-NC	95 mm ²	95 mm ²
TDK 102.22	B-D1-D2-N	DC-NC	95 mm ²	120 mm ²
TDK 102.23	B-D1-D2-N	DC-NC	95 mm ²	150 mm ²
TDK 102.24	B-D1-D2-N	DC-NC	95 mm ²	185 mm ²
TDK 102.25	B-D1-D2-N	DC-NC	120 mm ²	120 mm ²
TDK 102.26	B-D1-D2-N	DC-NC	120 mm ²	150 mm ²
TDK 102.27	B-D1-D2-N	DC-NC	120 mm ²	185 mm ²
TDK 102.28	B-D1-D2-N	DC-NC	120 mm ²	240 mm ²
TDK 102.29	B-D1-D2-N	DC-NC	150 mm ²	150 mm ²
TDK 102.30	B-D1-D2-N	DC-NC	150 mm ²	185 mm ²
TDK 102.31	B-D1-D2-N	DC-NC	150 mm ²	240 mm ²
TDK 102.32	B-D1-D2-N	DC-NC	150 mm ²	300 mm ²

MAIN MATERIAL

A=Aluminium, B=Copper, D=Iron-Steel,
F=Bronze, G=Gray Cast Iron,
N=Stainless, P=Plastic, S=Brass

COATINGS

1=Electrogalvanizing, 2=Hot Dip Galvanizing, 3=Electrodeposited Copper,
4=Electrodeposited Tin, 5=Electrodeposited Chromium-Nickel,
6=Black Insulation, 7=Yellow-Green Insulation

SCREW NUT

DC=Galvanizing,
NC=Stainless,
SC=Brass

EARTHING CLAMPS

For Round Conductors, 3 Pieces

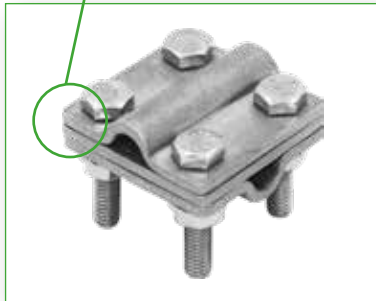
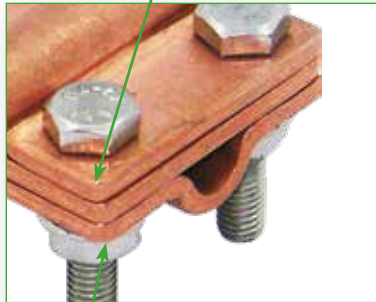
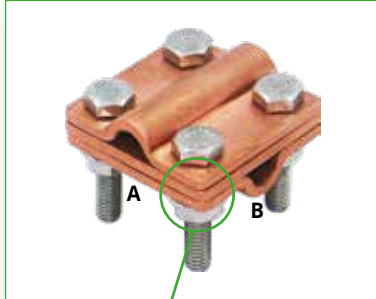

Code	Material Coating	Bolt	A Cross Sec.	B Cross Sec.
TDK 103.01	B-D1-D2-N	DC-NC	16 mm ²	16 mm ²
TDK 103.02	B-D1-D2-N	DC-NC	16 mm ²	25 mm ²
TDK 103.03	B-D1-D2-N	DC-NC	16 mm ²	35 mm ²
TDK 103.04	B-D1-D2-N	DC-NC	16 mm ²	50 mm ²
TDK 103.05	B-D1-D2-N	DC-NC	25 mm ²	25 mm ²
TDK 103.06	B-D1-D2-N	DC-NC	25 mm ²	35 mm ²
TDK 103.07	B-D1-D2-N	DC-NC	25 mm ²	50 mm ²
TDK 103.08	B-D1-D2-N	DC-NC	25 mm ²	70 mm ²
TDK 103.09	B-D1-D2-N	DC-NC	35 mm ²	35 mm ²
TDK 103.10	B-D1-D2-N	DC-NC	35 mm ²	50 mm ²
TDK 103.11	B-D1-D2-N	DC-NC	35 mm ²	70 mm ²
TDK 103.12	B-D1-D2-N	DC-NC	35 mm ²	95 mm ²
TDK 103.13	B-D1-D2-N	DC-NC	50 mm ²	50 mm ²
TDK 103.14	B-D1-D2-N	DC-NC	50 mm ²	70 mm ²
TDK 103.15	B-D1-D2-N	DC-NC	50 mm ²	95 mm ²
TDK 103.16	B-D1-D2-N	DC-NC	50 mm ²	120 mm ²
TDK 103.17	B-D1-D2-N	DC-NC	70 mm ²	70 mm ²
TDK 103.18	B-D1-D2-N	DC-NC	70 mm ²	95 mm ²
TDK 103.19	B-D1-D2-N	DC-NC	70 mm ²	120 mm ²
TDK 103.20	B-D1-D2-N	DC-NC	70 mm ²	150 mm ²
TDK 103.21	B-D1-D2-N	DC-NC	95 mm ²	95 mm ²
TDK 103.22	B-D1-D2-N	DC-NC	95 mm ²	120 mm ²
TDK 103.23	B-D1-D2-N	DC-NC	95 mm ²	150 mm ²
TDK 103.24	B-D1-D2-N	DC-NC	95 mm ²	185 mm ²
TDK 103.25	B-D1-D2-N	DC-NC	120 mm ²	120 mm ²
TDK 103.26	B-D1-D2-N	DC-NC	120 mm ²	150 mm ²
TDK 103.27	B-D1-D2-N	DC-NC	120 mm ²	185 mm ²
TDK 103.28	B-D1-D2-N	DC-NC	120 mm ²	240 mm ²
TDK 103.29	B-D1-D2-N	DC-NC	150 mm ²	150 mm ²
TDK 103.30	B-D1-D2-N	DC-NC	150 mm ²	185 mm ²
TDK 103.31	B-D1-D2-N	DC-NC	150 mm ²	240 mm ²
TDK 103.32	B-D1-D2-N	DC-NC	150 mm ²	300 mm ²

MAIN MATERIAL

A=Aluminium, B=Copper, D=Iron-Steel,
F=Bronze, G=Gray Cast Iron,
N=Stainless, P=Plastic, S=Brass

COATINGS

1=Electrogalvanizing, 2=Hot Dip Galvanizing, 3=Electrodeposited Copper,
4=Electrodeposited Tin, 5=Electrodeposited Chromium-Nickel,
6=Black Insulation, 7=Yellow-Green Insulation

SCREW NUT

DC=Galvanizing,
NC=Stainless,
SC=Brass

EARTHING CLAMPS

For Strips, 2 parts

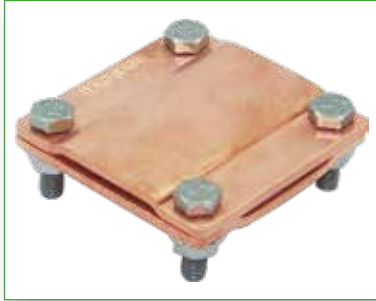

Code	Material Coating	Bolt	A Cross Sec.	B Cross Sec.
TDK.302.09	B-D1-D2-N	DC-NC	30X3 mm	30X3 mm
TDK.302.12	B-D1-D2-N	DC-NC	30X3,5 mm	30X3,5 mm
TDK.302.14	B-D1-D2-N	DC-NC	40X3-40X5 mm	40X3-40X5 mm
TDK.302.16	B-D1-D2-N	DC-NC	40X3-40X5 mm	50X3-50X5 mm
TDK.302.17	B-D1-D2-N	DC-NC	30X3-30X5 mm	40X3-40X5 mm
TDK.302.18	B-D1-D2-N	DC-NC	50X3-50X5 mm	50X3-50X5 mm



For Strips, 3 parts

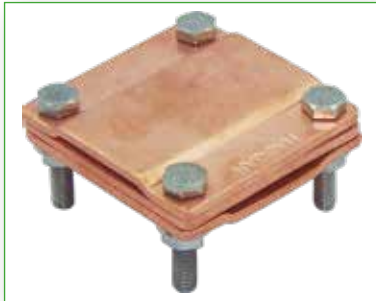

Code	Material Coating	Bolt	A Cross Sec.	B Cross Sec.
TDK.303.01	B-D1-D2-N	DC-NC	30X3 mm	30X3 mm
TDK.303.02	B-D1-D2-N	DC-NC	30X3-30X5 mm	30X3-30X5 mm
TDK.303.03	B-D1-D2-N	DC-NC	40X3-40X5 mm	40X3-40X5 mm
TDK.303.04	B-D1-D2-N	DC-NC	40X3-40X5 mm	50X3-50X5 mm
TDK.303.05	B-D1-D2-N	DC-NC	30X3-30X5 mm	40X3-40X5 mm
TDK.303.06	B-D1-D2-N	DC-NC	50X3-50X5 mm	50X3-50X5 mm



MAIN MATERIAL

A=Aluminium, B=Copper, D=Iron-Steel,
F=Bronze, G=Gray Cast Iron,
N=Stainless, P=Plastic, S=Brass

COATINGS

1=Electrogalvanizing, 2=Hot Dip Galvanizing, 3=Electrodeposited Copper,
4=Electrodeposited Tin, 5=Electrodeposited Chromium-Nickel,
6=Black Insulation, 7=Yellow-Green Insulation

SCREW NUT

DC=Galvanizing,
NC=Stainless,
SC=Brass

EARTHING CLAMPS

Round Section Conductive Strip Lamination Terminal

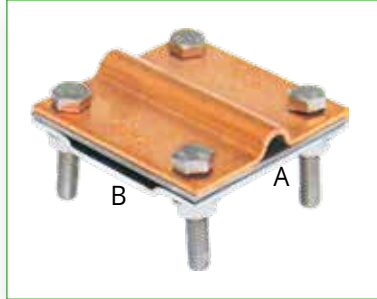

Code	Material Coating	Bolt	A Cross Sec.	B Cross Sec.
TDK.203.01	A-D1-D2-B-B4-N	DC-NC	10 - 120 mm ²	30x3 30x3,5 30x5 40x5

Round Conductor, Parallel Joint



Code	Material Coating	Bolt	Cross Sec.
TDK.108.01	A-D1-D2-B-B4-N	DC-NC	2x10 mm ²
TDK.108.02	A-D1-D2-B-B4-N	DC-NC	2x16 mm ²
TDK.108.03	A-D1-D2-B-B4-N	DC-NC	2x25 mm ²
TDK.108.45	A-D1-D2-B-B4-N	DC-NC	35/50 mm ²
TDK.108.06	A-D1-D2-B-B4-N	DC-NC	2x70 mm ²
TDK.108.07	A-D1-D2-B-B4-N	DC-NC	2x95 mm ²

Round Conductor, T and X Joint



Code	Material Coating	Bolt	Cross Sec.
TDK.109.01	A-B-B4-D1-D2-N	DC-NC	50/70 mm ²
TDK.109.02	A-B-B4-D1-D2-N	DC-NC	95 mm ²

MAIN MATERIAL

A=Aluminium, B=Copper, D=Iron-Steel,
F=Bronze, G=Gray Cast Iron,
N=Stainless, P=Plastic, S=Brass

COATINGS

1=Electrogalvanizing, 2=Hot Dip Galvanizing, 3=Electrodeposited Copper,
4=Electrodeposited Tin, 5=Electrodeposited Chromium-Nickel,
6=Black Insulation, 7=Yellow-Green Insulation

SCREW NUT

DC=Galvanizing,
NC=Stainless,
SC=Brass

EARTHING CLAMPS

Foundation



Code	Material Coating	Bolt	A Cross Sec.	B Cross Sec.
TDK.112.03	D1-D2-N	DC-NC	20x3 mm - 30x5 mm	ø12-ø20 mm
TDK.112.04	D1-D2-N	DC-NC	40x3 mm - 40x5 mm	ø20-ø26 mm



Code	Material Coating	Bolt	A Cross Sec.	B Cross Sec. Rebar Diameter
TDK.204.01	D1-D2-N	DC-NC	30x3 mm	14 mm
TDK.204.02	D1-D2-N	DC-NC	30x3 mm	16 mm
TDK.204.03	D1-D2-N	DC-NC	30x3 mm	18 mm
TDK.204.04	D1-D2-N	DC-NC	30x3 mm	20 mm
TDK.204.05	D1-D2-N	DC-NC	30x3 mm	22 mm
TDK.204.06	D1-D2-N	DC-NC	30x3 mm	24 mm
TDK.204.07	D1-D2-N	DC-NC	30x3 mm	26 mm
TDK.204.08	D1-D2-N	DC-NC	30x5 mm	14 mm
TDK.204.09	D1-D2-N	DC-NC	30x5 mm	16 mm
TDK.204.10	D1-D2-N	DC-NC	30x5 mm	18 mm
TDK.204.11	D1-D2-N	DC-NC	30x5 mm	20 mm
TDK.204.12	D1-D2-N	DC-NC	30x5 mm	22 mm
TDK.204.13	D1-D2-N	DC-NC	30x5 mm	24 mm
TDK.204.14	D1-D2-N	DC-NC	30x5 mm	26 mm
TDK.204.15	D1-D2-N	DC-NC	40x5 mm	14 mm
TDK.204.16	D1-D2-N	DC-NC	40x5 mm	16 mm
TDK.204.17	D1-D2-N	DC-NC	40x5 mm	18 mm
TDK.204.18	D1-D2-N	DC-NC	40x5 mm	20 mm
TDK.204.19	D1-D2-N	DC-NC	40x5 mm	22 mm
TDK.204.20	D1-D2-N	DC-NC	40x5 mm	24 mm
TDK.204.21	D1-D2-N	DC-NC	40x5 mm	26 mm

MAIN MATERIAL

A=Aluminium, B=Copper, D=Iron-Steel,
F=Bronze, G=Gray Cast Iron,
N=Stainless, P=Plastic, S=Brass

COATINGS

1=Electrogalvanizing, 2=Hot Dip Galvanizing, 3=Electrodeposited Copper,
4=Electrodeposited Tin, 5=Electrodeposited Chromium-Nickel,
6=Black Insulation, 7=Yellow-Green Insulation

SCREW NUT

DC=Galvanizing,
NC=Stainless,
SC=Brass

EARTHING CLAMPS

MC Connectors

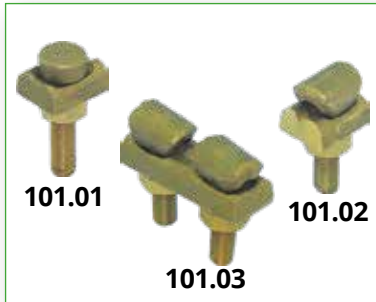

Code	Material Coating	Cross Section
MC.101.01	S	35 mm ² den 70 mm ²
MC.101.02	S	35 mm ² den 70 mm ²
MC.101.03	S	2x(35 den 70) mm ²

Parallel PMC Connectors



Code	Material Coating	A Cross Section	B Cross Section
PMC.101.01	B-S-F	50 - 95 mm ²	50 - 95 mm ²



Code	Material Coating	A Cross Section	B Cross Section
PMC.102.01	B-S-F	2 x 50 - 95 mm ²	2 x 50 - 95 mm ²



Code	Material Coating	A Cross Section	B Cross Section
PMC.103.01	B-S-F	25 - 95 mm ²	25 - 95 mm ²

MAIN MATERIAL

A=Aluminium, B=Copper, D=Iron-Steel, F=Bronze, G=Gray Cast Iron, N=Stainless, P=Plastic, S=Brass

COATINGS

1=Electrogalvanizing, 2=Hot Dip Galvanizing, 3=Electrodeposited Copper, 4=Electrodeposited Tin, 5=Electrodeposited Chromium-Nickel, 6=Black Insulation, 7=Yellow-Green Insulation

SCREW NUT

DC=Galvanizing, NC=Stainless, SC=Brass

EARTHING CLAMPS

Parallel PMC Connectors



Code	Material Coating	A Cross Section	B Cross Section
PMC.104.01	B-S-F	25 - 95 mm ²	25 - 95 mm ²



Code	Material Coating	A Cross Section	B Cross Section
PMC.105.01	B-S-F	95 - 95 mm ²	40 x 10 mm ²
PMC.105.02	B-S-F	120 - 120 mm ²	40 x 10 mm ²

Bimetallic Washer

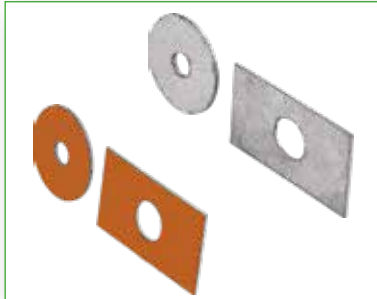

Code	Material Coating	Size	Bolt Hole	Description
PMC.108.01	(A+B)	ø30x1,5mm	ø8,5mm	Yuvarlak
PMC.108.02	(A+B)	55x36x1,5mm	ø14,5mm	Dikdörtgen

MAIN MATERIAL

A=Aluminium, B=Copper, D=Iron-Steel,
F=Bronze, G=Gray Cast Iron,
N=Stainless, P=Plastic, S=Brass

COATINGS

1=Electrogalvanizing, 2=Hot Dip Galvanizing, 3=Electrodeposited Copper,
4=Electrodeposited Tin, 5=Electrodeposited Chromium-Nickel,
6=Black Insulation, 7=Yellow-Green Insulation

SCREW NUT

DC=Galvanizing,
NC=Stainless,
SC=Brass

EARTHING CLAMPS

Ground Connectors, Clamps



Code	Material Coating	Bolt	Cross Section	Cross Section
TDK.501.01	F - S	DC+NC	16 mm ²	16 mm ²
TDK.501.02	F - S	DC+NC	25 mm ²	16 mm ²
TDK.501.03	F - S	DC+NC	25 mm ²	25 mm ²
TDK.501.04	F - S	DC+NC	35 mm ²	16 mm ²
TDK.501.05	F - S	DC+NC	35 mm ²	25 mm ²
TDK.501.06	F - S	DC+NC	35 mm ²	35 mm ²
TDK.501.07	F - S	DC+NC	50 mm ²	16 mm ²
TDK.501.08	F - S	DC+NC	50 mm ²	25 mm ²
TDK.501.09	F - S	DC+NC	50 mm ²	35 mm ²
TDK.501.10	F - S	DC+NC	50 mm ²	50 mm ²
TDK.501.11	F - S	DC+NC	70 mm ²	16 mm ²
TDK.501.12	F - S	DC+NC	70 mm ²	25 mm ²
TDK.501.13	F - S	DC+NC	70 mm ²	35 mm ²
TDK.501.14	F - S	DC+NC	70 mm ²	50 mm ²
TDK.501.15	F - S	DC+NC	70 mm ²	70 mm ²
TDK.501.16	F - S	DC+NC	95 mm ²	16 mm ²
TDK.501.17	F - S	DC+NC	95 mm ²	25 mm ²
TDK.501.18	F - S	DC+NC	95 mm ²	35 mm ²
TDK.501.19	F - S	DC+NC	95 mm ²	50 mm ²
TDK.501.20	F - S	DC+NC	95 mm ²	70 mm ²
TDK.501.21	F - S	DC+NC	95 mm ²	95 mm ²
TDK.501.22	F - S	DC+NC	120 mm ²	16 mm ²
TDK.501.23	F - S	DC+NC	120 mm ²	25 mm ²
TDK.501.24	F - S	DC+NC	120 mm ²	35 mm ²
TDK.501.25	F - S	DC+NC	120 mm ²	50 mm ²
TDK.501.26	F - S	DC+NC	120 mm ²	70 mm ²
TDK.501.27	F - S	DC+NC	120 mm ²	95 mm ²
TDK.501.28	F - S	DC+NC	120 mm ²	120 mm ²
TDK.501.29	F - S	DC+NC	150 mm ²	16 mm ²
TDK.501.30	F - S	DC+NC	150 mm ²	25 mm ²
TDK.501.31	F - S	DC+NC	150 mm ²	35 mm ²
TDK.501.32	F - S	DC+NC	150 mm ²	50 mm ²
TDK.501.33	F - S	DC+NC	150 mm ²	70 mm ²
TDK.501.34	F - S	DC+NC	150 mm ²	95 mm ²
TDK.501.35	F - S	DC+NC	150 mm ²	120 mm ²
TDK.501.36	F - S	DC+NC	150 mm ²	150 mm ²
TDK.501.37	F - S	DC+NC	185 mm ²	50 mm ²
TDK.501.38	F - S	DC+NC	185 mm ²	70 mm ²
TDK.501.39	F - S	DC+NC	185 mm ²	95 mm ²
TDK.501.40	F - S	DC+NC	185 mm ²	120 mm ²
TDK.501.41	F - S	DC+NC	185 mm ²	150 mm ²
TDK.501.42	F - S	DC+NC	185 mm ²	185 mm ²
TDK.501.43	F - S	DC+NC	240 mm ²	50 mm ²
TDK.501.44	F - S	DC+NC	240 mm ²	70 mm ²
TDK.501.45	F - S	DC+NC	240 mm ²	95 mm ²
TDK.501.46	F - S	DC+NC	240 mm ²	120 mm ²
TDK.501.47	F - S	DC+NC	240 mm ²	150 mm ²
TDK.501.48	F - S	DC+NC	240 mm ²	185 mm ²
TDK.501.49	F - S	DC+NC	240 mm ²	240 mm ²

MAIN MATERIAL

A=Aluminium, B=Copper, D=Iron-Steel,
F=Bronze, G=Gray Cast Iron,
N=Stainless, P=Plastic, S=Brass

COATINGS

1=Electrogalvanizing, 2=Hot Dip Galvanizing, 3=Electrodeposited Copper,
4=Electrodeposited Tin, 5=Electrodeposited Chromium-Nickel,
6=Black Insulation, 7=Yellow-Green Insulation

SCREW NUT

DC=Galvanizing,
NC=Stainless,
SC=Brass

EARTHING CLAMPS

Ground Connectors, Clamps



Code	Material Coating	Bolt	Cross Section	Cross Section
TDK.502.01	F - S	DC+NC	10 mm ²	25 mm ²
TDK.502.02	F - S	DC+NC	25 mm ²	70 mm ²
TDK.502.03	F - S	DC+NC	70 mm ²	120 mm ²
TDK.502.04	F - S	DC+NC	150 mm ²	240 mm ²
TDK.502.05	F - S	DC+NC	240 mm ²	400 mm ²
TDK.502.06	F - S	DC+NC	400 mm ²	500 mm ²



Code	Material Coating	Bolt	Cross Section	Cross Section
BES.113.01	F - S	DC-NC	16 / 20 mm ²	2x50 mm ²
BES.113.02	F - S	DC-NC	16 / 20 mm ²	2x70 mm ²
BES.113.03	F - S	DC-NC	16 / 20 mm ²	2x95 mm ²



Code	Material Coating	Bolt	Dia	Cross Section
BEB.114.01	F - S	DC-NC	½"	2x50 mm ²
BEB.114.02	F - S	DC-NC	¾"	2x50 mm ²
BEB.114.03	F - S	DC-NC	1"	2x50 mm ²
BEB.114.04	F - S	DC-NC	1¼"	2x50 mm ²
BEB.114.05	F - S	DC-NC	1½"	2x50 mm ²
BEB.114.06	F - S	DC-NC	2"	2x50 mm ²
BEB.114.07	F - S	DC-NC	2½"	2x50 mm ²
BEB.114.08	F - S	DC-NC	3"	2x50 mm ²
BEB.115.01	F - S	DC-NC	½"	2x70 mm ²
BEB.115.02	F - S	DC-NC	¾"	2x70 mm ²
BEB.115.03	F - S	DC-NC	1"	2x70 mm ²
BEB.115.04	F - S	DC-NC	1¼"	2x70 mm ²
BEB.115.05	F - S	DC-NC	1½"	2x70 mm ²
BEB.115.06	F - S	DC-NC	2"	2x70 mm ²
BEB.115.07	F - S	DC-NC	2½"	2x70 mm ²
BEB.115.08	F - S	DC-NC	3"	2x70 mm ²
BEB.116.01	F - S	DC-NC	½"	2x95 mm ²
BEB.116.02	F - S	DC-NC	¾"	2x95 mm ²
BEB.116.03	F - S	DC-NC	1"	2x95 mm ²
BEB.116.04	F - S	DC-NC	1¼"	2x95 mm ²
BEB.116.05	F - S	DC-NC	1½"	2x95 mm ²
BEB.116.06	F - S	DC-NC	2"	2x95 mm ²
BEB.116.07	F - S	DC-NC	2½"	2x95 mm ²
BEB.116.08	F - S	DC-NC	3"	2x95 mm ²

MAIN MATERIAL

A=Aluminium, B=Copper, D=Iron-Steel,
F=Bronze, G=Gray Cast Iron,
N=Stainless, P=Plastic, S=Brass

COATINGS

1=Electrogalvanizing, 2=Hot Dip Galvanizing, 3=Electrodeposited Copper,
4=Electrodeposited Tin, 5=Electrodeposited Chromium-Nickel,
6=Black Insulation, 7=Yellow-Green Insulation

SCREW NUT

DC=Galvanizing,
NC=Stainless,
SC=Brass

EARTHING CLAMPS

Ground Connectors, Clamps



Code	Material / Coating
LCR.101	From 25 to 120 mm ² screw hole dimension is from ø10 to ø15

Connection Clamps "Claw Type"



Code	Material Coating	Cross Section	Bolt
RTK.101.01	S	16 mm ²	DC / NC / SC
RTK.101.02	S	25 mm ²	DC / NC / SC
RTK.101.03	S	35 mm ²	DC / NC / SC
RTK.101.04	S	50 mm ²	DC / NC / SC
RTK.101.05	S	70 mm ²	DC / NC / SC
RTK.101.07	S	95 - 120 mm ²	DC / NC / SC

MAIN MATERIAL

A=Aluminium, B=Copper, D=Iron-Steel,
F=Bronze, G=Gray Cast Iron,
N=Stainless, P=Plastic, S=Brass

COATINGS

1=Electrogalvanizing, 2=Hot Dip Galvanizing, 3=Electrodeposited Copper,
4=Electrodeposited Tin, 5=Electrodeposited Chromium-Nickel,
6=Black Insulation, 7=Yellow-Green Insulation

SCREW NUT

DC=Galvanizing,
NC=Stainless,
SC=Brass

EARTHING CLAMPS

C Type Compression Clamps



Code	Material Coating	Cross Sec.	Cross Section
SKC.101.02	B-B4	35 mm ²	50 mm ²
SKC.101.03	B-B4	50 mm ²	50 mm ²
SKC.101.04	B-B4	70 mm ²	70 mm ²
SKC.101.06	B-B4	95 mm ²	120 mm ²
SKC.101.09	B-B4	120 mm ²	120 mm ²

H Type Compression Clamps



Code	Material Coating	Cross Sec. (mm ²)	Cross Section
SKH.102.01	B-B4	50 mm ²	50 mm ²
SKH.102.02	B-B4	50 mm ²	70 mm ²
SKH.102.03	B-B4	50 mm ²	95 mm ²
SKH.102.04	B-B4	50 mm ²	120 mm ²
SKH.102.05	B-B4	95 mm ²	120 mm ²
SKH.102.06	B-B4	70 mm ²	70 mm ²
SKH.102.07	B-B4	70 mm ²	120 mm ²
SKH.102.08	B-B4	95 mm ²	120 mm ²
SKH.102.09	B-B4	120 mm ²	120 mm ²
SKH.102.10	B-B4	240 mm ²	240 mm ²

MAIN MATERIAL

A=Aluminium, B=Copper, D=Iron-Steel,
F=Bronze, G=Gray Cast Iron,
N=Stainless, P=Plastic, S=Brass

COATINGS

1=Electrogalvanizing, 2=Hot Dip Galvanizing, 3=Electrodeposited Copper,
4=Electrodeposited Tin, 5=Electrodeposited Chromium-Nickel,
6=Black Insulation, 7=Yellow-Green Insulation

SCREW NUT

DC=Galvanizing,
NC=Stainless,
SC=Brass

EARTHING CLAMPS

(SS) Connectors



Code	Material/Coating	Cross Section	A Bolt Size
SS.101.04	S-S4	1x25 mm ²	M6x10 mm
SS.101.05	S-S4	1x35 mm ²	M6x10 mm
SS.101.06	S-S4	1x50 mm ²	M6x10 mm
SS.101.07	S-S4	1x70 mm ²	M6x15 mm
SS.101.08	S-S4	1x95 mm ²	M8x15 mm
SS.101.09	S-S4	1x120 mm ²	M8x15 mm
SS.101.10	S-S4	1x150 mm ²	M10x20 mm
SS.101.11	S-S4	1x185 mm ²	M10x20 mm



Code	Material/Coating	Cross Section	A Bolt Size
SS.102.04	S-S4	2 x 25 mm ²	M6x10 mm
SS.102.05	S-S4	2 x 35 mm ²	M6x10 mm
SS.102.06	S-S4	2 x 50 mm ²	M6x10 mm
SS.102.07	S-S4	2 x 70 mm ²	M6x15 mm
SS.102.08	S-S4	2 x 95 mm ²	M8x15 mm
SS.102.09	S-S4	2 x 120 mm ²	M8x15 mm
SS.102.10	S-S4	2 x 150 mm ²	M10x20 mm
SS.102.11	S-S4	2 x 185 mm ²	M10x20 mm



Code	Material/Coating	Cross Section	A Bolt Size
SS.103.04	S-S4	1x25 mm ²	M6x10 mm
SS.103.05	S-S4	1x35 mm ²	M6x10 mm
SS.103.06	S-S4	1x50 mm ²	M6x10 mm
SS.103.07	S-S4	1x70 mm ²	M6x15 mm
SS.103.08	S-S4	1x95 mm ²	M8x15 mm
SS.103.09	S-S4	1x120 mm ²	M8x15 mm
SS.103.10	S-S4	1x150 mm ²	M10x20 mm
SS.103.11	S-S4	1x185 mm ²	M10x20 mm



Code	Material/Coating	Cross Section	A Bolt Size
SS.104.04	S-S4-F	2 x 25 mm ²	M6x10 mm
SS.104.05	S-S4-F	2 x 35 mm ²	M6x10 mm
SS.104.06	S-S4-F	2 x 50 mm ²	M6x10 mm
SS.104.07	S-S4-F	2 x 70 mm ²	M6x15 mm
SS.104.08	S-S4-F	2 x 95 mm ²	M8x15 mm
SS.104.09	S-S4-F	2 x 120 mm ²	M8x15 mm
SS.104.10	S-S4-F	2 x 150 mm ²	M10x20 mm
SS.104.11	S-S4-F	2 x 185 mm ²	M10x20 mm

MAIN MATERIAL

A=Aluminium, B=Copper, D=Iron-Steel,
F=Bronze, G=Gray Cast Iron,
N=Stainless, P=Plastic, S=Brass

COATINGS

1=Electrogalvanizing, 2=Hot Dip Galvanizing, 3=Electrodeposited Copper,
4=Electrodeposited Tin, 5=Electrodeposited Chromium-Nickel,
6=Black Insulation, 7=Yellow-Green Insulation

SCREW NUT

DC=Galvanizing,
NC=Stainless,
SC=Brass

EARTHING CLAMPS

(SS) Connectors



Code	Material / Coating	Cross Section	Cross Section
SS.105.04	S-S4	1x25 mm ²	2x25 mm ²
SS.105.05	S-S4	1x35 mm ²	2x35 mm ²
SS.105.06	S-S4	1x50 mm ²	2x50 mm ²
SS.105.07	S-S4	1x70 mm ²	2x70 mm ²
SS.105.08	S-S4	1x95 mm ²	2x95 mm ²
SS.105.09	S-S4	1x120 mm ²	2x120 mm ²
SS.105.10	S-S4	1x150 mm ²	2x150 mm ²
SS.105.11	S-S4	1x185 mm ²	2x185 mm ²



Code	Material/Coating	Cross Section
SS.106.01	S-S4	25 mm ² - 35 mm ²
SS.106.02	S-S4	50 mm ² - 70 mm ²
SS.106.03	S-S4	95 mm ² - 120 mm ²

U Clamp



Code	Material/Coating	Cross Section
UK.104.01	S	6
UK.104.02	S	10
UK.104.03	S	16
UK.104.04	S	25
UK.104.05	S	35
UK.104.06	S	50
UK.104.07	S	70
UK.104.08	S	95
UK.104.09	S	120
UK.105.100	<i>U Clamp Cover Plastic</i>	

U Bolt



Code	Material/Coating	Cross Section
UB.120	N - D1	M6
UB.120	N - D1	M8

MAIN MATERIAL

A=Aluminium, B=Copper, D=Iron-Steel,
F=Bronze, G=Gray Cast Iron,
N=Stainless, P=Plastic, S=Brass

COATINGS

1=Electrogalvanizing, 2=Hot Dip Galvanizing, 3=Electrodeposited Copper,
4=Electrodeposited Tin, 5=Electrodeposited Chromium-Nickel,
6=Black Insulation, 7=Yellow-Green Insulation

SCREW NUT

DC=Galvanizing,
NC=Stainless,
SC=Brass

ELECTRODES

GALVANIZED ELECTRODES

L Profile Earthing Rod



Code	Material Coating	Cross Section	Lenght	Weight
TE.403.01	D1-D2-N	40x40x4	1000mm	2,420 kg
TE.403.02	D1-D2-N	40x40x4	1500mm	3,630 kg
TE.403.03	D1-D2-N	40x40x4	2000mm	4,840 kg
TE.403.04	D1-D2-N	50x50x5	1000mm	3,770 kg
TE.403.05	D1-D2-N	50x50x5	1500mm	5,655 kg
TE.403.06	D1-D2-N	50x50x5	2000mm	7,540 kg
TE.403.07	D1-D2-N	60x60x4	1000mm	3,700 kg
TE.403.08	D1-D2-N	60x60x4	1500mm	5,550 kg
TE.403.09	D1-D2-N	60x60x4	2000mm	7,400 kg
TE.403.10	D1-D2-N	60x60x5	1000mm	4,570 kg
TE.403.11	D1-D2-N	60x60x5	1500mm	4,855 kg
TE.403.12	D1-D2-N	60x60x5	2000mm	9,140 kg
TE.403.13	D1-D2-N	60x60x6	1000mm	5,420 kg
TE.403.14	D1-D2-N	60x60x6	1500mm	8,130 kg
TE.403.15	D1-D2-N	60x60x6	2000mm	10,840 kg
TE.403.16	D1-D2-N	65x65x5	1000mm	4,970 kg
TE.403.17	D1-D2-N	65x65x5	1500mm	7,455 kg
TE.403.18	D1-D2-N	65x65x5	2000mm	9,940 kg
TE.403.19	D1-D2-N	65x65x6	1000mm	5,910 kg
TE.403.20	D1-D2-N	65x65x6	1500mm	8,865 kg
TE.403.21	D1-D2-N	65x65x6	2000mm	11,820 kg
TE.403.22	D1-D2-N	65x65x7	1000mm	6,830 kg
TE.403.23	D1-D2-N	65x65x7	1500mm	10,245 kg
TE.403.24	D1-D2-N	65x65x7	2000mm	13,660 kg

For strip or round conductor welded profiles, the above table is valid excluding weight.

Round Electrode



Code	Material Coating	Dia.	Lenght	Weight
TES.16.1000	D2 - N	Ø16	1000mm	1,600 kg
TES.18.1500		Ø18	1500mm	3,000 kg
TES.20.1000		Ø20	3000mm	7,500 kg

MAIN MATERIAL

A=Aluminium, B=Copper, D=Iron-Steel, F=Bronze, G=Gray Cast Iron, N=Stainless, P=Plastic, S=Brass

COATINGS

1=Electrogalvanizing, 2=Hot Dip Galvanizing, 3=Electrodeposited Copper, 4=Electrodeposited Tin, 5=Electrodeposited Chromium-Nickel, 6=Black Insulation, 7=Yellow-Green Insulation

SCREW NUT

DC=Galvanizing, NC=Stainless, SC=Brass

COPPER ELECTRODES

Round copper Single



Code	Dia.	Lenght	Unit Weight
TES.16.1000.B	Ø16	1 mt	1,800 kg
TES.16.1500.B	Ø16	1.5 mt	2,700 kg
TES.16.3000.B	Ø16	3 mt	5,400 kg
TES.18.1000.B	Ø18	1 mt	2,300 kg
TES.18.1500.B	Ø18	1.5 mt	3,450 kg
TES.18.3000.B	Ø18	3 mt	6,900 kg
TES.20.1000.B	Ø20	1 mt	2,700 kg
TES.20.1500.B	Ø20	1.5 mt	4,000 kg
TES.20.3000.B	Ø20	3 mt	8,000 kg

Round copper Threaded



Code	Dia.	Lenght	Unit Weight
TED.16.1000.B	Ø16	1 mt	1,800 kg
TED.16.1500.B	Ø16	1.5 mt	2,700 kg
TED.16.3000.B	Ø16	3 mt	5,400 kg
TED.18.1000.B	Ø18	1 mt	2,300 kg
TED.18.1500.B	Ø18	1.5 mt	3,450 kg
TED.18.3000.B	Ø18	3 mt	6,900 kg
TED.20.1000.B	Ø20	1 mt	2,700 kg
TED.20.1500.B	Ø20	1.5 mt	4,000 kg
TED.20.3000.B	Ø20	3 mt	8,000 kg

Coating thickness Single

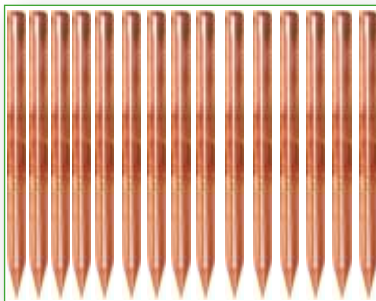

Code	Dia.	Lenght	Unit Weight
TES.16.1000.D3	Ø16	1 mt	1,6 kg
TES.16.1500.D3	Ø16	1.5 mt	2,4 kg
TES.16.3000.D3	Ø16	3 mt	4,8 kg
TES.18.1000.D3	Ø18	1 mt	2 kg
TES.18.1500.D3	Ø18	1.5 mt	3 kg
TES.18.3000.D3	Ø18	3 mt	6 kg
TES.20.1000.D3	Ø20	1 mt	2,5 kg
TES.20.1500.D3	Ø20	1.5 mt	3,75 kg
TES.20.3000.D3	Ø20	3 mt	7,5 kg

MAIN MATERIAL

A=Aluminium, B=Copper, D=Iron-Steel,
F=Bronze, G=Gray Cast Iron,
N=Stainless, P=Plastic, S=Brass

COATINGS

1=Electrogalvanizing, 2=Hot Dip Galvanizing, 3=Electrodeposited Copper,
4=Electrodeposited Tin, 5=Electrodeposited Chromium-Nickel,
6=Black Insulation, 7=Yellow-Green Insulation

SCREW NUT

DC=Galvanizing,
NC=Stainless,
SC=Brass

COPPER ELECTRODES

Coating thickness Threaded



Code	Dia.	Lenght	Unit Weight
TED.16.1000.D3	Ø16	1 mt	1,60 kg
TED.16.1500.D3	Ø16	1.5 mt	2,40 kg
TED.16.3000.D3	Ø16	3 mt	4,80 kg
TED.18.1000.D3	Ø18	1 mt	2,00 kg
TED.18.1500.D3	Ø18	1.5 mt	3,00 kg
TED.18.3000.D3	Ø18	3 mt	6,00 kg
TED.20.1000.D3	Ø20	1 mt	2,50 kg
TED.20.1500.D3	Ø20	1.5 mt	3,75 kg
TED.20.3000.D3	Ø20	3 mt	7,50 kg

Coating thickness Single

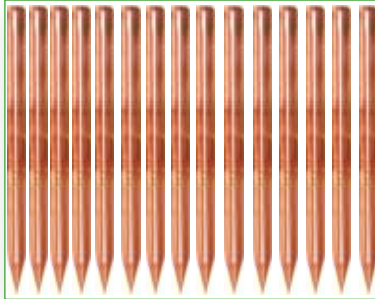

Code	Dia.	Lenght	Unit Weight
TES.16.1000.D+B	Ø16	1 mt	1,630 kg
TES.16.1500.D+B	Ø16	1.5 mt	2,450 kg
TES.16.3000.D+B	Ø16	3 mt	4.900 kg
TES.18.1000.D+B	Ø18	1 mt	2.055 kg
TES.18.1500.D+B	Ø18	1.5 mt	3,085 kg
TES.18.3000.D+B	Ø18	3 mt	6,165 kg
TES.20.1000.D+B	Ø20	1 mt	2,530 kg
TES.20.1500.D+B	Ø20	1.5 mt	3,800 kg
TES.20.2000.D+B	Ø20	2 mt	7,600 kg
TES 22.2500.3.D+B	Ø22	2500mm	8,000 kg

Coating thickness Single



Code	Dia.	Lenght	Unit Weight
TED.16.1000.D+B	Ø16	1 mt	1,630 kg
TED.16.1500.D+B	Ø16	1.5 mt	2,450 kg
TED.16.3000.D+B	Ø16	3 mt	4.900 kg
TED.18.1000.D+B	Ø18	1 mt	2.055 kg
TED.18.1500.D+B	Ø18	1.5 mt	3,085 kg
TED.18.3000.D+B	Ø18	3 mt	6,165 kg
TED.20.1000.D+B	Ø20	1 mt	2,530 kg
TED.20.1500.D+B	Ø20	1.5 mt	3,800 kg
TED.20.2000.D+B	Ø20	3 mt	7,600 kg
TED 22D+B.2500.3.D+B	Ø22	2500 mm	8,000 kg

MAIN MATERIAL

A=Aluminium, B=Copper, D=Iron-Steel,
F=Bronze, G=Gray Cast Iron,
N=Stainless, P=Plastic, S=Brass

COATINGS

1=Electrogalvanizing, 2=Hot Dip Galvanizing, 3=Electrodeposited Copper,
4=Electrodeposited Tin, 5=Electrodeposited Chromium-Nickel,
6=Black Insulation, 7=Yellow-Green Insulation

SCREW NUT

DC=Galvanizing,
NC=Stainless,
SC=Brass

Coupler



Code	Explanation	
YTE.102.02	GALVANİZLİ ÇELİK	M12
YTE.102.02	PASLANMAZ	M12

Driving Stud



Code	Explanation	
YTS.103.02	GALVANİZLİ ÇELİK	M12
YTS.103.02	PASLANMAZ	M12

Spike



Code	Explanation	
YTS.104.02	GALVANİZLİ ÇELİK	M12
YTS.104.02	PASLANMAZ	M12

MAIN MATERIAL

A=Aluminium, B=Copper, D=Iron-Steel,
F=Bronze, G=Gray Cast Iron,
N=Stainless, P=Plastic, S=Brass

COATINGS

1=Electrogalvanizing, 2=Hot Dip Galvanizing, 3=Electrodeposited Copper,
4=Electrodeposited Tin, 5=Electrodeposited Chromium-Nickel,
6=Black Insulation, 7=Yellow-Green Insulation

SCREW NUT

DC=Galvanizing,
NC=Stainless,
SC=Brass

EARTHING PLATES

Earthing Plate, Steel or Copper



Code	Explanation
ELT-101.10	70x70cm - 1mm Bakır
ELT-101.15	70x70cm - 1.5mm Bakır
ELT-101.20	70x70cm - 2mm Bakır
ELT-101.30	70x70cm - 3mm Bakır
ELT-102.20	100x50cm - 2mm Sıcak Galvaniz Kaplı
ELT-102.30	100x50cm - 3mm Sıcak Galvaniz Kaplı

Earthing Grid



Code	Material/Coating	Length	Thickness
ELT-103.01	B-D2	1000 x 500 mm	2 mm
ELT-103.02	B-D2	1000 x 1000 mm	2 mm
ELT-103.03	B-D2	1000 x 2000 mm	2 mm
ELT-103.04	B-D2	1000 x 4000 mm	2 mm

MAIN MATERIAL

A=Aluminium, B=Copper, D=Iron-Steel,
F=Bronze, G=Gray Cast Iron,
N=Stainless, P=Plastic, S=Brass

COATINGS

1=Electrogalvanizing, 2=Hot Dip Galvanizing, 3=Electrodeposited Copper,
4=Electrodeposited Tin, 5=Electrodeposited Chromium-Nickel,
6=Black Insulation, 7=Yellow-Green Insulation

SCREW NUT

DC=Galvanizing,
NC=Stainless,
SC=Brass

EARTHING ROD CONNECTORS



Code	Material Coating	Rod Dia.	Cross Section
CEB.101.01	B-D1-N-S	ø16 - 22 mm	16-70 mm ²
CEB.101.03	B-D1-N-S	ø18 - 22 mm	95-240 mm ²
CEB.101.04	S	ø16 - 20 mm	1x50-2x50mm ² 30x5



Code	Material Coating	Rod Dia.	Cross Section
CEB.105.01	B-F-S	ø16 mm	2 x 50 mm ²
CEB.105.02	B-F-S	ø18 mm	2 x 50 mm ²
CEB.105.03	B-F-S	ø20 mm	2 x 50 mm ²



Code	Material Coating	Bolt	Rod Dia.	Cross Section
CEB.109.16.21	B-D1-D2-N	DC-NC	ø16 mm	2 x 50 mm ²
CEB.109.16.22	B-D1-D2-N	DC-NC	ø16 mm	2 x 70 mm ²
CEB.109.16.23	B-D1-D2-N	DC-NC	ø16 mm	2 x 95 mm ²
CEB.109.18.21	B-D1-D2-N	DC-NC	ø18 mm	2 x 50 mm ²
CEB.109.18.22	B-D1-D2-N	DC-NC	ø18 mm	2 x 70 mm ²
CEB.109.18.23	B-D1-D2-N	DC-NC	ø18 mm	2 x 95 mm ²
CEB.109.20.21	B-D1-D2-N	DC-NC	ø20 mm	2 x 50 mm ²
CEB.109.20.22	B-D1-D2-N	DC-NC	ø20 mm	2 x 70 mm ²
CEB.109.20.23	B-D1-D2-N	DC-NC	ø20 mm	2 x 95 mm ²

MAIN MATERIAL

A=Aluminium, B=Copper, D=Iron-Steel,
F=Bronze, G=Gray Cast Iron,
N=Stainless, P=Plastic, S=Brass

COATINGS

1=Electrogalvanizing, 2=Hot Dip Galvanizing, 3=Electrodeposited Copper,
4=Electrodeposited Tin, 5=Electrodeposited Chromium-Nickel,
6=Black Insulation, 7=Yellow-Green Insulation

SCREW NUT

DC=Galvanizing,
NC=Stainless,
SC=Brass

ELEKTROD BAŞLIKLARI

EARTHING ROD CONNECTORS



Code	Material Coating	Bolt	Rod Dia.	Cross Section
CEB.110.12.08	B-B4-D1-D2-N	DC-NC	ø12 mm	1x16 mm ²
CEB.110.12.09	B-B4-D1-D2-N	DC-NC	ø12 mm	1x25 mm ²
CEB.110.12.10	B-B4-D1-D2-N	DC-NC	ø12 mm	1x35 mm ²
CEB.110.12.11	B-B4-D1-D2-N	DC-NC	ø12 mm	1x50 mm ²
CEB.110.12.12	B-B4-D1-D2-N	DC-NC	ø12 mm	1x70 mm ²
CEB.110.14.08	B-B4-D1-D2-N	DC-NC	ø14 mm	1x16 mm ²
CEB.110.14.09	B-B4-D1-D2-N	DC-NC	ø14 mm	1x25 mm ²
CEB.110.14.10	B-B4-D1-D2-N	DC-NC	ø14 mm	1x35 mm ²
CEB.110.14.11	B-B4-D1-D2-N	DC-NC	ø14 mm	1x50 mm ²
CEB.110.14.12	B-B4-D1-D2-N	DC-NC	ø14 mm	1x70 mm ²
CEB.110.16.09	B-B4-D1-D2-N	DC-NC	ø16 mm	1x25 mm ²
CEB.110.16.10	B-B4-D1-D2-N	DC-NC	ø16 mm	1x35 mm ²
CEB.110.16.11	B-B4-D1-D2-N	DC-NC	ø16 mm	1x50 mm ²
CEB.110.16.12	B-B4-D1-D2-N	DC-NC	ø16 mm	1x70 mm ²
CEB.110.16.13	B-B4-D1-D2-N	DC-NC	ø16 mm	1x95 mm ²
CEB.110.18.10	B-B4-D1-D2-N	DC-NC	ø18 mm	1x35 mm ²
CEB.110.18.11	B-B4-D1-D2-N	DC-NC	ø18 mm	1x50 mm ²
CEB.110.18.12	B-B4-D1-D2-N	DC-NC	ø18 mm	1x70 mm ²
CEB.110.18.13	B-B4-D1-D2-N	DC-NC	ø18 mm	1x95 mm ²
CEB.110.18.14	B-B4-D1-D2-N	DC-NC	ø18 mm	1x120 mm ²
CEB.110.20.10	B-B4-D1-D2-N	DC-NC	ø20 mm	1x35 mm ²
CEB.110.20.11	B-B4-D1-D2-N	DC-NC	ø20 mm	1x50 mm ²
CEB.110.20.12	B-B4-D1-D2-N	DC-NC	ø20 mm	1x70 mm ²
CEB.110.20.13	B-B4-D1-D2-N	DC-NC	ø20 mm	1x95 mm ²
CEB.110.20.14	B-B4-D1-D2-N	DC-NC	ø20 mm	1x120 mm ²



Code	Material Coating	Bolt	Rod Dia.	Cross Section
CEB.112.12.08	B-B4-D1-D2-N	DC-NC	ø12 mm	1x16 mm ²
CEB.112.12.09	B-B4-D1-D2-N	DC-NC	ø12 mm	1x25 mm ²
CEB.112.12.10	B-B4-D1-D2-N	DC-NC	ø12 mm	1x35 mm ²
CEB.112.12.11	B-B4-D1-D2-N	DC-NC	ø12 mm	1x50 mm ²
CEB.112.12.12	B-B4-D1-D2-N	DC-NC	ø12 mm	1x70 mm ²
CEB.112.14.08	B-B4-D1-D2-N	DC-NC	ø14 mm	1x16 mm ²
CEB.112.14.09	B-B4-D1-D2-N	DC-NC	ø14 mm	1x25 mm ²
CEB.112.14.10	B-B4-D1-D2-N	DC-NC	ø14 mm	1x35 mm ²
CEB.112.14.11	B-B4-D1-D2-N	DC-NC	ø14 mm	1x50 mm ²
CEB.112.14.12	B-B4-D1-D2-N	DC-NC	ø14 mm	1x70 mm ²
CEB.112.16.09	B-B4-D1-D2-N	DC-NC	ø16 mm	1x25 mm ²
CEB.112.16.10	B-B4-D1-D2-N	DC-NC	ø16 mm	1x35 mm ²
CEB.112.16.11	B-B4-D1-D2-N	DC-NC	ø16 mm	1x50 mm ²
CEB.112.16.12	B-B4-D1-D2-N	DC-NC	ø16 mm	1x70 mm ²
CEB.112.16.13	B-B4-D1-D2-N	DC-NC	ø16 mm	1x95 mm ²
CEB.112.18.10	B-B4-D1-D2-N	DC-NC	ø18 mm	1x35 mm ²
CEB.112.18.11	B-B4-D1-D2-N	DC-NC	ø18 mm	1x50 mm ²
CEB.112.18.12	B-B4-D1-D2-N	DC-NC	ø18 mm	1x70 mm ²
CEB.112.18.13	B-B4-D1-D2-N	DC-NC	ø18 mm	1x95 mm ²
CEB.112.18.14	B-B4-D1-D2-N	DC-NC	ø18 mm	1x120 mm ²
CEB.112.20.10	B-B4-D1-D2-N	DC-NC	ø20 mm	1x35 mm ²
CEB.112.20.11	B-B4-D1-D2-N	DC-NC	ø20 mm	1x50 mm ²
CEB.112.20.12	B-B4-D1-D2-N	DC-NC	ø20 mm	1x70 mm ²
CEB.112.20.13	B-B4-D1-D2-N	DC-NC	ø20 mm	1x95 mm ²
CEB.112.20.14	B-B4-D1-D2-N	DC-NC	ø20 mm	1x120 mm ²

MAIN MATERIAL

A=Aluminium, B=Copper, D=Iron-Steel,
F=Bronze, G=Gray Cast Iron,
N=Stainless, P=Plastic, S=Brass

COATINGS

1=Electrogalvanizing, 2=Hot Dip Galvanizing, 3=Electrodeposited Copper,
4=Electrodeposited Tin, 5=Electrodeposited Chromium-Nickel,
6=Black Insulation, 7=Yellow-Green Insulation

SCREW NUT

DC=Galvanizing,
NC=Stainless,
SC=Brass

EARTHING ROD CONNECTORS



Code	Material Coating	Bolt	Rod Dia.	Cross Section
CEB.113.01	B-F-S	DC-NC	ø16 - 20 mm	16 - 95 mm ²



Code	Material Coating	Bolt	Rod Dia.	Cross Section
CEB.114.01	B-N	DC-NC	ø16 mm	1x50 mm ²
CEB.114.02	B-N	DC-NC	ø18 mm	1x50 mm ²
CEB.114.03	B-N	DC-NC	ø20 mm	1x50 mm ²

MAIN MATERIAL

A=Aluminium, B=Copper, D=Iron-Steel,
F=Bronze, G=Gray Cast Iron,
N=Stainless, P=Plastic, S=Brass

COATINGS

1=Electrogalvanizing, 2=Hot Dip Galvanizing, 3=Electrodeposited Copper,
4=Electrodeposited Tin, 5=Electrodeposited Chromium-Nickel,
6=Black Insulation, 7=Yellow-Green Insulation

SCREW NUT

DC=Galvanizing,
NC=Stainless,
SC=Brass

EARTHING ROD CONNECTORS



Code	Material Coating	Bolt	Çapı Rod Dia.	Cross Section
CEB.116.10	B-B4-D1-D2-N	DC-NC	ø16 mm	1x35 mm ²
CEB.116.11	B-B4-D1-D2-N	DC-NC	ø16 mm	1x50 mm ²
CEB.116.12	B-B4-D1-D2-N	DC-NC	ø16 mm	1x70 mm ²
CEB.116.13	B-B4-D1-D2-N	DC-NC	ø16 mm	1x95 mm ²
CEB.116.14	B-B4-D1-D2-N	DC-NC	ø16 mm	1x120 mm ²
CEB.118.10	B-B4-D1-D2-N	DC-NC	ø18 mm	1x35 mm ²
CEB.118.11	B-B4-D1-D2-N	DC-NC	ø18 mm	1x50 mm ²
CEB.118.12	B-B4-D1-D2-N	DC-NC	ø18 mm	1x70 mm ²
CEB.118.13	B-B4-D1-D2-N	DC-NC	ø18 mm	1x95 mm ²
CEB.118.14	B-B4-D1-D2-N	DC-NC	ø18 mm	1x120 mm ²
CEB.120.10	B-B4-D1-D2-N	DC-NC	ø20 mm	1x35 mm ²
CEB.120.11	B-B4-D1-D2-N	DC-NC	ø20 mm	1x50 mm ²
CEB.120.12	B-B4-D1-D2-N	DC-NC	ø20 mm	1x70 mm ²
CEB.120.13	B-B4-D1-D2-N	DC-NC	ø20 mm	1x95 mm ²
CEB.120.14	B-B4-D1-D2-N	DC-NC	ø20 mm	1x120 mm ²



Code	Material Coating	Bolt	Çapı Rod Dia.	Cross Section
CEB.116.20	B-B4-D1-D2-N	DC-NC	ø16 mm	2x35 mm ²
CEB.116.21	B-B4-D1-D2-N	DC-NC	ø16 mm	2x50 mm ²
CEB.116.22	B-B4-D1-D2-N	DC-NC	ø16 mm	2x70 mm ²
CEB.116.23	B-B4-D1-D2-N	DC-NC	ø16 mm	2x95 mm ²
CEB.116.24	B-B4-D1-D2-N	DC-NC	ø16 mm	2x120 mm ²
CEB.118.20	B-B4-D1-D2-N	DC-NC	ø18 mm	2x35 mm ²
CEB.118.21	B-B4-D1-D2-N	DC-NC	ø18 mm	2x50 mm ²
CEB.118.22	B-B4-D1-D2-N	DC-NC	ø18 mm	2x70 mm ²
CEB.118.23	B-B4-D1-D2-N	DC-NC	ø18 mm	2x95 mm ²
CEB.118.24	B-B4-D1-D2-N	DC-NC	ø18 mm	2x120 mm ²
CEB.120.20	B-B4-D1-D2-N	DC-NC	ø20 mm	2x35 mm ²
CEB.120.21	B-B4-D1-D2-N	DC-NC	ø20 mm	2x50 mm ²
CEB.120.22	B-B4-D1-D2-N	DC-NC	ø20 mm	2x70 mm ²
CEB.120.23	B-B4-D1-D2-N	DC-NC	ø20 mm	2x95 mm ²
CEB.120.24	B-B4-D1-D2-N	DC-NC	ø20 mm	2x120 mm ²

MAIN MATERIAL

A=Aluminium, B=Copper, D=Iron-Steel, F=Bronze, G=Gray Cast Iron, N=Stainless, P=Plastic, S=Brass

COATINGS

1=Electrogalvanizing, 2=Hot Dip Galvanizing, 3=Electrodeposited Copper, 4=Electrodeposited Tin, 5=Electrodeposited Chromium-Nickel, 6=Black Insulation, 7=Yellow-Green Insulation

SCREW NUT

DC=Galvanizing, NC=Stainless, SC=Brass

EARTHING ROD CONNECTORS



Code	Material Coating	Bolt	Rod Dia.	Size
CEB.201.16.01	B-D1-D2-N	DC-NC	ø16 mm	25x3 mm
CEB.201.16.02	B-D1-D2-N	DC-NC	ø16 mm	30x3 mm
CEB.201.16.03	B-D1-D2-N	DC-NC	ø16 mm	40x3 mm
CEB.201.18.01	B-D1-D2-N	DC-NC	ø18 mm	25x3 mm
CEB.201.18.02	B-D1-D2-N	DC-NC	ø18 mm	30x3 mm
CEB.201.18.03	B-D1-D2-N	DC-NC	ø18 mm	40x3 mm
CEB.201.20.01	B-D1-D2-N	DC-NC	ø20 mm	25x3 mm
CEB.201.20.02	B-D1-D2-N	DC-NC	ø20 mm	30x3 mm
CEB.201.20.03	B-D1-D2-N	DC-NC	ø20 mm	40x3 mm

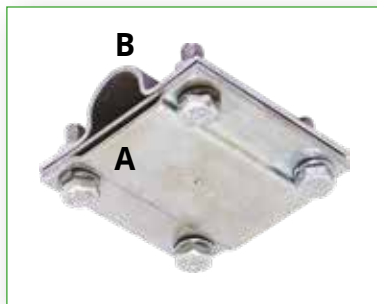

Code	Material Coating	Bolt	Rod Dia.	A- Size
CEB.202.16.01	B-D1-D2-N	DC-NC	ø16 mm	25x3 mm
CEB.202.16.02	B-D1-D2-N	DC-NC	ø16 mm	30x3 mm
CEB.202.16.03	B-D1-D2-N	DC-NC	ø16 mm	40x3 mm
CEB.202.18.01	B-D1-D2-N	DC-NC	ø18 mm	25x3 mm
CEB.202.18.02	B-D1-D2-N	DC-NC	ø18 mm	30x3 mm
CEB.202.18.03	B-D1-D2-N	DC-NC	ø18 mm	40x3 mm
CEB.202.20.01	B-D1-D2-N	DC-NC	ø20 mm	25x3 mm
CEB.202.20.02	B-D1-D2-N	DC-NC	ø20 mm	30x3 mm
CEB.202.20.03	B-D1-D2-N	DC-NC	ø20 mm	40x3 mm

MAIN MATERIAL

A=Aluminium, B=Copper, D=Iron-Steel,
F=Bronze, G=Gray Cast Iron,
N=Stainless, P=Plastic, S=Brass

COATINGS

1=Electrogalvanizing, 2=Hot Dip Galvanizing, 3=Electrodeposited Copper,
4=Electrodeposited Tin, 5=Electrodeposited Chromium-Nickel,
6=Black Insulation, 7=Yellow-Green Insulation

SCREW NUT

DC=Galvanizing,
NC=Stainless,
SC=Brass

EARTHING IMPROVEMENT COMPOUND - REM

REM was developed in 2003.

It is a highly conductive casing material that solves your most difficult grounding problems.

REM increases soil conductivity in all soil types.

It is ideal for soils with poor conductivity, such as rocky areas, mountain peaks, and sandy soil.

REM is the solution for situations where grounding rods cannot be used.

It also eliminates the problems associated with limited space.

No other material can reduce soil resistance as effectively as REM and maintain it at a consistently low resistance.

No other system can maintain the lifespan of a grounding system with high conductivity as long as REM.

REM's performance has been proven through rigorous testing using state-of-the-art technology and reinforced by the trust it commands in its field.

Effect of REM

- It reduces the soil's resistance.
- Once installed, it maintains the resistance constant for the life of the system.
- It works in all soil types.
- REM is a very effective casing material.
- It does not dissolve or deteriorate over time.
- It increases frost resistance by 10%.
- There is no need for periodic inspections or renewals.
- There is no need for maintenance.
- It does not matter whether the environment is dry or humid.

REM is easy to use

- It's easy to transport in 10 kg bags.
- One person is sufficient for installation.
- It doesn't matter whether the soil is wet or dry.
- When used dry, there's no need to mix.

Simply open and pour.

- When used dry, it immediately absorbs humidity from the soil.
- It reduces the area to be grounded.
- It reduces the use of grounding electrodes.
- It reduces grounding costs.

REM is environmentally friendly

- It has no effect on the soil.
- It does not pollute groundwater.

Resistance Characters - Resistance (OHM-CM)



EARTHING IMPROVEMENT COMPOUND - REM

REM Bentonite Clay

As the graph shows, REM's resistance is 20 times lower than the other.

RADSAN's experienced technical staff is ready to assist you and answer your questions.

Do your next job with REM

And take advantage of REM's long-lasting benefits of lower resistance and higher conductivity.

REM is absolutely reliable and the best.

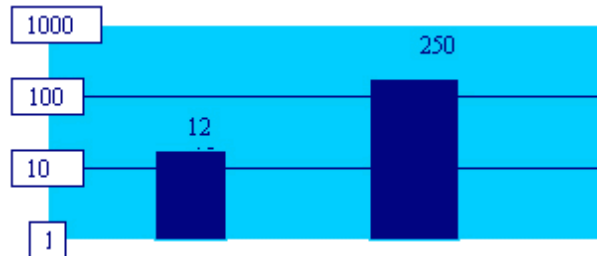

Explanations

- REM is a continuous and maintenance-free system.
- It does not lose its effectiveness over time.
- REM can be used on both dry soil and wet ground.
- It does not lose any conductivity when in constant contact with water.
- The soil resistivity where REM is used does not exceed 20 ohm-cm.
- REM does not cause galvanic corrosion with electrodes such as coal added to the soil to reduce grounding resistance.
- REM does not cause acidic reactions with electrodes such as salt added to the soil to reduce grounding resistance.

Implementation of REM

GROUNDING CHANNEL APPLICATION WITH HORIZONTAL GROUNDING CONDUCTOR

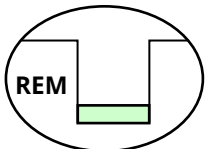

1. Dig a channel 10.2 cm wide and 76.2 cm deep (4 x 30 inches) or down to the frost line (usually deeper than DIMENSIONS). Fill the bottom with 2.5 cm (1 inch) of REM.

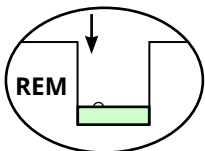

2. Place the conductor on top of the REM.

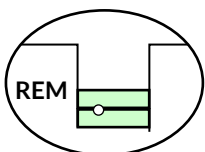

3. Pour the same amount of REM onto the conductor (make sure the conductor is completely covered).



4. Fill it with 10.2 cm (4 inches) of soil.

EARTHING IMPROVEMENT COMPOUND

The table below shows the values for different types of channels.

APPROXIMATE LENGTH OF GROUNDING CONDUCTOR THAT 1 BAG OF REM WILL COVER IN THE CHANNEL				
	WIDTH OF THE CHANNEL		TOTAL THICKNESS OF REM	
	1" (2,5 cm)	2" (5,1 cm)	3" (7,6 cm)	4" (10,2 cm)
4" (10,2cm)	14,0'(4.3m)	7,0'(2.1m)	4,7'(1.4m)	3,5'(1.1m)
6" (15,2cm)	9,3'(2.8m)	4,7'(1.4m)	3,1'(0.9m)	2,3'(0.7m)
8" (20,3cm)	7,0'(2.1m)	3,5'(1.1m)	2,3'(0.7m)	1,8'(0.5m)
10" (25,4cm)	5,6'(1.7m)	2,8'(0.9m)	1,9'(0.6m)	1,4'(0.4m)
12" (30,5cm)	4,7'(1.4m)	2,3'(0.7m)	1,6'(0.5m)	1,2'(0.4m)

Half of this thickness should be applied under the conductor and half on it.

APPLICATION MOUNTING WITH GROUNDING ROD

- 7.6 cm. (3 inç) or more widely (6 inç) and ground rod length 15,2 cm. a hole of less depth is drilled.
- Çubuğu deliğe yerleştirin 1 foot kadar (30 cm) dike çakın. (Eğer mümkünse çubuğun tepesi deliğin V ucundan 15.2 cm. (6 inç) daha aşağıda olması gerekir.) Sonra çubuğu cadweld ürünlerini kullanarak istediğiniz bütün For mounting onları yapabilirsiniz.
- Gerekli miktardaki REM' i (tablo 2) deliğe dökün.REM' in çubuğun çevresinin iyice dolduğundan emin olun.
- Geri kalan boşluğu toprakla doldurun.

NOT: Delikte biriken su işlemiden önce boşaltılmalıdır. REM, Humidityli olarak kullanılmak istenirse standart, çimento karıştırıcı gibi alışılmış aletleri kullanabilirsiniz. 1 torba REM için 5.7-7.6 litre (3/2, 2 galon) su kullanınız. (tablo 2)

1 TORBA REM'in DOLDURACAĞI TAHMİNİ DERİNLİK (Yoğunluk 1442 kg/ m ³)							
ÇUKURUN ÇAPI	ÇUKUR DERİNLİĞİ						
	6'(1,8m)	7'(2,1m)	8'(2,4m)	9'(2,7m)	17'(5,2)m	18'(5,8m)	20'(6,1m)
3"(7,6cm)	2	2	2	2	4	4	4
4"(10,2cm)	2	3	3	3	6	7	7
5"(10,2cm)	3	4	4	5	9	10	10
6"(15,2cm)	5	5	6	7	13	14	15
7"(17,8cm)	6	7	8	9	17	19	20
8"(20,3cm)	8	9	11	12	22	25	26
9"(22,9cm)	10	12	13	15	28	31	32
10"(25,4cm)	12	14	16	18	34	38	40

MAIN MATERIAL

A=Aluminium, B=Copper, D=Iron-Steel, F=Bronze, G=Gray Cast Iron, N=Stainless, P=Plastic, S=Brass

COATINGS

1=Electrogalvanizing, 2=Hot Dip Galvanizing, 3=Electrodeposited Copper, 4=Electrodeposited Tin, 5=Electrodeposited Chromium-Nickel, 6=Black Insulation, 7=Yellow-Green Insulation

SCREW NUT

DC=Galvanizing, NC=Stainless, SC=Brass

TOPRAKLAMA PRİZLERİ

EARTHING POINTS



Kod Code	Material/Coating	Çap Dia	A Diş A Thread
ELT-101.10	B-D1-D2-N-F	20 mm	M12
ELT-101.11	B-D1-D2-N-F	40 mm	M12



Kod Code	Material/Coating	Boyut Size
B.165.01	S-F	65x85 mm



Kod Code	Material/Coating	Boyut Size
B.165.02	S-F	98x159 mm



Kod Code	Material/Coating	Boyut Size
B168.01	S-F	121x185 mm

MAIN MATERIAL

A=Aluminium, B=Copper, D=Iron-Steel,
F=Bronze, G=Gray Cast Iron,
N=Stainless, P=Plastic, S=Brass

COATINGS

1=Electrogalvanizing, 2=Hot Dip Galvanizing, 3=Electrodeposited Copper,
4=Electrodeposited Tin, 5=Electrodeposited Chromium-Nickel,
6=Black Insulation, 7=Yellow-Green Insulation

SCREW NUT

DC=Galvanizing,
NC=Stainless,
SC=Brass

EARTHING POINTS



Code	Material/Coating	Thread
DB.8	S	M8
DB.10	S	M10
DB.12	S	M12
DB.16	S	M14



Code	Material/Coating	Thread
B.162.12	S	2 x M12
B.164.12	S	4 x M12



Code	Material/Coating	Connection Type
GPS.01	D1-N-B-S	Çap 20 mm
GPS.02	D1-N-B-S	Çap 8 mm
GPS.03	D1-N-B-S	Çap ≤12 mm

MAIN MATERIAL

A=Aluminium, B=Copper, D=Iron-Steel,
F=Bronze, G=Gray Cast Iron,
N=Stainless, P=Plastic, S=Brass

COATINGS

1=Electrogalvanizing, 2=Hot Dip Galvanizing, 3=Electrodeposited Copper,
4=Electrodeposited Tin, 5=Electrodeposited Chromium-Nickel,
6=Black Insulation, 7=Yellow-Green Insulation

SCREW NUT

DC=Galvanizing,
NC=Stainless,
SC=Brass

HELICOPTER GROUNDING DETAIL

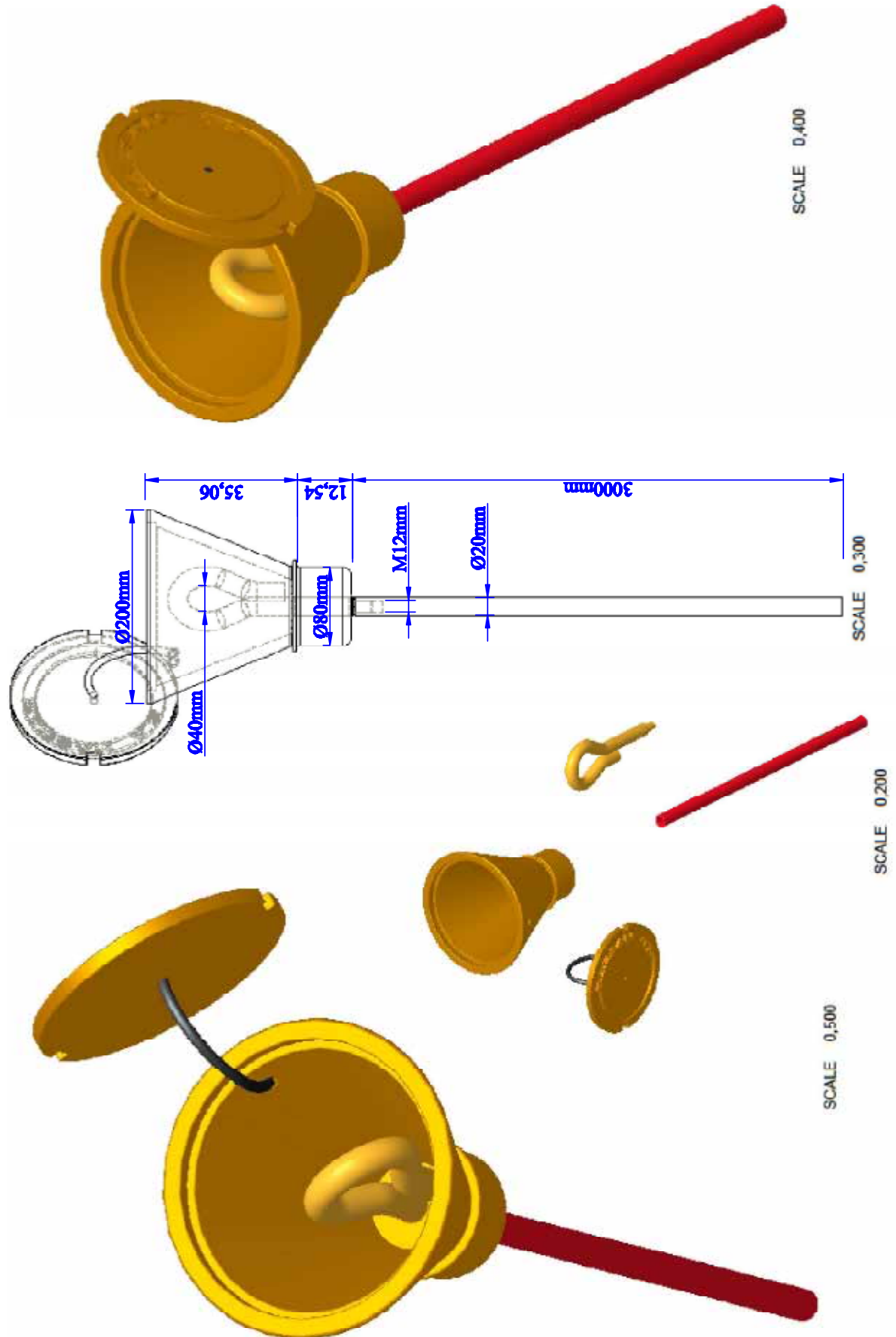

BARS

Main Bars



Code	Material Coating	Size	Hole Dia.	
EB.101	A-B-B4-D1-D2	25x3 mm	30 cm.	M8
	A-B-B4-D1-D2	25x3 mm	40 cm.	M8
	A-B-B4-D1-D2	25x3 mm	50 cm.	M8
	A-B-B4-D1-D2	30x3 mm	30 cm.	M8
	A-B-B4-D1-D2	30x3 mm	40 cm.	M8
	A-B-B4-D1-D2	30x3 mm	50 cm.	M8
	A-B-B4-D1-D2	30x5 mm	30 cm.	M8
	A-B-B4-D1-D2	30x5 mm	40 cm.	M8
	A-B-B4-D1-D2	30x5 mm	50 cm.	M8
	A-B-B4-D1-D2	40x5 mm	30 cm.	M8
	A-B-B4-D1-D2	40x5 mm	40 cm.	M8
	A-B-B4-D1-D2	40x5 mm	50 cm.	M8

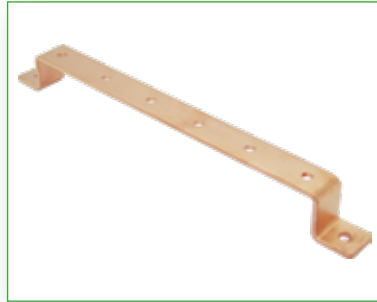

Code	Material Coating	Size	Hole Dia.	
EBA.101	A-B-B4-D1-D2	25x3 mm	30 cm.	M8
	A-B-B4-D1-D2	25x3 mm	40 cm.	M8
	A-B-B4-D1-D2	25x3 mm	50 cm.	M8
	A-B-B4-D1-D2	30x3 mm	30 cm.	M8
	A-B-B4-D1-D2	30x3 mm	40 cm.	M8
	A-B-B4-D1-D2	30x3 mm	50 cm.	M8
	A-B-B4-D1-D2	30x5 mm	30 cm.	M8
	A-B-B4-D1-D2	30x5 mm	40 cm.	M8
	A-B-B4-D1-D2	30x5 mm	50 cm.	M8
	A-B-B4-D1-D2	40x5 mm	30 cm.	M8
	A-B-B4-D1-D2	40x5 mm	40 cm.	M8
	A-B-B4-D1-D2	40x5 mm	50 cm.	M8



Code	Material Coating	Size	Hole Dia.	
EB.102	A-B-B4-D1-D2	40x5 mm	30 cm.	M8
	A-B-B4-D1-D2	40x5 mm	40 cm.	M8
	A-B-B4-D1-D2	40x5 mm	50 cm.	M8
	A-B-B4-D1-D2	50x5 mm	30 cm.	M8
	A-B-B4-D1-D2	50x5 mm	40 cm.	M8
	A-B-B4-D1-D2	50x5 mm	50 cm.	M8
	A-B-B4-D1-D2	60x5 mm	30 cm.	M8
	A-B-B4-D1-D2	60x5 mm	40 cm.	M8
	A-B-B4-D1-D2	60x5 mm	50 cm.	M8

MAIN MATERIAL

A=Aluminium, B=Copper, D=Iron-Steel,
F=Bronze, G=Gray Cast Iron,
N=Stainless, P=Plastic, S=Brass

COATINGS

1=Electrogalvanizing, 2=Hot Dip Galvanizing, 3=Electrodeposited Copper,
4=Electrodeposited Tin, 5=Electrodeposited Chromium-Nickel,
6=Black Insulation, 7=Yellow-Green Insulation

SCREW NUT

DC=Galvanizing,
NC=Stainless,
SC=Brass

BARS



Code	Material Coating	Size	Hole Dia.	
EBA.102	A-B-B4-D1-D2	40x5 mm	30 cm.	M8
	A-B-B4-D1-D2	40x5 mm	40 cm.	M8
	A-B-B4-D1-D2	40x5 mm	50 cm.	M8
	A-B-B4-D1-D2	50x5 mm	30 cm.	M8
	A-B-B4-D1-D2	50x5 mm	40 cm.	M8
	A-B-B4-D1-D2	50x5 mm	50 cm.	M8
	A-B-B4-D1-D2	60x5 mm	30 cm.	M8
	A-B-B4-D1-D2	60x5 mm	40 cm.	M8
	A-B-B4-D1-D2	60x5 mm	50 cm.	M8

Earthing Bars with Insulators

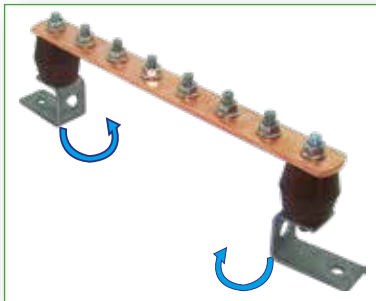

Code	Material Coating	Size	
EB.200	A-B-B4-D1-D2	25x3 mm	30 cm
	A-B-B4-D1-D2	25x3 mm	40 cm
	A-B-B4-D1-D2	25x3 mm	50 cm
	A-B-B4-D1-D2	30x3 mm	30 cm
	A-B-B4-D1-D2	30x3 mm	40 cm
	A-B-B4-D1-D2	30x3 mm	50 cm
	A-B-B4-D1-D2	30x5 mm	30 cm
	A-B-B4-D1-D2	30x5 mm	40 cm
	A-B-B4-D1-D2	30x5 mm	50 cm
	A-B-B4-D1-D2	40x5 mm	30 cm
	A-B-B4-D1-D2	40x5 mm	40 cm
	A-B-B4-D1-D2	40x5 mm	50 cm
	A-B-B4-D1-D2	50x5 mm	30 cm
	A-B-B4-D1-D2	50x5 mm	40 cm
	A-B-B4-D1-D2	50x5 mm	50 cm



Code	Material Coating	Size	
EBK.200	A-B-B4-D1-D2	25x3 mm	30 cm
	A-B-B4-D1-D2	25x3 mm	40 cm
	A-B-B4-D1-D2	25x3 mm	50 cm
	A-B-B4-D1-D2	30x3 mm	30 cm
	A-B-B4-D1-D2	30x3 mm	40 cm
	A-B-B4-D1-D2	30x3 mm	50 cm
	A-B-B4-D1-D2	30x5 mm	30 cm
	A-B-B4-D1-D2	30x5 mm	40 cm
	A-B-B4-D1-D2	30x5 mm	50 cm
	A-B-B4-D1-D2	40x5 mm	30 cm
	A-B-B4-D1-D2	40x5 mm	40 cm
	A-B-B4-D1-D2	40x5 mm	50 cm
	A-B-B4-D1-D2	50x5 mm	30 cm
	A-B-B4-D1-D2	50x5 mm	40 cm
	A-B-B4-D1-D2	50x5 mm	50 cm

MAIN MATERIAL

A=Aluminium, B=Copper, D=Iron-Steel,
F=Bronze, G=Gray Cast Iron,
N=Stainless, P=Plastic, S=Brass

COATINGS

1=Electrogalvanizing, 2=Hot Dip Galvanizing, 3=Electrodeposited Copper,
4=Electrodeposited Tin, 5=Electrodeposited Chromium-Nickel,
6=Black Insulation, 7=Yellow-Green Insulation

SCREW NUT

DC=Galvanizing,
NC=Stainless,
SC=Brass

BARS

Disconnection Links

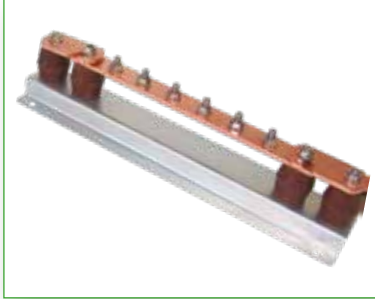

Code	Material/Coating	Size	
EB.202	A-B-B4-D1-D2	30x5 mm	40 cm
	A-B-B4-D1-D2	30x5 mm	50 cm
	A-B-B4-D1-D2	30x5 mm	60 cm
	A-B-B4-D1-D2	30x5 mm	80 cm
	A-B-B4-D1-D2	30x5 mm	100 cm
	A-B-B4-D1-D2	40x5 mm	40 cm
	A-B-B4-D1-D2	40x5 mm	50 cm
	A-B-B4-D1-D2	40x5 mm	60 cm
	A-B-B4-D1-D2	40x5 mm	80 cm
	A-B-B4-D1-D2	40x5 mm	100 cm
	A-B-B4-D1-D2	50x5 mm	40 cm
	A-B-B4-D1-D2	50x5 mm	50 cm
	A-B-B4-D1-D2	50x5 mm	60 cm
	A-B-B4-D1-D2	50x5 mm	80 cm
	A-B-B4-D1-D2	50x5 mm	100 cm
	A-B-B4-D1-D2	60x5 mm	40 cm
	A-B-B4-D1-D2	60x5 mm	50 cm
	A-B-B4-D1-D2	60x5 mm	60 cm
	A-B-B4-D1-D2	60x5 mm	80 cm
	A-B-B4-D1-D2	60x5 mm	100 cm

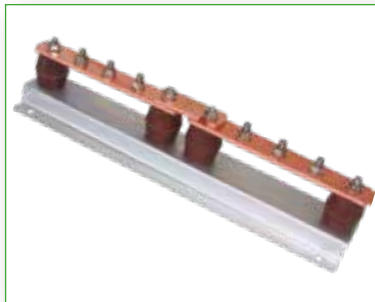

Code	Material/Coating	Size	
EBT.201	A-B-B4-D1-D2	30x5 mm	40 cm
	A-B-B4-D1-D2	30x5 mm	50 cm
	A-B-B4-D1-D2	30x5 mm	60 cm
	A-B-B4-D1-D2	30x5 mm	80 cm
	A-B-B4-D1-D2	30x5 mm	100 cm
	A-B-B4-D1-D2	40x5 mm	40 cm
	A-B-B4-D1-D2	40x5 mm	50 cm
	A-B-B4-D1-D2	40x5 mm	60 cm
	A-B-B4-D1-D2	40x5 mm	80 cm
	A-B-B4-D1-D2	40x5 mm	100 cm
	A-B-B4-D1-D2	50x5 mm	40 cm
	A-B-B4-D1-D2	50x5 mm	50 cm
	A-B-B4-D1-D2	50x5 mm	60 cm
	A-B-B4-D1-D2	50x5 mm	80 cm
	A-B-B4-D1-D2	50x5 mm	100 cm
	A-B-B4-D1-D2	60x5 mm	40 cm
	A-B-B4-D1-D2	60x5 mm	50 cm
	A-B-B4-D1-D2	60x5 mm	60 cm
	A-B-B4-D1-D2	60x5 mm	80 cm
	A-B-B4-D1-D2	60x5 mm	100 cm

MAIN MATERIAL

A=Aluminium, B=Copper, D=Iron-Steel,
F=Bronze, G=Gray Cast Iron,
N=Stainless, P=Plastic, S=Brass

COATINGS

1=Electrogalvanizing, 2=Hot Dip Galvanizing, 3=Electrodeposited Copper,
4=Electrodeposited Tin, 5=Electrodeposited Chromium-Nickel,
6=Black Insulation, 7=Yellow-Green Insulation

SCREW NUT

DC=Galvanizing,
NC=Stainless,
SC=Brass

BARS

Disconnection Links



Code	Material/Coating	Size	
EBT.202	B-B4-D1-D2	30x5 mm	40 cm
	B-B4-D1-D2	30x5 mm	50 cm
	B-B4-D1-D2	30x5 mm	60 cm
	B-B4-D1-D2	30x5 mm	80 cm
	B-B4-D1-D2	30x5 mm	100 cm
	B-B4-D1-D2	40x5 mm	40 cm
	B-B4-D1-D2	40x5 mm	50 cm
	B-B4-D1-D2	40x5 mm	60 cm
	B-B4-D1-D2	40x5 mm	80 cm
	B-B4-D1-D2	40x5 mm	100 cm
	B-B4-D1-D2	50x5 mm	40 cm
	B-B4-D1-D2	50x5 mm	50 cm
	B-B4-D1-D2	50x5 mm	60 cm
	B-B4-D1-D2	50x5 mm	80 cm
	B-B4-D1-D2	50x5 mm	100 cm
	B-B4-D1-D2	60x5 mm	40 cm
	B-B4-D1-D2	60x5 mm	50 cm
	B-B4-D1-D2	60x5 mm	60 cm
	B-B4-D1-D2	60x5 mm	80 cm
	B-B4-D1-D2	60x5 mm	100 cm



Code	Description	Size		Bolt
TSIC -101	<i>SINGLE ROW HOLE BAR, WITH INSULATORS, COVERED</i>	30x3 mm	300 mm	NC
		30x3 mm	500 mm	NC
		30x3 mm	1000 mm	NC
		50x5 mm	300 mm	NC
		50x5 mm	500 mm	NC
		50x5 mm	1000 mm	NC
		100x10 mm	300 mm	NC
		100x10 mm	500 mm	NC
		100x10 mm	1000 mm	NC

MAIN MATERIAL

A=Aluminium, B=Copper, D=Iron-Steel,
F=Bronze, G=Gray Cast Iron,
N=Stainless, P=Plastic, S=Brass

COATINGS

1=Electrogalvanizing, 2=Hot Dip Galvanizing, 3=Electrodeposited Copper,
4=Electrodeposited Tin, 5=Electrodeposited Chromium-Nickel,
6=Black Insulation, 7=Yellow-Green Insulation

SCREW NUT

DC=Galvanizing,
NC=Stainless,
SC=Brass

BARS



Code	Description	Size		Bolt
DSIC 201	DOUBLE ROW HOLE BAR , WITH INSULATORS, COVERED	50x5 mm	300 mm	NC
		50x5 mm	500 mm	NC
		50x5 mm	1000 mm	NC
		100x10 mm	200 mm	NC
		100x10 mm	300 mm	NC
		100x10 mm	400 mm	NC
		100x10 mm	500 mm	NC
		100x10 mm	1000 mm	NC
		160x10 mm	300 mm	NC
		160x10 mm	500 mm	NC
		160x10 mm	1000 mm	NC

Signal Bars



Code	Material/Coating	Bolt	Size
EBH-101.02	D1-D2-S-S4-N	DC-NC	20x15x175 mm

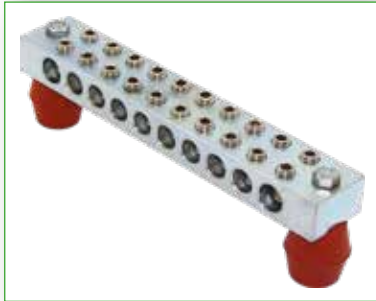

Code	Material/Coating	Bolt	Size
EBH-101.03	D1-D2-S-S4-N	DC-NC	20x15x175 mm

Insulators



Code	Description	Thread
B.2.01	1 KV	2 Screw-in
B.2.02		1 Screw-in
B.2.03		Screwless

MAIN MATERIAL

A=Aluminium, B=Copper, D=Iron-Steel, F=Bronze, G=Gray Cast Iron, N=Stainless, P=Plastic, S=Brass

COATINGS

1=Electrogalvanizing, 2=Hot Dip Galvanizing, 3=Electrodeposited Copper, 4=Electrodeposited Tin, 5=Electrodeposited Chromium-Nickel, 6=Black Insulation, 7=Yellow-Green Insulation

SCREW NUT

DC=Galvanizing, NC=Stainless, SC=Brass

EARTHING DRUMS



Code	Material	Description	Size
ESD-101.01	D-B-N	Tambur (Küçük)	20 m
ESD-101.02	D-B-N	Tambur (Büyük)	20 m

Earthing Panels



Code	Material	Description
ESDP-102.01	N,painted steel	Grounding panel with small rotating drum and concrete base
ESDP-102.02	N,painted steel	Grounding panel with small rotating drum without concrete base
ESDP-102.03	N,painted steel	Grounding panel with big rotating drum and concrete base
ESDP-102.04	N,painted steel	Grounding panel with big rotating drum without concrete base

ESD Earthing Kit



Code	Material	Rod Height
ESD.100.01	D1-D2-B-B4-N	1 m

Earthing Cable with Metallic Clip



Code	Description	Length
RST.01.01	16 mm ² NYAF kablo	5 m
RST.01.02	16 mm ² NYAF kablo	10 m
RST.01.03	16 mm ² NYAF kablo	20 m
RST.01.04	25 mm ² NYAF kablo	5 m
RST.01.05	25 mm ² NYAF kablo	10 m
RST.01.06	25 mm ² NYAF kablo	20 m
RST.01.07	35 mm ² NYAF kablo	5 m
RST.01.08	35 mm ² NYAF kablo	10 m
RST.01.09	35 mm ² NYAF kablo	20 m

MAIN MATERIAL

A=Aluminium, B=Copper, D=Iron-Steel, F=Bronze, G=Gray Cast Iron, N=Stainless, P=Plastic, S=Brass

COATINGS

1=Electrogalvanizing, 2=Hot Dip Galvanizing, 3=Electrodeposited Copper, 4=Electrodeposited Tin, 5=Electrodeposited Chromium-Nickel, 6=Black Insulation, 7=Yellow-Green Insulation

SCREW NUT

DC=Galvanizing, NC=Stainless, SC=Brass

STATIC EARTHING PLATES



Code	Material/Coating	Size
ELT-104.01	B4-B-N	250 x 250 x 2 mm
ELT-104.02	B4-B-N	400 x 400 x 2 mm



Code	Material/Coating	Size
ELT-105.01	B-B4-N	400 x 400 mm
ELT-105.02	B-B4-N	250 x 250 mm

ESD Empedans / ESD Impedance



Code	Description	Material Coating	up to Cond. Dia
ELTR-100.01	1MΩ Empedanslı Impedance	S	8 mm

MAIN MATERIAL

A=Aluminium, B=Copper, D=Iron-Steel, F=Bronze, G=Gray Cast Iron, N=Stainless, P=Plastic, S=Brass

COATINGS

1=Electrogalvanizing, 2=Hot Dip Galvanizing, 3=Electrodeposited Copper, 4=Electrodeposited Tin, 5=Electrodeposited Chromium-Nickel, 6=Black Insulation, 7=Yellow-Green Insulation

SCREW NUT

DC=Galvanizing, NC=Stainless, SC=Brass

Concrete Earthing Pit



Code	Weight	Size	Thickness Size
RIP.101.01.01	55 kg (Kapaksız)	40x40xh25 cm	5 cm
RIP.101.01.16	60 kg (Kapaksız)	40x40xh40 cm	5 cm
RIP.101.01.07	230 kg (Kapaksız)	50x60xh60 cm	5 cm

Covers: You can request options such as concrete, cast iron, hot-dip galvanized, or iron.



Code	Weight	Size	Thickness Size
RIP.101.06.03	210 kg (Kapaksız)	60x60xh40 cm	10 cm

Covers: You can request options such as concrete, cast iron, hot-dip galvanized, or iron.

Plastic Earthing Pit



Code	Size
RIP.101.06.02	30x30x30 cm
RIP.101.06.01	40x40x40 cm
RIP.101.05.01	55x55x50 cm

Hot Dip Galvanized or Electro Galvanized Earthing Pit



Code	Weight	Size
RIP.101.02	13 kg / 20 kg	40x40x40 / 50x50x50

Casting Earthing Pit



Kod Code	Ağırlık Weight	Ölçü Size	Kalınlık Thickness Size
RIP.101.03	13 kg	22.8x13.8xh20 cm	33 cm

MAIN MATERIAL

A=Aluminium, B=Copper, D=Iron-Steel,
F=Bronze, G=Gray Cast Iron,
N=Stainless, P=Plastic, S=Brass

COATINGS

1=Electrogalvanizing, 2=Hot Dip Galvanizing, 3=Electrodeposited Copper,
4=Electrodeposited Tin, 5=Electrodeposited Chromium-Nickel,
6=Black Insulation, 7=Yellow-Green Insulation

SCREW NUT

DC=Galvanizing,
NC=Stainless,
SC=Brass

EARTHING MEASUREMENT DEVICES

ERT-S



Features

- 1- Grounding Resistance Test.
- 2- Soil Specific Resistance Test.
- 3- Optional grounding resistance test without stakes using a measuring probe.
- 4- Transferring measurement values to a computer.
- 5- Factory calibration certificate.

Metrel Euro Test



Features

- 1- Grounding resistance test (with stakes).
- 2- Grounding resistance test (without stakes).
- 3- Soil Specific Resistance Test.
- 4- Insulation, RCD (Residual Current Device), Phase Sequence, Varistor, PE Grounding Line Continuity, Loop and Line Impedance Test.
- 5- Power-Harmonic, Phase Angle-Frequency-Contact Voltage, Illuminance, K Leakage Current, Current, Voltage, KW, VA, Var, CosQ Measurements.
- 6- Transferring measurement values to a computer.

DT-5300B



Features

- 1- Grounding Resistance Test.
- 2- Soil Specific Resistance Test.
- 3- Factory calibration certificate.

EXOTHERMIC WELDING SYSTEMS
CADWELD®



ERICO TURKEY REPRESENTATIVE

WHAT IS EXOTHERMIC SOURCE?



Reactions that release heat during their occurrence are called exothermic reactions. The high heat generated as a result of this reaction permanently bonds the molten metal powders and conductors together.



It was developed in 1938 by Dr. Charles Cadwell in Ohio, USA.

Long-Lasting, Permanent Connection



Provides permanent mounting on at the molecular level, ensuring stability underground, under load, and in corrosive environments. No loosening occurs over time at the attachment point. Achieves a service life as long as the installation itself.

Long-Lasting, Permanent Connection



It creates a homogeneous current path and can carry as much current as the conductors it connects. The contact resistance is negligible.

IEEE 837 CURRENT TEST

The Only Method That Can Weld Different Metals Together



Easy and Fast

- Anyone can do it with simple training.
- No external power source required.
- Easy and quick to build.



QUALITY

Powder Quality

- The purity and homogeneity of the powders in the powder mixture are critical factors affecting weld quality.
- Using scrap or recycled powders instead of pure powders results in incomplete, spiked welds.
- Inadequately mixed powders prevent heat from forming homogeneously, causing the weld zone to fill unevenly and creating more thermal effects on a conductor.
- Low-quality powders easily become damp on site and fail to ignite.

Crucible Quality

If the appropriate type and quality of crucible raw material is not used:

- Molten metal cannot flow smoothly through the channels and cannot properly fill the welding chamber.
- The crucible cannot cool quickly and evenly.
- If not manufactured with precision, the crucible will be damaged by the molten metal and the resulting pressure.
- The crucible's life will be very short.

Why High Quality?

- Using low-quality casing material causes work delays.
- The molecular bonding required for mounting does not occur sufficiently; contact resistance increases.
- Corrosion occurs due to gaps between conductors.
- If quality control is not performed on the joints, defective joints cannot be detected.
- The pot deforms very quickly and leads to additional costs.
 - Labor costs increase,
 - Dust consumption increases,
 - Pot consumption increases.

CADWELD CLASSIC



- The powder sources are contained in tubes.
- Gunpowder is located at the bottom of the tubes.
- The powder mixture is of the highest purity.
- The powder mixture is homogeneous.

4 STEPS AFTER CRUCIBLE INSTALLATION



Empty the Dust



Empty the Gunpowder



Light your lighter



Open the crucible

CADWELD PLUS



Welding powders and gunpowder are contained in sealed capsules.

- The powder mixture is of the highest purity.
- The powder mixture is homogeneous.
- Since the capsule remains unopened, welding is performed with the correct amount.
- Production time is 30% shorter.
- Can be stored for a very long time. Does not absorb moisture.
- It is safe for use. Welding is performed from a distance of 1 meter.

4 STEPS AFTER SETTING UP THE CRUCIBLE



Place the Plus Powder in Place



Put the Plus Lighter On



Open the Crucible

AKSESUARLAR



Cadweld Classic



Crucible



Cadweld Plus



Classic Lighter



Electronic Cigarette Lighter



Putty







Scraper



Brush

QUALITY CONTROL

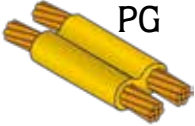

Supplement Shapes	Conductor Cross Section		Thermoweld Dimensions	Pliers Type	Code
	A (mm ²)	B (mm ²)			
 SS	50 (8mm round)	50 (8mm round)	45	L-160	SSC-W6
	70 (10mm round)	70 (10mm round)	65	L-160	SSC-W8
	25	25	32	L-160	SSC-Y1
	35	35	32	L-160	SSC-Y2
	50	50	45	L-160	SSC-Y3
	70	70	65	L-160	SSC-Y4
	95	95	90	L-160	SSC-Y5
	120	120	115	L-160	SSC-Y6
 TA	25	25	32	L-160	TAC-Y1
	35	35	45	L-160	TAC-Y2
	35	25	45	L-160	TAC-Y2-Y1
	50	50	90	L-160	TAC-Y3
	8mm round	8mm round	65	L-160	TAC-W6
	70	70	90	L-160	TAC-Y4
	70	35	45	L-160	TAC-Y4-Y2
	95	95	115	L-160	TAC-Y5
	95	120	150	L-160	TAC-Y5-Y6
	120	120	150	L-160	TAC-Y6
	120	70	90	L-160	TAC-Y6-Y4
	150	150	200	L-160	TAC-Y7
	185	185	200	L-160	TAC-Y8
 XA	25	25	45	L-160	XAC-Y1
	35	35	65	L-160	XAC-Y2
	50	50	90	L-160	XAC-Y3
	8mm round	8mm round	65	L-160	XAC-W6
	70	70	115	L-160	XAC-Y4
	95	95	150	L-160	XAC-Y5
	120	120	200	L-160	XAC-Y6
 XBD	50	50	115	L-160	XBC-Y3-Y3
	95	95	250	L-160	XBC-Y5-Y5
	120	120	2x150	L-160	XBQ-Y6-Y6
 PG	25	25	45	L-160	PGC-Y1
	35	35	65	L-160	PGC-Y2
	50	50	90	L-160	PGC-Y3
	8mm round	8mm round	90	L-160	PGC-W6
	70	70	115	L-160	PGC-Y4
	70	25	90	L-160	PGC-Y4-Y1
	95	95	150	L-160	PGC-Y5
	120	120	200	L-160	PGC-Y6

KAYNAK ÇEŞİTLERİ

Supplement Shapes	Conductor Cross Section		Thermoweld Dimensions	Pliers Type	Code
	A (mm ²)	B (mm ²)			
HA 	25	-	45	M-129	HAA-Y1
	35	-	45	M-129	HAA-Y2
	50	-	45	M-129	HAA-Y3
	70	-	65	M-129	HAA-Y4
VG 	25	-	45	L-160	VGC-Y1
	35	-	45	L-160	VGC-Y2
	50	-	115	L-160	VGC-Y3
	8mm round	-	65	L-160	VGC-W6
	70	-	115	L-160	VGC-Y4
	95	-	150	L-160	VGC-Y5
	120	-	150	L-160	VGC-Y6
VS 	50	-	90	L-160	VSC-Y3
	70	-	90	L-160	VSC-Y4
	95	-	115	L-160	VSC-Y5
	120	-	115	L-160	VSC-Y6
BM 	2x30	2x30	65	L-160	BMP-BAK
	3x30	3x30	65	L-160	BMP-CAK
	3x40	3x40	90	L-160	BMC-CAL
EB 	2x30mm	2x30mm	90	L-161	EB-BGP-BAK
	2x25mm	2x25mm	65	L-161	EBP-CAJ
	3,5x25mm	3,5x25mm	65	L-161	G-EBP-DAJ
CC 	2x30mm	-	90	L-161	CCP-BAK
GR 	20mm	50mm ²	90	L-160	GRC-P20-Y3
	20mm	70mm ²	90	L-160	GRC-P20-Y4
	20mm	95mm ²	90	L-160	GRC-P20-Y5
	20mm	120mm ²	90	L-160	GRC-P20-Y6
	18mm	50mm ²	90	L-160	GRC-P18-Y3
	18mm		90	L-160	GRC-P18-Y4
	18mm	95mm ²	90	L-160	GRC-P18-Y5
	18mm	120mm ²	90	L-160	GRC-P18-Y6

KAYNAK ÇEŞİTLERİ

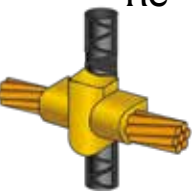
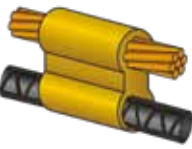
Supplement Shapes	Conductor Cross Section		Thermoweld Dimensions	Pliers Type	Code
	A (mm ²)	B (mm ²)			
 GT	20mm	50mm ²	90	L-160	GTC-P20-Y3
	20mm		90	L-160	GTC-P20-Y4
	20mm	95mm ²	115	L-160	GTC-P20-Y5
	20mm	120mm ²	150	L-160	GTC-P20-Y6
	18mm	50mm ²	90	L-160	GTC-P18-Y3
	18mm		90	L-160	GTC-P18-Y4
	18mm	95mm ²	115	L-160	GTC-P18-Y5
	18mm	120mm ²	150	L-160	GTC-P18-Y6
 RC	20-40mm	25	45	L-161A	RCP-Y1
	20-40mm	35	45	L-161A	RCP-Y2
	20-40mm	50	65	L-161A	RCP-Y3
	20-40mm	70	90	L-161A	RCP-Y4
	20-40mm	95	90	L-161A	RCP-Y5
	20-40mm	120	90	L-161A	RCP-Y6
 RT	20-40mm	25	45	SMK21	RTP-Y1
	20-40mm	35	45	SMK21	RTP-Y2
	20-40mm	50	90	SMK21	RTP-Y3
	20-40mm	70	90	SMK21	RTP-Y4
	20-40mm	95	90	SMK21	RTP-Y5
	20-40mm	120	115	SMK21	RTP-Y6

MAIN MATERIAL

A=Aluminium, B=Copper, D=Iron-Steel,
F=Bronze, G=Gray Cast Iron,
N=Stainless, P=Plastic, S=Brass

COATINGS

1=Electrogalvanizing, 2=Hot Dip Galvanizing, 3=Electrodeposited Copper,
4=Electrodeposited Tin, 5=Electrodeposited Chromium-Nickel,
6=Black Insulation, 7=Yellow-Green Insulation

SCREW NUT

DC=Galvanizing,
NC=Stainless,
SC=Brass

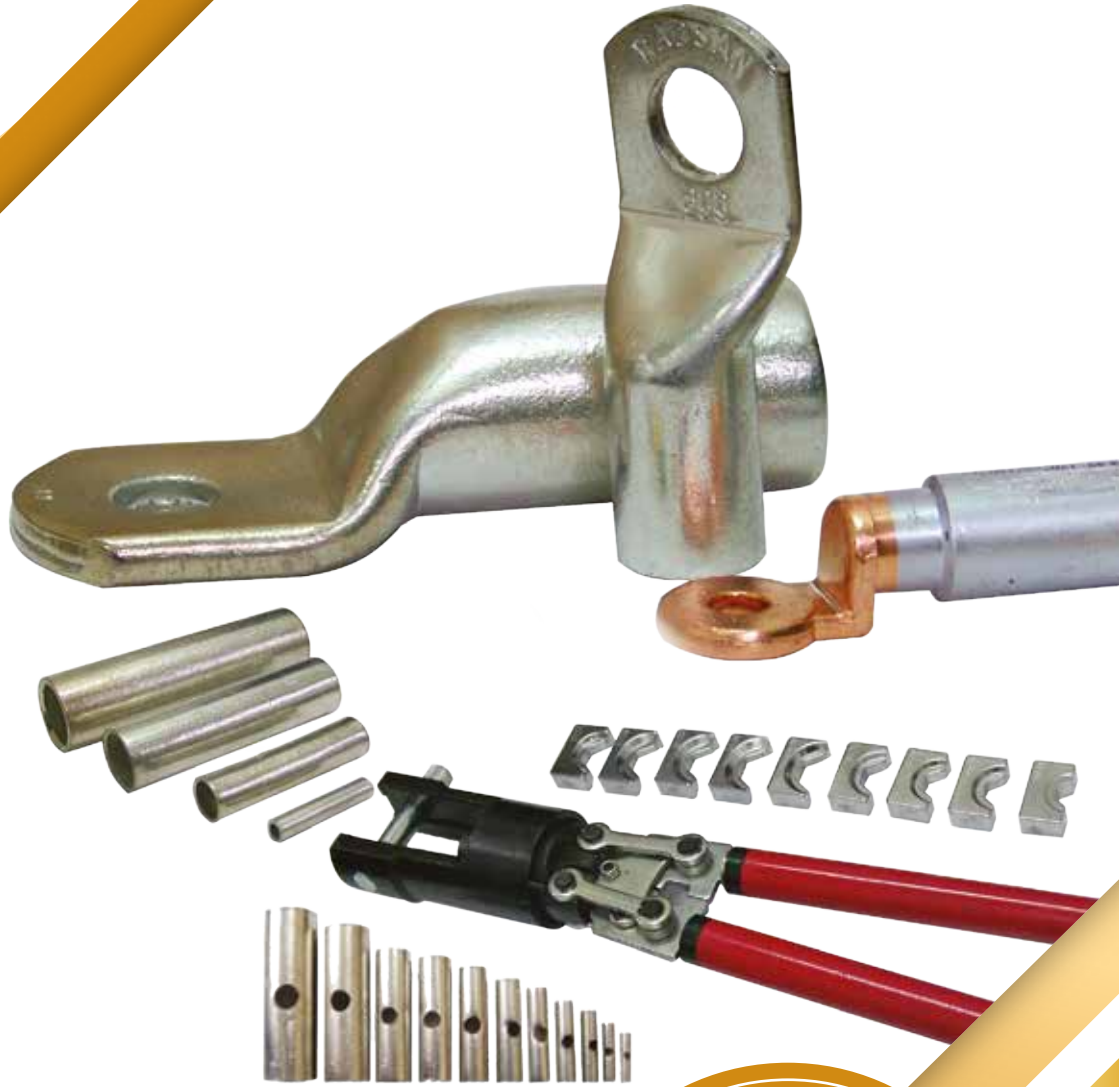

2021

CABLE ADDITIONAL ELEMENTS



For All Organizations

SECURE CONNECTION - SECURE SERVICE

High-Quality Raw Materials	High electrical conductivity and long corrosion resistance thanks to high-quality electrolytic copper and tin
Quality Production	Production is carried out with the highest precision and minimal error using CNC and automated production lines.
Quality Control	In our laboratory, our products are developed and supervised by constantly conducting electrical, mechanical and environmental tests.
On-Time Delivery	We ship your orders from our stock instantly. Therefore, the product is delivered as soon as possible and in the fastest way possible.
Complete Delivery	Thanks to the barcode system and automated packaging system we use in production, your orders are shipped with 100% accuracy.
Easy Assembly	Hassle-free cable installation thanks to the convenient countersink
Appropriate Hardness	Cable lugs that are soft enough to be easily shaped and hard enough not to loosen, thanks to advanced annealing technology.
Çeşitlilik	Solutions to all sectoral applications thanks to special productions, different hole diameters, wide product range.
Standards	Production in accordance with TSE, DIN standards

SKP CABLE LUGS

DIN 46235 Series

Features

- Cross-sectional Area: 6 - 630 mm²
- Electrolytic Copper
- Tin-plated
- Appropriate Hardness, Annealed Copper
- Proper branding

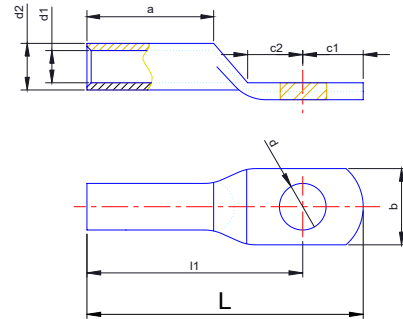

Product Code	Cable Cross Section mm ²	Bolt	Inner Diameter (d1)	Outer Diameter (d2)	Tail Length (L1)	Hole Length (a)	Title Width (b)	c1	c2	Total Height (L)	Box Quantity
TKD.103.01	6	M5	4,00	5,50	24,00	10,00	8,50	9,00	6,00	33,00	500
TKD.103.02	10	M6 M8	4,70	6,00	27,00	10,00	9,00	9,00 10,50	6,00 8,00	36,00 37,50	500
TKD.103.03	16	M6 M8 M10	5,70	8,50	36,00	20,00	13,00 13,00 17,00	10,50 13,00 15,00	8,00 10,00 12,00	46,50 49,00 51,00	250
TKD.103.04	25	M6 M8 M10 M12	7,20	10,00	38,00	20,00	14,00 16,00 17,00 19,00	10,50 13,00 15,00 16,00	8,00 10,00 12,00 13,00	48,50 51,00 53,00 54,00	200
TKD.103.05	35	M8 M10 M12	8,40	12,50	42,00	20,00	17,00 19,00 21,00	13,00 15,00 16,00	10,00 12,00 13,00	55,00 57,00 58,00	100
TKD.103.06	50	M8 M10 M12 M16	10,20	14,50	52,00	28,00	20,00 22,00 24,00 28,00	13,00 15,00 16,00 19,00	10,00 12,00 13,00 16,00	65,00 67,00 68,00 71,00	50
TKD.103.07	70	M8 M10 M12 M16	11,70	16,50	55,00	28,00	24,00 24,00 24,00 30,00	13,00 15,00 16,00 19,00	10,00 12,00 13,00 16,00	68,00 70,00 71,00 74,00	50
TKD.103.08	95	M10 M12 M16	13,70	19,00	65,00	35,00	28,00 28,00 32,00	15,00 16,00 19,00	12,00 13,00 16,00	80,00 81,00 84,00	40
TKD.103.09	120	M10 M12 M16 M20	15,70	21,00	70,00	35,00	32,00 32,00 32,00 38,00	15,00 16,00 19,00 22,00	12,00 13,00 16,00 20,00	85,00 86,00 89,00 92,00	30
TKD.103.10	150	M10 M12 M16 M20	17,20	23,50	78,00	35,00	34,00 34,00 34,00 40,00	15,00 16,00 19,00 22,00	12,00 13,00 16,00 20,00	93,00 94,00 97,00 100,00	20
TKD.103.11	185	M10 M12 M16 M20	19,20	25,50	82,00	40,00	37,00 37,00 37,00 40,00	15,00 16,00 19,00 22,00	12,00 13,00 16,00 20,00	97,00 101,00 104,00 108,00	20
TKD.103.12	240	M10 M16 M20	21,70	29,00	92,00	50,00	42,00 42,00 45,00	16,00 19,00 22,00	13,00 16,00 20,00	108,00 111,00 114,00	10
TKD.103.13	300	M16 M20	24,70	32,00	100,00	70,00	48,00	19,00 22,00	16,00 20,00	119,00 122,00	10
TKD.103.14	400	M16 M20	27,50	38,50	115,00	80,00	55,00	25,00 25,00	16,00 20,00	140,00 140,00	6
TKD.103.15	500	M20	31,20	42,00	125,00	100,00	60,00	25,00	20,00	150,00	4
TKD.103.16	625	M20	35,20	45,00	135,00	100,00	60,00	25,00	20,00	160,00	4

Part Number: TKD.103

SKP CABLE LUGS

Standard Series



Features

- Cross-sectional Area: 6 - 500 mm²
- Electrolytic Copper
- Tin-plated
- Appropriate Hardness, Annealed Copper
- **TS EN 61238-1 Certified**

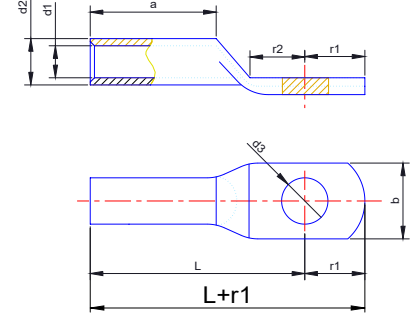

Part Number: TKR.103

Product Code	Cable Cross Section mm ²	Bolt	Delik Çapı (d3)	Inner Diameter (d1)	Outer Diameter (d2)	Hole Size (a)	Title Width (b)	Tail Length (L1)	r1	r2	Total Height (L)	Box Quantity
TKR.103.01	6	M5	5,50	4,00	5,50	7,50	12,00	24,00	8,00	8,00	32,00	500
TKR.103.02	10	M6	6,50	4,70	6,00	9,00	12,00	27,00	8,00	9,00	35,00	500
TKR.103.03	16	M8	8,50	6,20	8,00	11,50	13,00	29,00	9,00	9,00	38,00	250
TKR.103.04	25	M8	8,50	7,20	9,00	13,00	14,00	31,50	10,00	9,00	41,50	250
TKR.103.05	35	M10	10,50	8,20	11,00	15,50	21,50	40,00	10,00	9,75	50,00	150
TKR.103.06	50	M10	10,50	10,20	13,00	18,50	22,50	44,00	13,00	13,00	57,00	100
TKR.103.07	70	M12	12,50	12,20	15,00	21,50	25,00	49,00	10,00	14,50	59,00	75
TKR.103.08	95	M12	12,50	14,20	17,00	24,50	28,00	53,00	12,00	14,00	65,00	50
TKR.103.09	120	M14	14,50	15,20	19,00	27,00	26,00	59,00	13,00	13,50	72,00	40
TKR.103.10	150	M14	14,50	16,20	20,00	28,50	34,50	64,50	14,00	15,00	78,50	30
TKR.103.11	185	M16	16,50	19,20	23,00	33,50	36,00	72,00	18,00	19,00	90,00	20
TKR.103.12	240	M16	16,50	22,20	26,00	38,50	37,00	79,00	21,00	20,00	100,00	10
TKR.103.13	300	M20	22,00	24,20	29,00	42,50	40,00	85,00	20,00	20,50	105,00	10
TKR.103.14	400	M20	22,00	28,20	33,00	48,00	44,00	90,00	24,00	24,00	114,00	

SKP CABLE LUGS

Standard Series, Long Type

Features

- Cross-sectional Area: 6 - 500 mm²
- Electrolytic Copper
- Tin-plated
- Appropriate Hardness, Annealed Copper

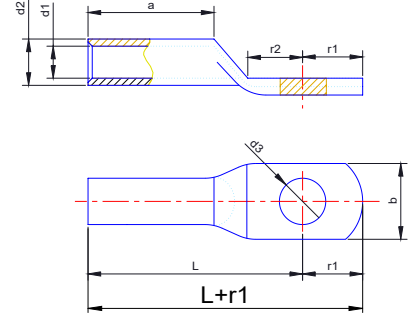

Part Number: TKRU.103

Product Code	Cable Cross Section (mm ²)	Bolt	Delik Çapı (d3)	Inner Diameter (d1)	Outer Diameter (d2)	Title Width (b)	Headline Size (a)	Tail Length (L1)	r1	r2	Total Height (L)	Box Quantity
TKRU.103.01	6	M5	5,50	4,00	5,50	7,50	17,00	24,00	8,00	8,00	37,00	500
TKRU.103.02	10	M6	6,50	4,70	6,00	9,00	17,00	27,00	8,00	9,00	40,00	500
TKRU.103.03	16	M8	8,50	6,20	8,00	11,50	16,00	29,00	9,00	9,00	41,00	250
TKRU.103.04	25	M8	8,50	7,20	9,00	13,00	21,50	31,50	10,00	9,00	49,00	250
TKRU.103.05	35	M10	10,50	8,20	11,00	15,50	26,50	40,00	10,00	10,00	55,00	150
TKRU.103.06	50	M10	10,50	10,20	13,00	18,50	25,50	44,00	13,00	13,00	60,00	100
TKRU.103.07	70	M12	12,50	12,20	15,00	21,50	36,00	49,00	10,00	14,50	70,00	75
TKRU.103.08	95	M12	12,50	14,20	17,00	24,50	39,00	53,00	12,00	14,00	76,00	50
TKRU.103.09	120	M14	14,50	15,20	19,00	27,00	39,00	59,00	13,00	13,50	85,00	40
TKRU.103.10	150	M14	14,50	16,20	20,00	28,50	44,00	64,50	14,00	15,00	88,00	30
TKRU.103.11	185	M16	16,50	19,20	23,00	33,50	41,00	72,00	18,00	19,00	95,00	20
TKRU.103.12	240	M16	16,50	22,20	26,00	38,50	41,00	79,00	21,00	20,00	104,00	10
TKRU.103.13	300	M20	22,00	24,20	29,00	42,50	48,00	85,00	20,00	20,50	113,00	10
TKRU.103.14	400	M20	22,00	28,20	33,00	48,00	52,00	90,00	24,00	24,00	120,00	6

SKP CABLE LUGS

Economic Series

Features

- Cross-sectional Area: 6 - 300 mm²
- Electrolytic Copper
- Kalay Kaplı
- Uygun Sertlik, Tavlanmış Bakır

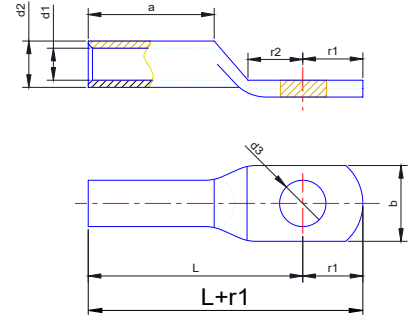

Part Number: TKPF.103

Product Code	Cable Cross Section (mm ²)	Bolt	Delik Çapı (d3)	Inner Diameter (d1)	Outer Diameter (d2)	Title Width (b)	Başlık Boyu (a)	Tail Length (L1)	r1	r2	Total Height (L+r1)	Box Quantity
TKPF.103.01	6	M4	5,50	4,00	5,50	7,50	13,00	24,00	8,00	8,50	32,00	500
TKPF.103.02	10	M4	6,50	4,70	6,00	9,00	12,50	27,00	7,50	8,25	34,50	500
TKPF.103.03	16	M6	8,50	5,70	7,00	10,00	15,00	29,50	9,00	9,00	38,50	250
TKPF.103.04	25	M8	8,50	7,20	8,50	12,50	14,00	31,50	10,00	10,50	41,50	250
TKPF.103.05	35	M10	10,50	8,20	10,00	14,50	18,00	38,00	12,00	12,00	50,00	150
TKPF.103.06	50	M10	10,50	10,20	12,00	17,50	26,00	47,00	10,00	10,00	57,00	100
TKPF.103.07	70	M12	12,50	11,70	14,00	20,50	24,00	48,50	10,50	13,50	59,00	75
TKPF.103.08	95	M12	12,50	13,70	16,00	23,50	27,00	52,75	12,25	12,50	65,00	50
TKPF.103.09	120	M14	14,50	15,50	18,00	26,50	28,00	57,50	13,50	14,00	71,00	40
TKPF.103.10	150	M14	14,50	17,20	20,00	29,50	36,00	65,00	14,00	15,00	79,00	30
TKPF.103.11	185	M16	16,50	18,70	22,00	32,00	36,00	72,00	18,00	18,00	90,00	20
TKPF.103.12	240	M16	16,50	20,70	24,50	36,50	40,00	80,00	20,00	20,50	100,00	10
TKPF.103.13	300	M20	22,00	23,20	28,00	42,00	40,00	83,00	22,00	23,00	105,00	
TKPF.103.14	400	M20	22,00	28,20	33,00	49,00	43,00	90,00	24,00	25,00	114,00	

SKP CABLE LUGS

Aluminum Series

Features

- Electrolytic Aluminum
- **TS EN 61238-1 Certified**

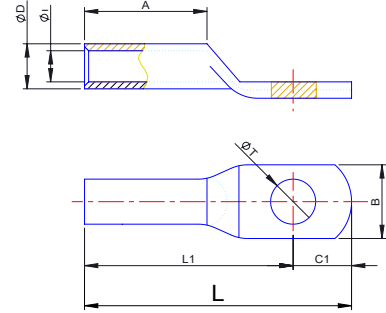

Product Code	Cable Cross Section (mm ²)	Bolt	Delik Çapı (ØT)	Inner Diameter (ØI)	Outer Diameter (ØD)	Title Width (B)	Başlık Boyu (A)	Tail Length (L1)	C1	Total Height (L)	Box Quantity
TKAD.103.03 A	16	M6	6,50	6,00	10,00	18,00	35,50	52,00	9,50	61,50	100
TKAD.103.04 A	25	M8	8,50	7,00	12,00	18,00	42,00	60,00	9,50	69,50	100
TKAD.103.05 A	35	M10	10,50	8,20	14,00	21,00	46,00	67,00	11,50	78,50	50
TKAD.103.06 A	50	M10	10,50	10,00	16,00	25,00	50,00	72,00	11,50	83,50	50
TKAD.103.07 A	70	M10	10,50	11,20	18,40	28,00	60,00	86,00	13,00	99,00	30
TKAD.103.08 A	95	M12	13,00	13,50	22,00	32,00	60,00	90,00	16,50	106,50	25
TKAD.103.09 A	120	M12	13,00	14,70	23,50	32,00	60,00	91,00	16,50	107,50	20
TKAD.103.10 A	150	M14	15,00	17,00	26,00	35,00	68,00	103,00	19,00	122,00	15
TKAD.103.11 A	185	M14	15,00	18,50	28,00	40,00	69,50	106,00	19,00	125,00	10
TKAD.103.12 A	240	M14	15,00	21,00	32,00	45,00	77,00	116,00	20,00	136,00	8
TKAD.103.13 A	300	M16	17,00	23,30	38,50	49,00	82,00	124,00	20,00	144,00	4

Aluminum Series

Features

- Electrolytic Aluminum
- **TS EN 61238-1 Certified**

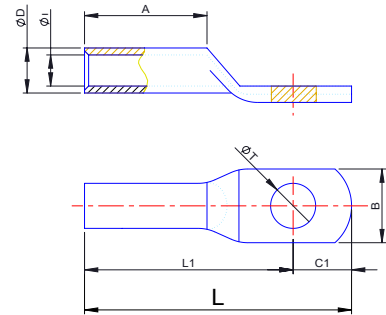

Product Code	Cable Cross-Section (mm ²)	Inner Diameter (D1)	Outer Diameter (D2)	Boy (L)	Box Quantity
TKAD.102.03 A	16	6	10	58	100
TKAD.102.04 A	25	7	12	64	100
TKAD.102.05 A	35	8,2	14	75	50
TKAD.102.06 A	50	10	16	82	50
TKAD.102.07 A	70	11,2	18,4	96	30
TKAD.102.08 A	95	13,5	22	104	25
TKAD.102.09 A	120	14,7	23,5	116	20
TKAD.102.10 A	150	17	26	122	15
TKAD.102.11 A	185	18,5	28	125	10
TKAD.102.12 A	240	21	32	136	8
TKAD.102.13 A	300	23,3	38,5	144	4

SKP CABLE LUGS

Bimetallic Series Standard Type



Features

- Cross-sectional Area 10 mm² – 630 mm²
- For aluminum cable-copper bus-bar connection
- It is manufactured using friction welding technology.
- High-quality and pure copper and aluminum
- Polished surface
- **TS EN 61238-1 Certified**

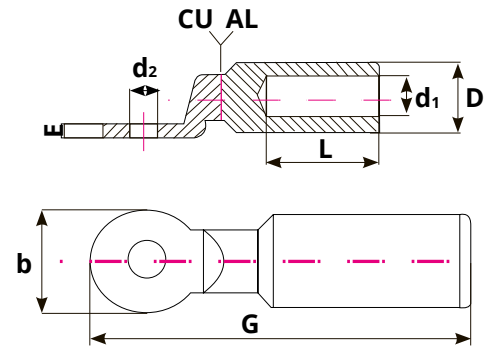

Product Code	Section (mm ²)	D ±0.2	d1 ±0.2	G±1	b±0.2	F±0.1	L±0.5
CAL-16BS	M8	16	6	82	24	3	41
CAL-25BS	M10	16	7	82	24	3	41
CAL-35BS	M10	16	8.5	82	24	3	41
CAL-50BS	M12	20	9.8	90	25	3.5	49
CAL-70BS	M12	20	11.6	90	25	3.5	49
CAL-95BS	M12	20	13.8	90	25	3.5	49
CAL-120BS	M12	25	15.5	113	28	4.2	60
CAL-150BS	M12	25	17	113	28	4.2	60
CAL-185BS	M12	32	18.5	130	35	5	62
CAL-240BS	M12	32	21.5	130	35	5	62
CAL-300BS	M12	34	24	135	36	5	63.5
CAL-400BS	M16	34	26	135	36	5	63.5

ADDITIONAL MUFFS

DIN Series

Product Code	Cable Cross-Section (mm ²)	Inner Diameter (D1)	Outer Diameter (D2)	Height (L)	Box Quantity
TKDE.102.01	6	4	5,5	30	500
TKDE.102.02	10	4,7	6	30	500
TKDE.102.03	16	5,7	8,5	50	250
TKDE.102.04	25	7,2	10	50	250
TKDE.102.05	35	8,4	12,5	50	150
TKDE.102.06	50	10,2	14,5	56	100
TKDE.102.07	70	11,7	16,5	56	75
TKDE.102.08	95	13,7	19	70	50
TKDE.102.09	120	15,7	21	70	40
TKDE.102.10	150	17,2	23,5	80	30
TKDE.102.11	185	19,2	25,5	90	20
TKDE.102.12	240	21,7	29	100	10
TKDE.102.13	300	24,7	32	120	
TKDE.102.14	400	27,5	38,5	150	
TKDE.102.15	500	31,2	42	160	
TKDE.102.16	625	35,2	45	160	



TSE Series

Product Code	Cable Cross-Section (mm ²)	Inner Diameter (D1)	Outer Diameter (D2)	Height (L)	Box Quantity
TKRE.102.01	6	4	5,5	25	500
TKRE.102.02	10	4,7	6	30	500
TKRE.102.03	16	6,2	8	35	250
TKRE.102.04	25	7,2	9	40	250
TKRE.102.05	35	8,2	11	45	150
TKRE.102.06	50	10,2	13	50	100
TKRE.102.07	70	12,2	15	55	75
TKRE.102.08	95	14,2	17	65	50
TKRE.102.09	120	15,2	19	70	40
TKRE.102.10	150	16,2	20	80	30
TKRE.102.11	185	19,2	23	85	20
TKRE.102.12	240	22,2	26	90	10
TKRE.102.13	300	24,2	29	104	



Economic Series

Product Code	Cable Cross-Section (mm ²)	Inner Diameter (D1)	Outer Diameter (D2)	Height (L)	Box Quantity
TKPE.102.01	6	4	5,5	25	500
TKPE.102.02	10	4,7	6	30	500
TKPE.102.03	16	6,2	8	35	250
TKPE.102.04	25	7,2	9	40	250
TKPE.102.05	35	8,2	11	45	150
TKPE.102.06	50	10,2	13	50	100
TKPE.102.07	70	12,2	15	55	75
TKPE.102.08	95	14,2	17	65	50
TKPE.102.09	120	15,2	19	70	40
TKPE.102.10	150	16,2	20	80	30
TKPE.102.11	185	19,2	23	85	20
TKPE.102.12	240	22,2	26	90	10
TKPE.102.13	300	24,2	29	104	



TIGHTENING METHOD



Safe Tightening

- ✓ Strip the cable to the required length according to the cable splice element.
- ✓ Make sure the cable and its connector are clean.
- ✓ Insert the cable fully into the splice element.
- ✓ Be sure to use the appropriate tightening tool.
- ✓ Squeeze from the innermost part to the outermost part.

TIGHTENING NUMBERS

Cross Section (mm ²)	SKP Cable Lugs		Cross Section (mm ²)	DIN 46235 Kablo Pabuçları		Cross Section (mm ²)	Alüminyum Kablo Pabuçları	
	Narrow Tightening Jaw	Wide Tightening Jaws		Narrow Tightening Jaw	Wide Tightening Jaws		Narrow Tightening Jaw	Wide Tightening Jaws
6	1		6	2		6		
10	1		10	2		10		
16	1	1	16	2	1	16	4	2
25	2	1	25	2	1	25	4	2
35	2	1	35	2	1	35	5	2
50	2	1	50	3	1	50	5	2
70	2	1	70	3	1	70	6	3
95	2	1	95	4	2	95	6	3
120	2	1	120	4	2	120	6	3
150	2	1	150	4	2	150	6	3
185	2	2	185	4	2	185	6	3
240	4	2	240	5	2	240	8	3
300	4	2	300		2	300	8	3
400	4	2	400		3	400		4
			500		3	500		4
			625		3			
			800		3			
			1000		3			